



**ASME B30.17-2015**

**(Consolidation of ASME B30.11 and B30.17)**

# **Cranes and Monorails (With Underhung Trolley or Bridge)**

**Safety Standard for Cableways,  
Cranes, Derricks, Hoists, Hooks,  
Jacks, and Slings**

**AN AMERICAN NATIONAL STANDARD**



**The American Society of  
Mechanical Engineers**



**ASME B30.17-2015**  
(Consolidation of ASME B30.11 and B30.17)

# **Cranes and Monorails (With Underhung Trolley or Bridge)**

---

**Safety Standard for Cableways,  
Cranes, Derricks, Hoists, Hooks,  
Jacks, and Slings**

**AN AMERICAN NATIONAL STANDARD**



**The American Society of  
Mechanical Engineers**

Two Park Avenue • New York, NY • 10016 USA



Date of Issuance: March 9, 2016

The next edition of this Standard is scheduled for publication in 2020. This Standard will become effective 1 year after the Date of Issuance.

ASME issues written replies to inquiries concerning interpretations of technical aspects of this Standard. Interpretations are published on the ASME Web site under the Committee Pages at <http://cstools.asme.org/> as they are issued. Interpretations will also be included with each edition.

Errata to codes and standards may be posted on the ASME Web site under the Committee Pages to provide corrections to incorrectly published items, or to correct typographical or grammatical errors in codes and standards. Such errata shall be used on the date posted.

The Committee Pages can be found at <http://cstools.asme.org/>. There is an option available to automatically receive an e-mail notification when errata are posted to a particular code or standard. This option can be found on the appropriate Committee Page after selecting “Errata” in the “Publication Information” section.

ASME is the registered trademark of The American Society of Mechanical Engineers.

This code or standard was developed under procedures accredited as meeting the criteria for American National Standards. The Standards Committee that approved the code or standard was balanced to assure that individuals from competent and concerned interests have had an opportunity to participate. The proposed code or standard was made available for public review and comment that provides an opportunity for additional public input from industry, academia, regulatory agencies, and the public-at-large.

ASME does not “approve,” “rate,” or “endorse” any item, construction, proprietary device, or activity.

ASME does not take any position with respect to the validity of any patent rights asserted in connection with any items mentioned in this document, and does not undertake to insure anyone utilizing a standard against liability for infringement of any applicable letters patent, nor assumes any such liability. Users of a code or standard are expressly advised that determination of the validity of any such patent rights, and the risk of infringement of such rights, is entirely their own responsibility.

Participation by federal agency representative(s) or person(s) affiliated with industry is not to be interpreted as government or industry endorsement of this code or standard.

ASME accepts responsibility for only those interpretations of this document issued in accordance with the established ASME procedures and policies, which precludes the issuance of interpretations by individuals.

No part of this document may be reproduced in any form,  
in an electronic retrieval system or otherwise,  
without the prior written permission of the publisher.

The American Society of Mechanical Engineers  
Two Park Avenue, New York, NY 10016-5990

Copyright © 2016 by  
THE AMERICAN SOCIETY OF MECHANICAL ENGINEERS  
All rights reserved  
Printed in U.S.A.

## CONTENTS

Foreword .....	v
Committee Roster .....	vii
B30 Standard Introduction .....	ix
Summary of Changes .....	xii
<b>Chapter 17-0 Scope, Definitions, References, and Personnel Competence .....</b>	<b>1</b>
Section 17-0.1 Scope of B30.17 .....	1
Section 17-0.2 Definitions .....	1
Section 17-0.3 References .....	4
Section 17-0.4 Personnel Competence .....	5
<b>Chapter 17-1 General Construction and Installation .....</b>	<b>15</b>
Section 17-1.1 Markings .....	15
Section 17-1.2 Clearances .....	15
Section 17-1.3 General Construction .....	16
Section 17-1.4 Track Switches, Track Openers, and Interlocks .....	17
Section 17-1.5 Vertical Drop or Lift Sections .....	17
Section 17-1.6 Cabs — Normal or Skeleton (If Provided) .....	17
Section 17-1.7 Lubrication .....	18
Section 17-1.8 Service Platforms (Footwalks) .....	18
Section 17-1.9 Stops and Bumpers .....	18
Section 17-1.10 Rail Sweeps .....	19
Section 17-1.11 Guards .....	20
Section 17-1.12 Drop Protection .....	20
Section 17-1.13 Brakes .....	20
Section 17-1.14 Electrical Equipment .....	21
Section 17-1.15 Hoisting Equipment .....	22
Section 17-1.16 Warning Devices .....	23
Section 17-1.17 Installation .....	23
Section 17-1.18 Trolleys (Carriers) .....	23
Section 17-1.19 Manual .....	23
<b>Chapter 17-2 Inspection and Testing .....</b>	<b>29</b>
Section 17-2.1 Inspection .....	29
Section 17-2.2 Testing .....	30
<b>Chapter 17-3 Operator Training and Operation .....</b>	<b>32</b>
Section 17-3.1 Operator Training .....	32
Section 17-3.2 Training for Persons Other Than Crane and Monorail System Operators .....	32
Section 17-3.3 Operation .....	32
Section 17-3.4 Planned Engineered Lifts .....	34
Section 17-3.5 Signals .....	35
Section 17-3.6 Miscellaneous .....	36
Section 17-3.7 Equipment Lockout/Tagout .....	36
<b>Chapter 17-4 Maintenance Training and Maintenance .....</b>	<b>38</b>
Section 17-4.1 Maintenance Training .....	38
Section 17-4.2 Equipment Maintenance .....	38
<b>Figures</b>	
17-0.2-1 Examples of Styles of Electrification .....	6
17-0.2-2 Cab-Operated Crane .....	7



17-0.2-3	Cantilever Gantry Crane .....	8
17-0.2-4	Floor-Operated Cranes .....	9
17-0.2-5	Gantry Crane .....	10
17-0.2-6	Wall-Supported Jib Crane .....	10
17-0.2-7	Portable Gantry Crane (A-Frame) .....	11
17-0.2-8	Semigantry Crane .....	11
17-0.2-9	Underhung Bridge Crane With Top Running Trolley .....	12
17-0.2-10	Drop Section (Lift Section) .....	12
17-0.2-11	Interlocking System for Underhung Crane .....	13
17-0.2-12	Example of One Type of Enclosed Track and Support Bracket .....	13
17-0.2-13	Cab-Operated Trolley .....	14
17-1.14.3-1	Recommended Arrangement of Controllers or Master Switches (Three-Motion Crane) .....	24
17-1.14.3-2	Recommended Arrangement of Controllers or Master Switches (Four-Motion Crane) .....	25
17-1.14.3-3	Recommended Arrangement of Controllers (Pendant Push-Button Station Arrangements) .....	26
17-1.14.3-4	Recommended Arrangement of Controllers (Radio Crane Control Transmitter Lever Arrangements) .....	26
17-1.18-1	Trolley Wheel Configurations .....	27
17-1.18-2	Recommended Trolley Fit .....	28
17-3.5.3-1	Standard Hand Signals for Cranes and Monorails .....	37

# آریا ایمن آوات



## FOREWORD

This American National Standard, Safety Standard for Cableways, Cranes, Derricks, Hoists, Hooks, Jacks, and Slings, has been developed under the procedures accredited by the American National Standards Institute (ANSI). This Standard had its beginning in December 1916 when an eight-page Code of Safety Standards for Cranes, prepared by an ASME Committee on the Protection of Industrial Workers, was presented at the annual meeting of the ASME.

Meetings and discussions regarding safety on cranes, derricks, and hoists were held from 1920 to 1925, involving the ASME Safety Code Correlating Committee, the Association of Iron and Steel Electrical Engineers, the American Museum of Safety, the American Engineering Standards Committee (AESC) [later changed to American Standards Association (ASA), then to the United States of America Standards Institute (USASI), and finally to ANSI], Department of Labor – State of New Jersey, Department of Labor and Industry – State of Pennsylvania, and the Locomotive Crane Manufacturers Association. On June 11, 1925, AESC approved the ASME Safety Code Correlating Committee's recommendation and authorized the project with the U.S. Department of the Navy, Bureau of Yards and Docks, and ASME as sponsors.

In March 1926, invitations were issued to 50 organizations to appoint representatives to a Sectional Committee. The call for organization of this Sectional Committee was sent out on October 2, 1926, and the Committee was organized on November 4, 1926, with 57 members representing 29 national organizations. Commencing June 1, 1927, and using the eight-page code published by ASME in 1916 as a basis, the Sectional Committee developed the Safety Code for Cranes, Derricks, and Hoists. The early drafts of this safety code included requirements for jacks, but due to inputs and comments on those drafts, the Sectional Committee decided in 1938 to make the requirements for jacks a separate code. In January 1943, ASA B30.2-1943 was published, addressing a multitude of equipment types, and in August 1943, ASA B30.1-1943 was published, addressing just jacks. Both documents were reaffirmed in 1952 and widely accepted as safety standards.

Due to changes in design, advancement in techniques, and general interest of labor and industry in safety, the Sectional Committee, under the joint sponsorship of ASME and the Bureau of Yards and Docks (now the Naval Facilities Engineering Command), was reorganized on January 31, 1962, with 39 members representing 27 national organizations. The new committee changed the format of ASA B30.2-1943 so that the multitude of equipment types it addressed could be published in separate volumes that could completely cover the construction, installation, inspection, testing, maintenance, and operation of each type of equipment that was included in the scope of ASA B30.2. This format change resulted in the initial publication of B30.3, B30.5, B30.6, B30.11, and B30.16 being designated as Revisions of B30.2 with the remainder of the B30 Volumes being published as totally new volumes. ASA changed its name to USASI in 1966 and to ANSI in 1969, which resulted in B30 Volumes from 1943 to 1968 being designated as either ASA B30, USAS B30, or ANSI B30 depending on their date of publication.

In 1982, the Committee was reorganized as an Accredited Organization Committee, operating under procedures developed by ASME and accredited by ANSI. This Standard presents a coordinated set of rules that may serve as a guide to government and other regulatory bodies and municipal authorities responsible for the guarding and inspection of the equipment falling within its scope. The suggestions leading to accident prevention are given both as mandatory and advisory provisions; compliance with both types may be required by employers of their employees.

In case of practical difficulties, new developments, or unnecessary hardship, the administrative or regulatory authority may grant variances from the literal requirements or permit the use of other devices or methods, but only when it is clearly evident that an equivalent degree of protection is thereby secured. To secure uniform application and interpretation of this Standard, administrative or regulatory authorities are urged to consult the B30 Committee, in accordance with the format described in the introduction of Section IX, before rendering decisions on disputed points.



Safety codes and standards are intended to enhance public safety. Revisions result from commitment and consideration of factors such as technological advances, new data, and changing environmental and industry needs. Revisions do not imply that previous editions were inadequate.

This Edition of B30.17 consolidates the requirements of B30.17-2006 (R2012) and B30.11-2010. The Volume has been completely revised to incorporate these revisions.

This Volume of the Standard, which was approved by the B30 Committee and by ASME, was approved by ANSI and designated as an American National Standard on December 4, 2015.

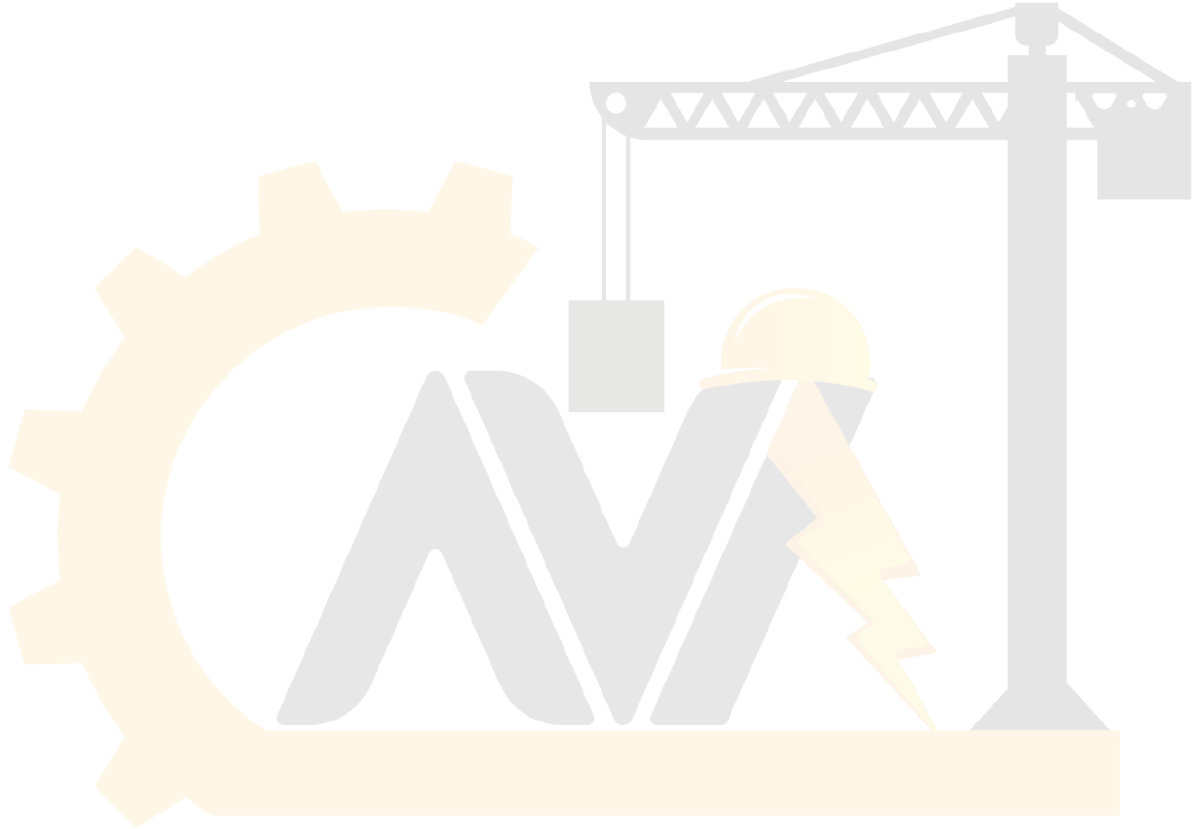

# آریا ایمن آوات



# ASME B30 COMMITTEE

## Safety Standard for Cableways, Cranes, Derricks, Hoists, Hooks, Jacks, and Slings

(The following is the roster of the Committee at the time of approval of this Standard.)

### STANDARDS COMMITTEE OFFICERS

**B. D. Closson**, *Chair*  
**T. L. Blanton**, *Vice Chair*  
**K. M. Hyam**, *Secretary*

### STANDARDS COMMITTEE PERSONNEL

**N. E. Andrew**, LTS Cranes Mechanical  
**M. Eggenberger**, *Alternate*, Berry Contracting, Inc.  
**G. Austin**, Terex Corp.  
**T. L. Blanton**, NACB Group, Inc.  
**P. A. Boeckman**, The Crosby Group  
**E. E. Lutter**, *Alternate*, The Crosby Group  
**P. W. Boyd**, The Boeing Co.  
**M. E. Brunet**, The Manitowoc Co.  
**A. L. Calta**, *Alternate*, The Manitowoc Co.  
**B. D. Closson**, Craft Forensic Services  
**J. A. Danielson**, The Boeing Co.  
**B. M. Casey**, *Alternate*, General Dynamics Electric Boat  
**D. Decker**, Becket, LLC  
**L. D. DeMark**, Equipment Training Solutions, LLC  
**D. F. Jordan**, *Alternate*, BP America  
**D. W. Eckstine**, Eckstine & Associates  
**G. J. Brent**, *Alternate*, NCCCO  
**R. J. Edwards**, NBIS Claims and Risk Management, Inc.  
**A. J. Egging**, National Oilwell Varco  
**R. Stanoch**, *Alternate*, National Oilwell Varco  
**E. D. Fidler**, The Manitowoc Co.  
**G. D. Miller**, *Alternate*, The Manitowoc Co.  
**J. A. Gilbert**, Associated Wire Rope Fabricators  
**J. L. Gordon**, Acco Chain & Lifting Products  
**N. C. Hargreaves**, Hargreaves Consulting, LLC  
**G. B. Hetherston**, Consultant  
**R. J. Bolen**, *Alternate*, E. I. DuPont  
**K. M. Hyam**, The American Society of Mechanical Engineers  
**M. M. Jaxtheimer**, Navy Crane Center  
**S. R. Gridley**, *Alternate*, Navy Crane Center  
**P. R. Juhren**, Morrow Equipment Co., LLC  
**M. J. Quinn**, *Alternate*, Morrow Equipment Co., LLC  
**R. M. Kohner**, Landmark Engineering Services, Ltd.  
**D. Duerr**, *Alternate*, 2DM Associates, Inc.  
**A. J. Lusi, Jr.**, Lumark Consulting, LLP  
**K. J. Shinn**, *Alternate*, K. J. Shinn, Inc.  
**E. K. Marburg**, Columbus McKinnon Corp.  
**J. R. Burkey**, *Alternate*, Columbus McKinnon Corp.  
**L. D. Means**, Means Engineering & Consulting  
**D. A. Henninger**, *Alternate*, Bridon American  
**M. W. Mills**, Liberty Mutual Insurance  
**D. M. Gordon**, *Alternate*, Liberty Mutual Insurance  
**D. L. Morgan**, Critical Lift Consultants, LLC  
**T. C. Mackey**, *Alternate*, WRPS Hanford  
**W. E. Osborn**, Ingersoll Rand  
**S. D. Wood**, *Alternate*, Link-Belt Construction Equipment Co.  
**R. M. Parnell**, Industrial Training International  
**W. C. Dickinson, Jr.**, *Alternate*, Industrial Training International  
**J. T. Perkins**, Solarex  
**J. R. Schober**, *Alternate*, American Bridge Co.  
**B. A. Pickett**, Systems Engineering and Forensic Services  
**S. K. Rammelsberg**, Chicago Bridge & Iron Co.  
**J. E. Richardson**, Navy Crane Center  
**K. Kennedy**, *Alternate*, Navy Crane Center  
**D. W. Ritchie**, David Ritchie Consultant, LLC  
**L. K. Shapiro**, *Alternate*, Howard I. Shapiro & Associates  
**J. W. Rowland III**, Consultant  
**D. A. Moore**, *Alternate*, Unified Engineering  
**J. C. Ryan**, Boh Bros. Construction Co., LLC  
**A. R. Ruud**, *Alternate*, Atkinson Construction  
**D. W. Smith**, STI Group  
**W. J. Smith, Jr.**, NBIS Claims and Risk Management, Inc.  
**J. Schoppert**, *Alternate*, NBIS Claims and Risk Management, Inc.  
**R. S. Stemp**, Lampson International, LLC  
**E. P. Vliet**, *Alternate*, Turner Industries Group  
**R. G. Strain**, Advanced Crane Technologies, LLC  
**J. Sturm**, Sturm Corp.  
**P. D. Sweeney**, General Dynamics Electric Boat  
**J. D. Wiethorn**, Haag Engineering Co.  
**M. Gardiner**, *Alternate*, Haag Engineering Co.  
**R. C. Wild**, CJ Drilling, Inc.  
**J. Dudley**, *Alternate*, Archer Western Contractors  
**D. N. Wolff**, National Crane/Manitowoc Crane Group  
**J. A. Pilgrim**, *Alternate*, Manitowoc Crane Group





## HONORARY MEMBERS

**J. W. Downs, Jr.**, Downs Crane and Hoist Co.  
**J. L. Franks**, Consultant  
**C. W. Ireland**, National Oilwell Varco  
**J. M. Klibert**, Lift-All Co., Inc.  
**R. W. Parry**, Consultant  
**P. S. Zorich**, Consultant

## B30.17 SUBCOMMITTEE PERSONNEL

**R. M. Cutshall**, *Chair*, Savannah River Nuclear Solutions, LLC  
**G. B. Hetherston**, *Chair*, Consultant  
**C. E. Cotton**, Navy Crane Center  
**J. L. Gordon**, Acco Chain & Lifting Products  
**J. B. Greenwood**, Navy Crane Center  
**H. G. Leidich**, Leidich Consulting Services, Inc.

**P. Lussier**, Granite Edge Safety Training & Services  
**L. D. Means**, *Contributing Member*, Means Engineering & Consulting  
**B. A. Pickett**, System Engineering and Forensic Services  
**D. Stevens**, InTomes, LLC

## B30 INTEREST REVIEW GROUP

**O. Akinboboye**, Ropetech Engineering Services  
**J. D. Cannon**, Consultant  
**M. Eggenberger**, Berry Contracting, Inc.  
**A. Gomes Rocha**, Belgo Bekaert Arames  
**H. A. Hashem**, Saudi Aramco  
**J. Hui**, School of Civil Engineering, People's Republic of China

**A. C. Mattoli**, Prowinch, LLC  
**M. W. Osborne**, E-Crane International USA  
**G. L. Owens**, Consultant  
**W. Rumburg**, Crane Consultants, Inc.  
**C.-C. Tsauro**, Institute of Occupational Safety and Health, Taiwan

## B30 REGULATORY AUTHORITY COUNCIL

**C. Shelhamer**, *Chair*, New York City Department of Buildings  
**A. O. Omran**, *Alternate*, New York City Department of Buildings  
**K. M. Hyam**, *Secretary*, The American Society of Mechanical Engineers  
**G. Beer**, Iowa OSHA  
**L. G. Champion**, U.S. Department of Labor/OSHA  
**W. L. Cooper**, Arizona Division of Occupational Safety and Health  
**R. Feidt**, Stephenson Equipment, Inc.

**C. Harris**, City of Chicago – Department of Buildings  
**J. L. Lankford**, State of Nevada/OSHA  
**A. Lundeen**, State of Washington – Department of Labor and Industries  
**G. E. Pushies**, MIOSHA  
**C. N. Stribling, Jr.**, Kentucky Labor Cabinet  
**T. Taylor**, State of Minnesota – Department of Labor and Industry  
**C. Tolson**, State of California – OSH Standards Board

آریا ایمن آوات



# SAFETY STANDARD FOR CABLEWAYS, CRANES, DERRICKS, HOISTS, HOOKS, JACKS, AND SLINGS

## B30 STANDARD INTRODUCTION

(15)

### SECTION I: SCOPE

The ASME B30 Standard contains provisions that apply to the construction, installation, operation, inspection, testing, maintenance, and use of cranes and other lifting and material-movement related equipment. For the convenience of the reader, the Standard has been divided into separate volumes. Each volume has been written under the direction of the ASME B30 Standard Committee and has successfully completed a consensus approval process under the general auspices of the American National Standards Institute (ANSI).

As of the date of issuance of this Volume, the B30 Standard comprises the following volumes:

- B30.1 Jacks, Industrial Rollers, Air Casters, and Hydraulic Gantries
- B30.2 Overhead and Gantry Cranes (Top Running Bridge, Single or Multiple Girder, Top Running Trolley Hoist)
- B30.3 Tower Cranes
- B30.4 Portal and Pedestal Cranes
- B30.5 Mobile and Locomotive Cranes
- B30.6 Derricks
- B30.7 Winches
- B30.8 Floating Cranes and Floating Derricks
- B30.9 Slings
- B30.10 Hooks
- B30.11 Monorails and Underhung Cranes<sup>1</sup>
- B30.12 Handling Loads Suspended From Rotorcraft
- B30.13 Storage/Retrieval (S/R) Machines and Associated Equipment
- B30.14 Side Boom Tractors
- B30.15 Mobile Hydraulic Cranes  
(withdrawn 1982 — requirements found in latest revision of B30.5)
- B30.16 Overhead Hoists (Underhung)
- B30.17 Cranes and Monorails (With Underhung Trolley or Bridge)
- B30.18 Stacker Cranes (Top or Under Running Bridge, Multiple Girder With Top or Under Running Trolley Hoist)
- B30.19 Cableways
- B30.20 Below-the-Hook Lifting Devices

- B30.21 Lever Hoists
- B30.22 Articulating Boom Cranes
- B30.23 Personnel Lifting Systems
- B30.24 Container Cranes
- B30.25 Scrap and Material Handlers
- B30.26 Rigging Hardware
- B30.27 Material Placement Systems
- B30.28 Balance Lifting Units
- B30.29 Self-Erecting Tower Cranes
- B30.30 Ropes<sup>2</sup>

### SECTION II: SCOPE EXCLUSIONS

Any exclusion of, or limitations applicable to the equipment, requirements, recommendations, or operations contained in this Standard are established in the affected volume's scope.

### SECTION III: PURPOSE

The B30 Standard is intended to

- (a) prevent or minimize injury to workers, and otherwise provide for the protection of life, limb, and property by prescribing safety requirements
- (b) provide direction to manufacturers, owners, employers, users, and others concerned with, or responsible for, its application
- (c) guide governments and other regulatory bodies in the development, promulgation, and enforcement of appropriate safety directives

### SECTION IV: USE BY REGULATORY AGENCIES

These volumes may be adopted in whole or in part for governmental or regulatory use. If adopted for governmental use, the references to other national codes and standards in the specific volumes may be changed to refer to the corresponding regulations of the governmental authorities.

### SECTION V: EFFECTIVE DATE

(a) *Effective Date.* The effective date of this Volume of the B30 Standard shall be 1 yr after its date of issuance.

<sup>1</sup> This Volume is consolidated into B30.17 and will be withdrawn.

<sup>2</sup> This Volume is currently in the development process.



, installation, inspection, testing, maintenance, operation of equipment manufactured and constructed after the effective date of this Volume shall conform to the mandatory requirements of this Volume.

(b) *Existing Installations.* Equipment manufactured and facilities constructed prior to the effective date of this Volume of the B30 Standard shall be subject to the inspection, testing, maintenance, and operation requirements of this Standard after the effective date.

It is not the intent of this Volume of the B30 Standard to require retrofitting of existing equipment. However, when an item is being modified, its performance requirements shall be reviewed relative to the requirements within the current volume. The need to meet the current requirements shall be evaluated by a qualified person selected by the owner (user). Recommended changes shall be made by the owner (user) within 1 yr.

## SECTION VI: REQUIREMENTS AND RECOMMENDATIONS

Requirements of this Standard are characterized by use of the word *shall*. Recommendations of this Standard are characterized by the word *should*.

## SECTION VII: USE OF MEASUREMENT UNITS

This Standard contains SI (metric) units as well as U.S. Customary units. The values stated in U.S. Customary units are to be regarded as the standard. The SI units are a direct (soft) conversion from the U.S. Customary units.

## SECTION VIII: REQUESTS FOR REVISION

The B30 Standard Committee will consider requests for revision of any of the volumes within the B30 Standard. Such requests should be directed to

Secretary, B30 Standard Committee  
ASME Codes and Standards  
Two Park Avenue  
New York, NY 10016-5990

Requests should be in the following format:

- Volume: Cite the designation and title of the volume.
- Edition: Cite the applicable edition of the volume.
- Subject: Cite the applicable paragraph number(s) and the relevant heading(s).
- Request: Indicate the suggested revision.
- Rationale: State the rationale for the suggested revision.

Upon receipt by the Secretary, the request will be forwarded to the relevant B30 Subcommittee for consideration and action. Correspondence will be provided to

the requester defining the actions undertaken by the B30 Standard Committee.

## SECTION IX: REQUESTS FOR INTERPRETATION

The B30 Standard Committee will render an interpretation of the provisions of the B30 Standard. Such requests should be directed to

Secretary, B30 Standard Committee  
ASME Codes and Standards  
Two Park Avenue  
New York, NY 10016-5990

Requests should be in the following format:

- Volume: Cite the designation and title of the volume.
- Edition: Cite the applicable edition of the volume.
- Subject: Cite the applicable paragraph number(s) and the relevant heading(s).
- Question: Phrase the question as a request for an interpretation of a specific provision suitable for general understanding and use, not as a request for approval of a proprietary design or situation. Plans or drawings that explain the question may be submitted to clarify the question. However, they should not contain any proprietary names or information.

Upon receipt by the Secretary, the request will be forwarded to the relevant B30 Subcommittee for a draft response, which will then be subject to approval by the B30 Standard Committee prior to its formal issuance.

Interpretations to the B30 Standard will be published in the subsequent edition of the respective volume, and will be available online at <http://cstools.asme.org/>.

## SECTION X: ADDITIONAL GUIDANCE

The equipment covered by the B30 Standard is subject to hazards that cannot be abated by mechanical means, but only by the exercise of intelligence, care, and common sense. It is therefore essential to have personnel involved in the use and operation of equipment who are competent, careful, physically and mentally qualified, and trained in the proper operation of the equipment and the handling of loads. Serious hazards include, but are not limited to, improper or inadequate maintenance, overloading, dropping or slipping of the load, obstructing the free passage of the load, and using equipment for a purpose for which it was not intended or designed.

The B30 Standard Committee fully realizes the importance of proper design factors, minimum or maximum dimensions, and other limiting criteria of wire rope or chain and their fastenings, sheaves, sprockets, drums, and similar equipment covered by the standard, all of



These factors are closely connected with safety. Sizes, strengths, and similar criteria are dependent on many different factors, often varying with the installation and uses.

These factors depend on

- (a) the condition of the equipment or material
- (b) the loads
- (c) the acceleration or speed of the ropes, chains, sheaves, sprockets, or drums
- (d) the type of attachments

(e) the number, size, and arrangement of sheaves or other parts

(f) environmental conditions causing corrosion or wear

(g) many variables that must be considered in each individual case

The requirements and recommendations provided in the volumes must be interpreted accordingly, and judgment used in determining their application.

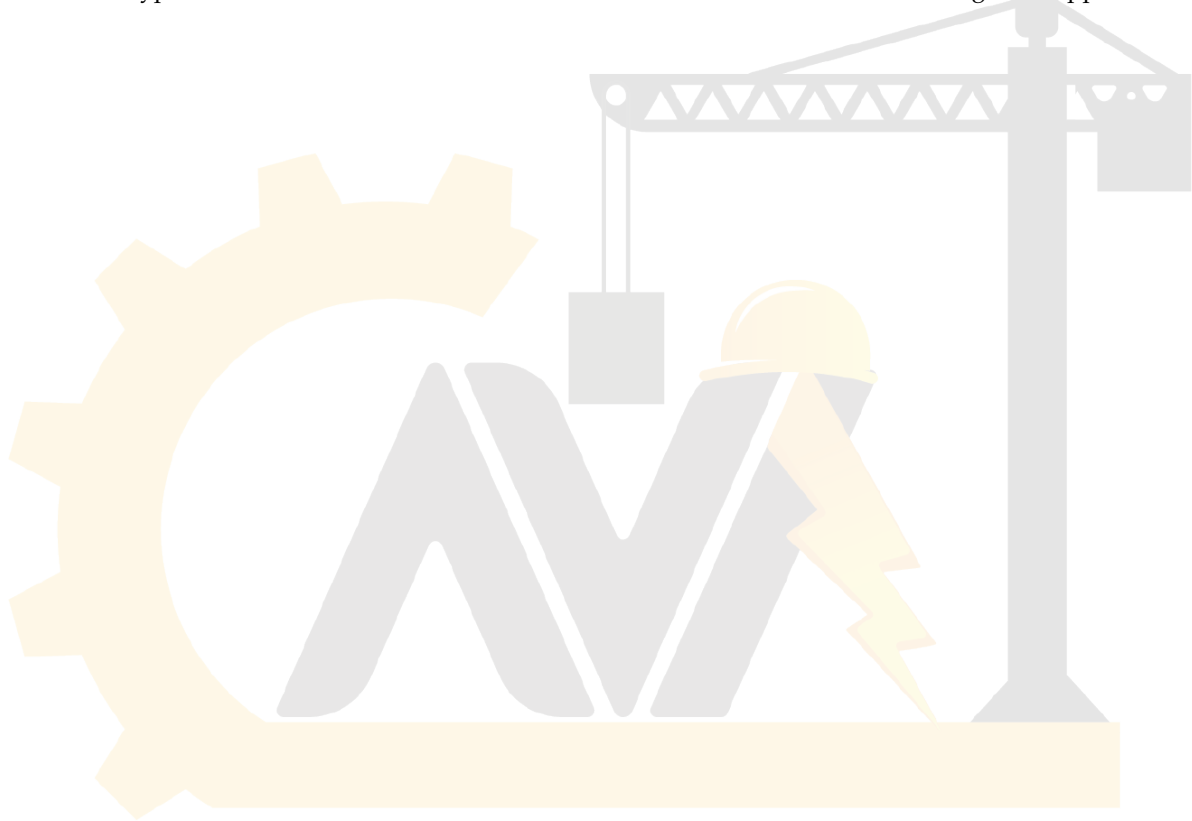

# آریا ایمن آوات

## ASME B30.17-2015 SUMMARY OF CHANGES

Following approval by the ASME B30 Committee and ASME, and after public review, ASME B30.17-2015 was approved by the American National Standards Institute on December 4, 2015.

ASME B30.17-2015, retitled “Cranes and Monorails (With Underhung Trolley or Bridge),” includes revisions throughout for consolidation with the requirements of B30.11. These revisions are identified by a margin note, (15).

<i>Page</i>	<i>Location</i>	<i>Change</i>
ix–xi	B30 Standard Introduction	Updated
1–14	Chapter 17-0	Revised in its entirety
15–28	Chapter 17-1	Revised in its entirety
29–31	Chapter 17-2	Revised in its entirety
32–37	Chapter 17-3	Revised in its entirety
38–40	Chapter 17-4	Added

### **SPECIAL NOTE:**

The interpretations to ASME B30.17 are included in this Edition as a separate section for the user’s convenience.



# CRANES AND MONORAILS (WITH UNDERHUNG TROLLEY OR BRIDGE)

## Chapter 17-0

(15)

### Scope, Definitions, References, and Personnel Competence

#### SECTION 17-0.1: SCOPE OF B30.17

Volume B30.17 includes provisions that apply to the construction, installation, operation, inspection, testing, and maintenance of hand-operated and power-operated overhead cranes and monorail systems with an underhung trolley and/or bridge. These cranes and monorail systems shall support one or more hoists used for vertical lifting and lowering of freely suspended, unguided loads, and include top running and underhung bridge cranes, gantry cranes, traveling wall cranes, jib cranes, polar gantry cranes, portable gantries, other cranes having the same fundamental characteristics, and monorail systems including trolleys (carriers) and end trucks. Track sections and their support systems for monorail systems, runways and their support systems for underhung cranes, and runway rails for top running cranes are also within the scope of this Volume.

Provisions for similar equipment used for a special purpose, such as, but not limited to, nonvertical lifting service, lifting a guided load, or lifting personnel, are not included in this Volume.

#### SECTION 17-0.2: DEFINITIONS

*abnormal operating conditions*: environmental conditions that are unfavorable, harmful, or detrimental to or for the operation of the crane or trolley, such as excessively high or low ambient temperatures, exposure to weather, corrosive fumes, dust- or moisture-laden atmospheres, and hazardous locations.

*below-the-hook lifting device*: a device used for attaching loads to a hoist. The device may contain components such as slings, hooks, and rigging hardware addressed by other ASME B30 Volumes or other standards.

*brake*: a device, other than a motor, used for retarding or stopping motion by friction or power means.

*braking, hydraulic*: a method of controlling or reducing speed by means of displacement of a liquid.

*braking means*: a method or device used for stopping/holding motion by friction or power.

*braking, mechanical*: a method of controlling or reducing speed by friction.

*braking, pneumatic*: a method of controlling or powering a brake by means of compressed gas.

*bridge*: the part of an overhead crane consisting of one or more girders, trucks, and (if applicable) a drive mechanism that carries the trolley(s).

*bridge girder*: a crane member on which a trolley or trolleys travel horizontally, mounted between and supported by the end trucks.

*bridge travel*: the crane movement in a direction parallel to the crane runway.

*bumper (buffer)*: a device for reducing impact when a moving crane or trolley reaches the end of its permitted travel, or when two moving cranes or trolleys come into contact. This device may be attached to the bridge, trolley, or runway stop.

*cab*: an operator's compartment attached to a crane or trolley.

*cab, normal*: an operator's compartment used for controlling a cab-operated crane or trolley.

*cab, skeleton*: an operator's compartment used for occasional cab operation of, normally, a floor- or remote-operated crane or trolley.

*carrier*: (also known as *trolley*) a unit that travels on the bottom flange of a monorail track, jib boom, or bridge girder to transport a load.

*chain, load*: the load-bearing chain in a hoist.

*clamp, hanger*: a type of suspension fitting used to support tracks from an overhead structure which is fastened to the structure by mechanical means rather than by welding or direct bolting.

*clearance*: the distance from any part of the crane to the nearest obstruction.

*collectors, current*: contacting devices for conducting current from runway or bridge conductors.



**bridge:** the electrical conductors located along the structure of a crane that transmit control signals and power to the trolley(s).

**conductors (electrification):** the system by which the moving equipment receives its electrical power (see Fig. 17-0.2-1).

**conductors, runway (main):** the electrical conductors located along a crane runway that transmit control signals and power to the crane.

**controller:** a device by means of which the operator controls the speed, acceleration, torque, and/or direction of motor-driven equipment.

**controller, manual:** a controller having all of its basic functions performed by devices that are operated by hand.

**controller, spring-return:** a controller that, when released, will return automatically to a neutral (OFF) position.

**crane:** a machine for lifting and lowering a load and moving it horizontally with the hoisting mechanism being an integral part of the machine.

**crane, automatic:** a crane that, when activated, operates through a preset cycle or cycles.

**crane, cab-operated:** a crane controlled by an operator in a cab attached to the crane or trolley (see Fig. 17-0.2-2).

**crane, cantilever gantry:** a gantry or semigantry crane in which the bridge girder(s) or truss(es) extend transversely beyond the crane runway on one or both sides (see Fig. 17-0.2-3).

**crane, double-girder:** a crane having two bridge girders mounted between, and supported from, the end trucks.

**crane, floor-operated:** a crane that is controlled by a means suspended from the crane or trolley, or from a wall-mounted station and operated by an operator on the floor or on an independent platform (see Fig. 17-0.2-4).

**crane, gantry:** a crane similar to an overhead crane, except that the bridge for carrying the trolley(s) is rigidly supported on two or more legs running on fixed rails or other runway (see Fig. 17-0.2-5).

**crane, hot molten material-handling:** an overhead crane used for transporting or pouring molten material.

**crane, interlocking:** a crane with an interlock mechanism on one or both ends, enabling it to be mechanically locked to another crane, fixed transfer section, or spur track for the purpose of transferring a trolley from one to another.

**crane, jib:** a fixed crane, usually mounted on a wall or building column, consisting of a rotating horizontal boom (either cantilevered or supported by tie rods) carrying a trolley or hoist (see Fig. 17-0.2-6).

**crane, manually operated:** a crane whose travel mechanism is driven by pulling an endless chain, or by manually moving the load.

**crane operator, dedicated:** an employee whose job is confined solely to the operation of an overhead or gantry crane.

**crane operator, nondedicated:** an employee who uses an overhead or gantry crane as a tool to assist in the performance of his/her regular job.

**crane, outdoor:** an overhead or gantry crane that operates outdoors and for which provisions are not available for storage in an area that provides protection to the crane from weather conditions.

**NOTE:** An indoor crane that may operate outdoors on a periodic basis is not classified as an outdoor crane.

**crane, overhead:** a crane with a movable bridge carrying a movable or fixed hoisting mechanism and traveling on an overhead, fixed runway structure (see Figs. 17-0.2-2, 17-0.2-4, and 17-0.2-9 for the types covered by this Volume).

**crane, pedestal (pillar-jib):** a fixed crane consisting of a rotating vertical member with a horizontal arm carrying a trolley and hoist.

**crane, polar:** an overhead or gantry crane that travels on a circular runway.

**crane, portable gantry (A-frame):** a crane similar to an overhead crane, except that the bridge for carrying the trolley(s) is rigidly supported on two or more legs supported by casters (see Fig. 17-0.2-7).

**crane, power-operated:** a crane whose mechanism is driven by electric, pneumatic, hydraulic, or internal combustion means.

**crane, pulpit-operated:** a crane operated from a fixed operator station not attached to the crane.

**crane, remote-operated:** a crane controlled by an operator not in a pulpit nor in the cab attached to the crane, and controlled by any method other than a means suspended from the crane.

**crane, semigantry:** a crane with one end of the bridge rigidly supported on one or more legs that run on a fixed rail, and the other end of the bridge supported by an end truck suspended from an elevated track (see Fig. 17-0.2-8).

**crane, single-girder:** a crane having one bridge girder mounted between, and supported from, the end trucks.

**crane, underhung:** a crane with a single- or multiple-girder movable bridge carrying a movable or fixed hoisting mechanism and traveling on the lower flanges of an overhead runway (see Figs. 17-0.2-4 and 17-0.2-9).

**crane, wall:** a crane with a jib and hoist, with or without a trolley, traveling on a runway attached to the sidewall or building columns.

**drift point:** a point on a travel motion master switch or on a manual controller that maintains the brake released



the motor is not energized. This allows for

**lift and drop section:** (also known as *lift section*) a mechanism that will permit a section of track(s) to be lifted or lowered out of alignment with the stationary track(s) (see Fig. 17-0.2-10).

**electric baffle:** conductors that are wired to cut off electric power to approaching motor-driven equipment if track switches, drop sections, and other movable track devices are not properly set for passage of equipment.

**end truck:** an assembly consisting of the frame and wheels that support the crane girder(s) and allow movement along the runway.

**fixed transfer section:** (also known as *crossover*) a connecting track with an interlock mechanism on both ends, mounted between two interlocking cranes, that is used to transfer a trolley from one bridge to the other.

**hanger:** a steel rod, together with other fittings, that is used to suspend the track from the supporting structure.

**hazardous (classified) locations:** locations where fire or explosion hazards may exist. Locations are classified depending on the properties of the flammable vapors, liquids, or gases, or the combustible dusts or fibers that may be present, and the likelihood that a flammable or combustible concentration or quantity is present (see ANSI/NFPA 70).

**hoist:** a machinery unit that is used for lifting or lowering a freely suspended (unguided) load.

**interlocking mechanism:** a mechanical device used to lock together the adjacent ends of two cranes or a crane to a fixed transfer section or spur track, to permit the transfer of trolleys from one crane or track to the other (see Fig. 17-0.2-11).

**jib boom:** a horizontal cantilever track for supporting the trolley (see Fig. 17-0.2-6).

**limit device:** a device that is operated by some part or motion of a power-driven hoist, trolley, or bridge to limit motion.

**load:** the total superimposed weight on the load block or hook.

**load bar:** a load-carrying member between trolleys.

**load block:** the assembly of hook or shackle, swivel, bearing, sheaves, pins, and frame suspended by the hoist rope or load chain. This shall include any appurtenances reeved in the hoisting rope or load chain.

**lockout/tagout:** the placement of a lock/tag on the energy-isolating device in accordance with an established procedure.

**master switch:** see *switch, master*.

**monorail:** a single run of overhead track on which trolleys travel, including curves, switches, transfer devices, and lift and drop sections.

**monorail system:** a machine for lifting and lowering a load and moving it horizontally, suspended from a single track.

**normal operating conditions (of cab-operated cranes or trolleys):** conditions during which a crane or trolley is performing functions within the scope of the original design. Under these conditions, the operator is at the operating control devices and no other person is on the crane or trolley.

**normal operating conditions (of floor-operated cranes or trolleys):** conditions during which a crane or trolley is performing functions within the scope of the original design. Under these conditions, the operator is at the operating control devices that are attached to the crane or trolley, but operated with the operator off the crane or trolley, and with no person on the crane or trolley.

**normal operating conditions (of remote-operated cranes or trolleys):** conditions during which a crane or trolley is performing functions within the scope of the original design. Under these conditions, the operator is at the operating control devices that are not attached to any part of the crane or trolley.

**pendant station:** controls suspended from the crane and/or hoist for operating the unit from the floor.

**push-button station:** an electrical control device consisting of push-button-operated contacts, in an enclosure used by the operator for control of the powered motions of the crane, carrier, hoist, and other auxiliary equipment.

**qualified person:** a person who, by possession of a recognized degree in an applicable field or certificate of professional standing, or by extensive knowledge, training, and experience, has successfully demonstrated the ability to solve or resolve problems relating to the subject matter and work.

**radio controlled:** operated from a radio transmitter located at a point not mechanically attached to the device being controlled.

**rail:** the structural member that supports the top running crane or trolley wheels.

**rail sweep:** a device attached to the crane and located in front of the crane's leading wheels to push aside loose obstructions.

**rated load:** the maximum load designated by the manufacturer or qualified person, for which the crane or monorail system is designed and built.

**remote controlled:** controlled by a control station located at a point not mechanically attached to the device being controlled.

**rope:** refers to wire rope, unless otherwise specified.

**runway:** an assembly of rails, tracks, beams, girders, brackets, and framework on which the crane travels.





service that involves operation within the limit that exceeds normal service.

*normal*: service that involves operation with randomly distributed loads within the rated load limit, or uniform loads of less than 65% of the rated load for not more than 15% of the time for manually operated hoists, and 25% of the time for electric or pneumatic-powered hoists of a single work shift.

*service, severe*: service that involves normal or heavy service with abnormal operating conditions.

*service platform*: a means provided for workers to perform maintenance, inspections, adjustments, and repairs of cranes.

*shall*: use of this word indicates that a rule is mandatory and must be followed.

*should*: use of this word indicates that a rule is a recommendation, the advisability of which depends on the facts in each situation.

*side pull*: the component of the hoist pull acting horizontally when the hoist lines are not operated vertically.

*span*: the horizontal distance, center to center, between runway rails.

*splice*: a mechanical device used to join the adjacent ends of track sections.

*spur track*: a fixed track arranged to interlock with an adjacent crane girder to permit passage of trolleys from the spur track to the crane, and vice versa.

*stop*: a device to limit travel of a trolley or crane and which normally does not have energy-absorbing ability.

*support system*: components whose sole purpose is to suspend or support the runway of an underhung crane, monorail, jib boom, or other equipment system components. These support system components include, but are not limited to, hanger rods, track hangers, clamps, sway bracing, and fasteners.

*switch (valve)*: a device for making, breaking, or changing the connections in an electric, hydraulic, or pneumatic circuit.

*switch, master*: a device that dominates the operation of contactors and auxiliary devices of an enclosed circuit.

*switch, master, spring-return*: a master switch that, when released, will return automatically to a neutral (OFF) position.

*switch, runway disconnect*: a switch, usually at floor level, controlling the main power supply to the runway conductors.

*switch, track*: a device with a moving section of track that can be moved to permit passage of a trolley from incoming fixed track(s) to outgoing fixed track(s).

*track*: the structural member that supports the trolley or crane wheels on underhung systems.

*track, enclosed*: a structural member, generally in the shape of a rectangular tube, with a continuous slot running lengthwise along the underside that permits end trucks or trolley(s) to travel on the interior bottom flange (see Fig. 17-0.2-12).

*track curves*: curved sections of monorail track used to change the direction of trolley travel.

*track opener*: a section of monorail track arranged to lift or swing out of line to make an opening through which a door may pass.

*trolley (carrier)*: the unit that travels on the lower or upper flange of the bridge girder and carries the hoist.

*trolley, automatic dispatch*: a trolley that, when activated, operates through a preset cycle or cycles.

*trolley, cab-operated*: a trolley controlled by an operator in a cab attached to the trolley (see Fig. 17-0.2-13).

*trolley, floor-operated*: a trolley that is controlled by a means suspended from the trolley or crane, or controlled from a wall-mounted station and operated by an operator on the floor or on an independent platform.

*trolley, hot molten material*: an overhead trolley used for transporting or pouring molten material.

*trolley, power-operated*: a trolley whose mechanism is driven by electric, pneumatic, or hydraulic means.

*trolley, pulpit-operated*: a trolley operated from a fixed operator station not attached to the trolley.

*trolley, remote-operated*: a trolley that is controlled by any method other than a means suspended from the trolley and operated by an operator not in a pulpit nor in the cab attached to the trolley.

*trolley travel*: the trolley movement in directions at right angles to the crane runway.

*unattended*: a condition in which the operator of a crane and/or hoist is not at the operating control devices. On a floor-operated crane, however, if the operating control devices are within sight of the operator and within a distance equal to the span of the crane, the crane should be considered attended.

### SECTION 17-0.3: REFERENCES

The following is a list of publications referenced in this Volume:

AA ADM-1-2010, Aluminum Design Manual  
Publisher: Aluminum Association, Inc. (AA), 1400  
Crystal Drive, Suite 430, Arlington, VA 22202  
(www.aluminum.org)

ANSI ECMA 15-2010, Specifications for Cable-less  
Controls for Electric Overhead Traveling Cranes

ANSI MH27.1-2009, Specifications for Underhung  
Cranes and Monorail Systems



- H27.2-2009, Specifications for Enclosed Track Underhung Cranes and Monorail Systems  
Publisher: Monorail Manufacturers Association, Inc. (MMA), 8720 Red Oak Boulevard, Suite 201, Charlotte, NC 28217 (www.mhi.org/mma)
- ANSI/ALI A14.3-2008, Safety Requirements for Fixed Ladders  
Publisher: American Ladder Institute (ALI), 330 North Wabash, Chicago, IL 60611 (www.americanladderinstitute.org)
- ANSI/ASCE 7-10, Minimum Design Loads for Buildings and Other Structures  
Publisher: American Society of Civil Engineers (ASCE), 1801 Alexander Bell Drive, Reston, VA 20191-4400 (www.asce.org)
- ANSI/AWS D1.1/D1.1M:2010, Structural Welding Code — Steel  
ANSI/AWS D14.1-2005, Specification for Welding of Industrial and Mill Cranes and Other Material Handling Equipment  
Publisher: American Welding Society (AWS), 8669 NW 36 Street, No. 130, Miami, Florida 33166-6672 (www.aws.org)
- ANSI/NEMA Z535.1-2006, Safety Colors  
ANSI/NEMA Z535.3-2011, Criteria for Safety Symbols  
ANSI/NEMA Z535.4-2011, Product Safety Signs and Labels  
Publisher: National Electrical Manufacturers Association (NEMA), 1300 North 17th Street, Rosslyn, VA 22209 (www.nema.org)
- ANSI/NFPA 70-2011, National Electrical Code  
Publisher: National Fire Protection Association (NFPA), 1 Batterymarch Park, Quincy, MA 02169 (www.nfpa.org)
- ASME B30.9-2010, Slings  
ASME B30.10-2009, Hooks  
ASME B30.16-2007, Overhead Hoists (Underhung)  
ASME B30.20-2013, Below-the-Hook Lifting Devices  
Publisher: The American Society of Mechanical Engineers (ASME), Two Park Avenue, New York, NY 10016-5990 (www.asme.org)
- ASSE A1264.1-2007, Safety Requirements for Workplace Walking/Working Surfaces and Their Access; Workplace Floor, Wall and Roof Openings, Stairs and Guardrails Systems  
ASSE Z244.1-2003, Control of Hazardous Energy Lockout/Tagout and Alternative Methods  
Publisher: American Society of Safety Engineers (ASSE), 520 N. Northwest Hwy, Park Ridge, IL 60068 (www.asse.org)
- ASTM E2349-12, Standard Practice for Safety Requirements in Metal Casting Operations: Sand Preparation, Molding, and Core Making; Melting and Pouring; and Cleaning and Finishing  
Publisher: American Society for Testing and Materials (ASTM International), 100 Barr Harbor Drive, P.O. Box C700, West Conshohocken, PA 19428 (www.astm.org)
- CMAA Specification No. 74-2009, Specifications for Top Running and Under Running Single Girder Electric Overhead Traveling Cranes Utilizing Under Running Trolley Hoist  
Publisher: Crane Manufacturers Association of America, Inc. (CMAA), 8720 Red Oak Boulevard, Charlotte, NC 28217 (www.mhi.org/cmaa)
- ISO 7000:2012, Graphical symbols for use on equipment — Registered symbols  
ISO 7296-1:1991, Cranes — Graphic symbols — Part 1: General  
Publisher: International Organization for Standardization (ISO), Central Secretariat, Chemin de Blandonnet 8, Case Postale 401, 1214 Vernier, Geneva, Switzerland (www.iso.org)
- Steel Construction Manual, 14th ed., 2011  
Publisher: American Institute of Steel Construction (AISC), One East Wacker Drive, Suite 700, Chicago, IL 60601 (www.aisc.org)
- SAE Z26.1-1996, Safety Glazing Materials for Glazing Motor Vehicle Equipment Operating on Land Highways — Safety Standard  
Publisher: Society of Automotive Engineers (SAE International), 400 Commonwealth Drive, Warrendale, PA 15096 (www.sae.org)

#### SECTION 17-0.4: PERSONNEL COMPETENCE

Persons performing the functions identified in this Volume shall meet the applicable qualifying criteria stated in this Volume and shall, through education, training, experience, skill, and physical fitness, as necessary, be competent and capable to perform the functions as determined by the employer or employer's representative.

Fig. 17-0.2-1 Examples of Styles of Electrification

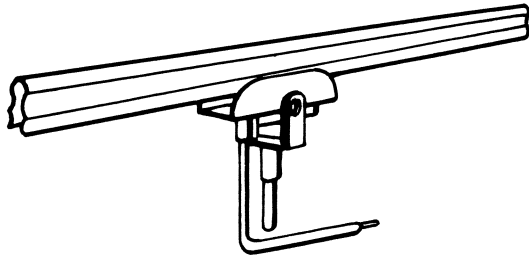

(a) Single Conductor (Bottom Entry)

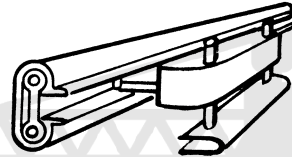

(b) Single Conductor (Side Entry)

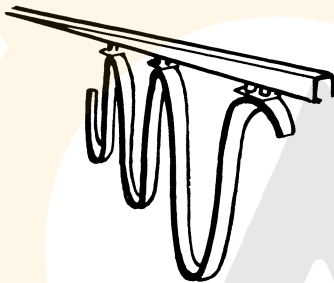

(c) Festooned Flat Cable

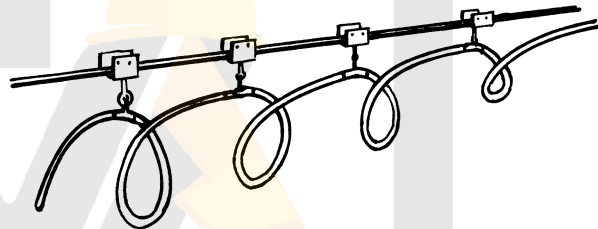

(d) Festooned Round Cable

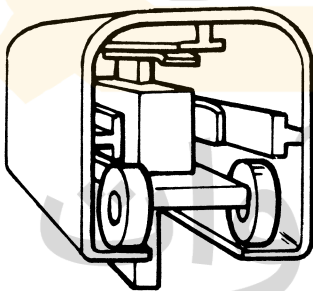

(e) Multi-Conductor Enclosed Bar

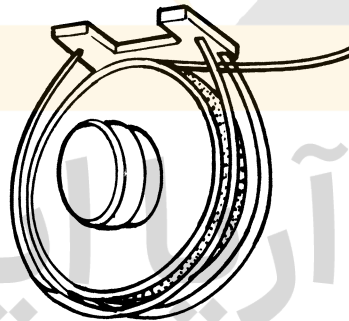

(f) Cable Reel

Fig. 17-0.2-2 Cab-Operated Crane

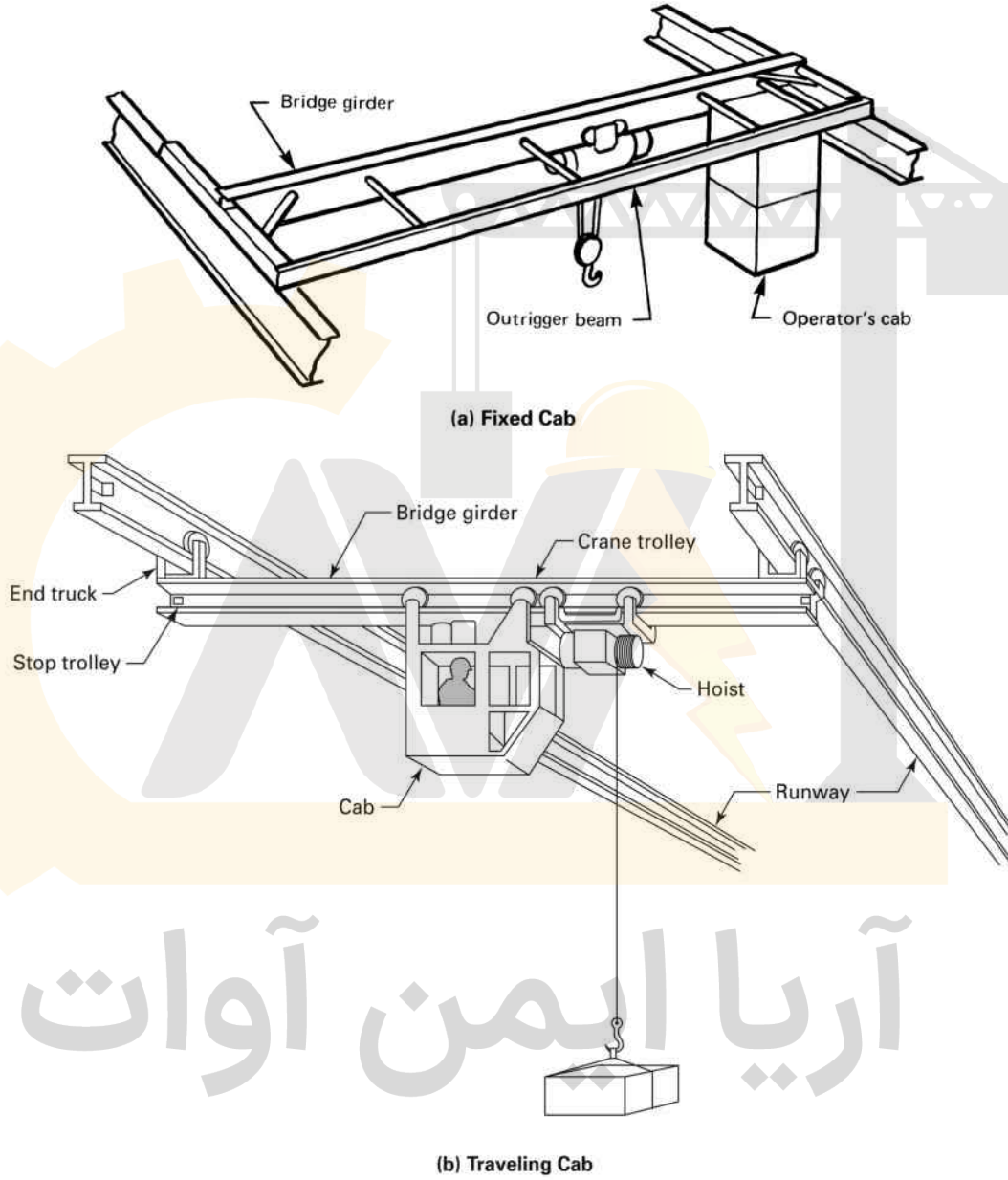

آریا ایمن آوات

Fig. 17-0.2-3 Cantilever Gantry Crane

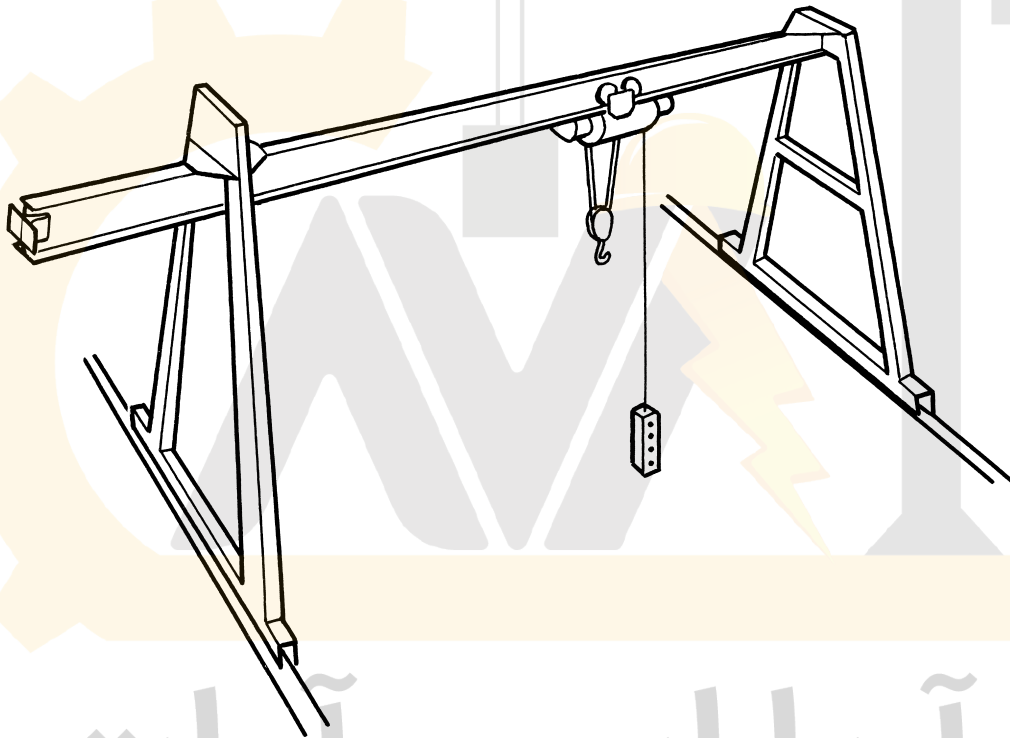
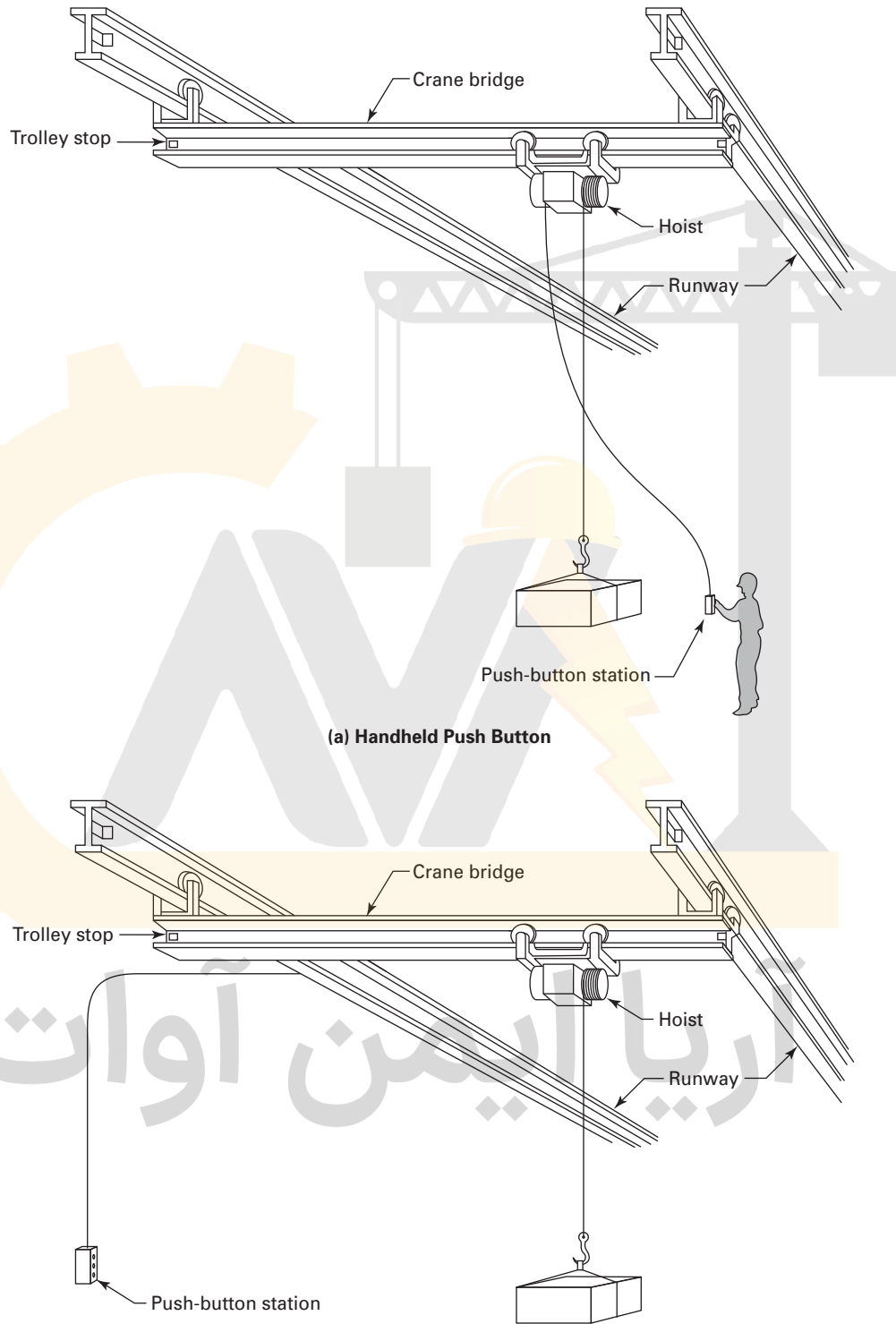

Fig. 17-0.2-4 Floor-Operated Cranes



(b) Wall-Mounted Push Button

Fig. 17-0.2-5 Gantry Crane

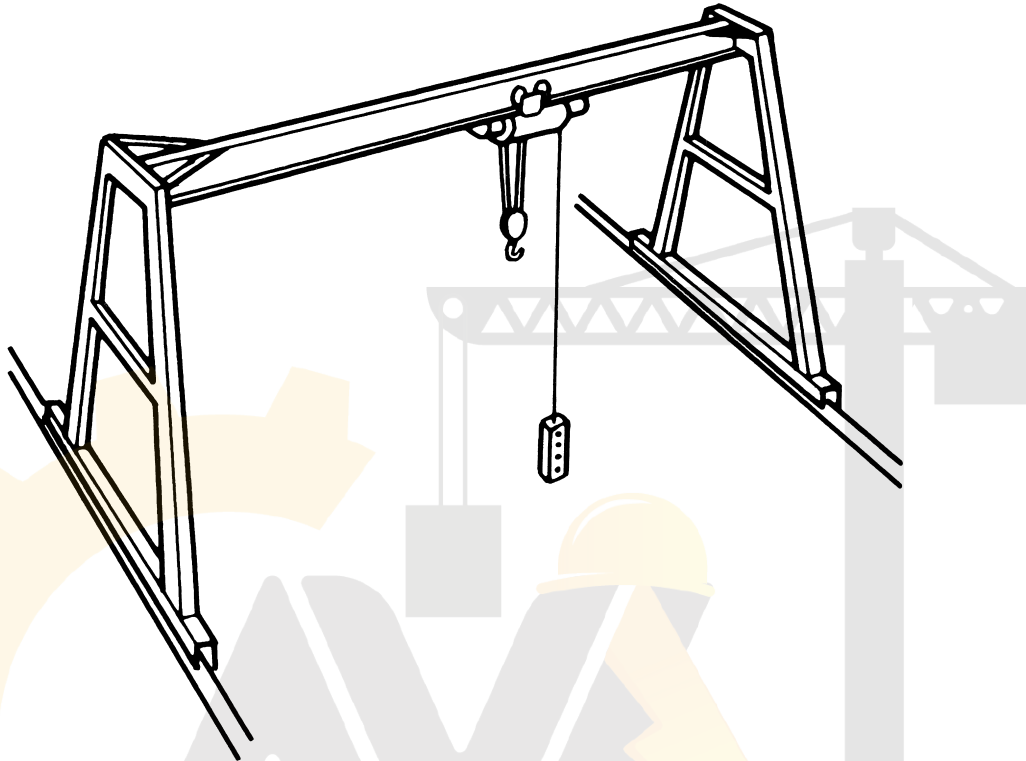

Fig. 17-0.2-6 Wall-Supported Jib Crane

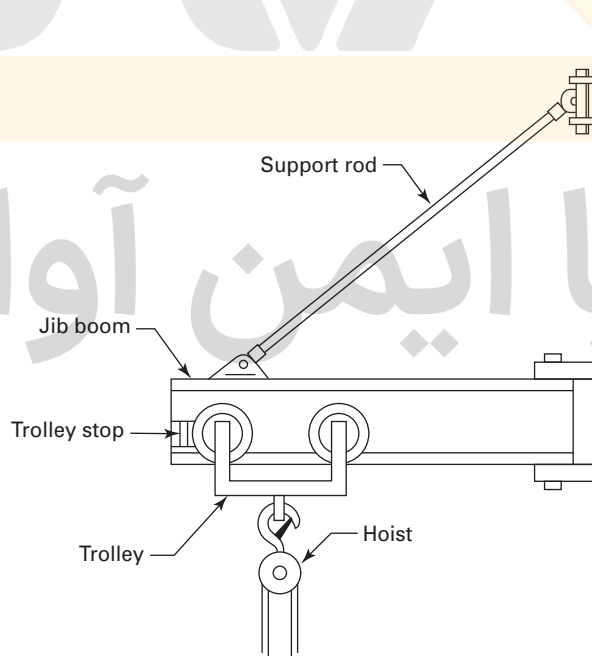

Fig. 17-0.2-7 Portable Gantry Crane (A-Frame)

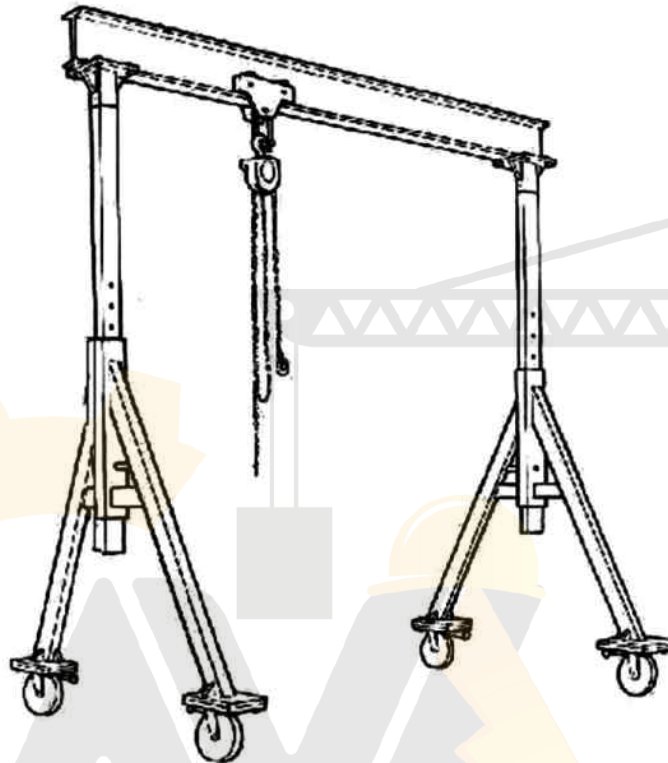

Fig. 17-0.2-8 Semigantry Crane

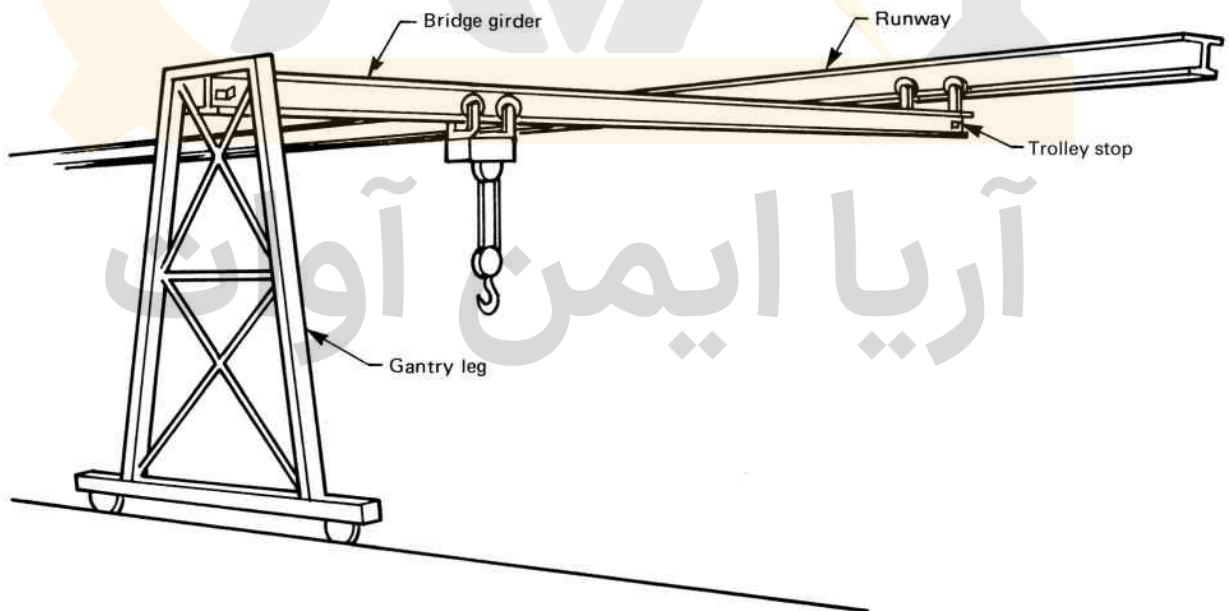



Fig. 17-0.2-9 Underhung Bridge Crane With Top Running Trolley

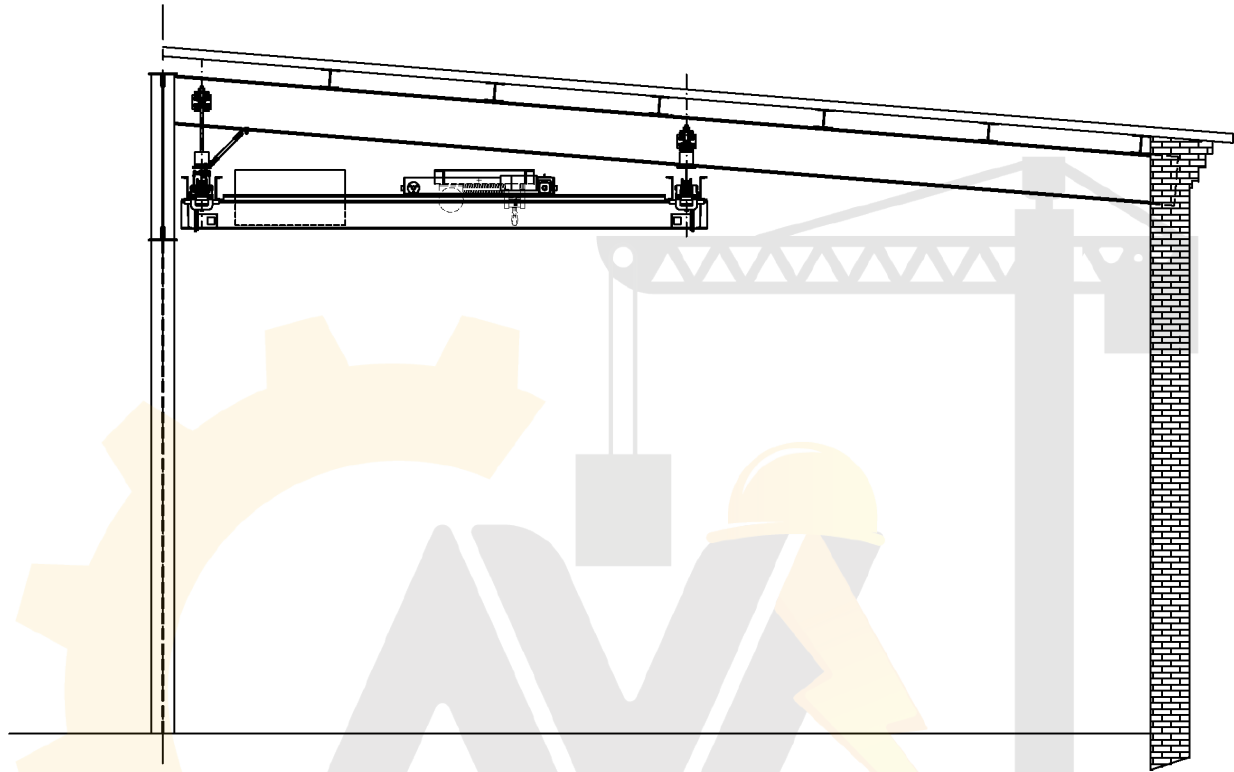

Fig. 17-0.2-10 Drop Section (Lift Section)

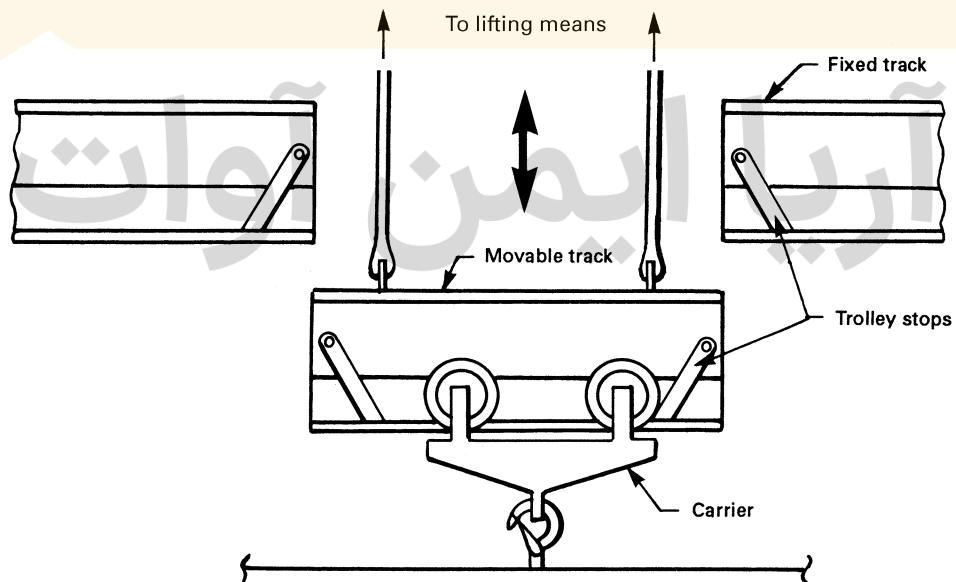

Fig. 17-0.2-11 Interlocking System for Underhung Crane

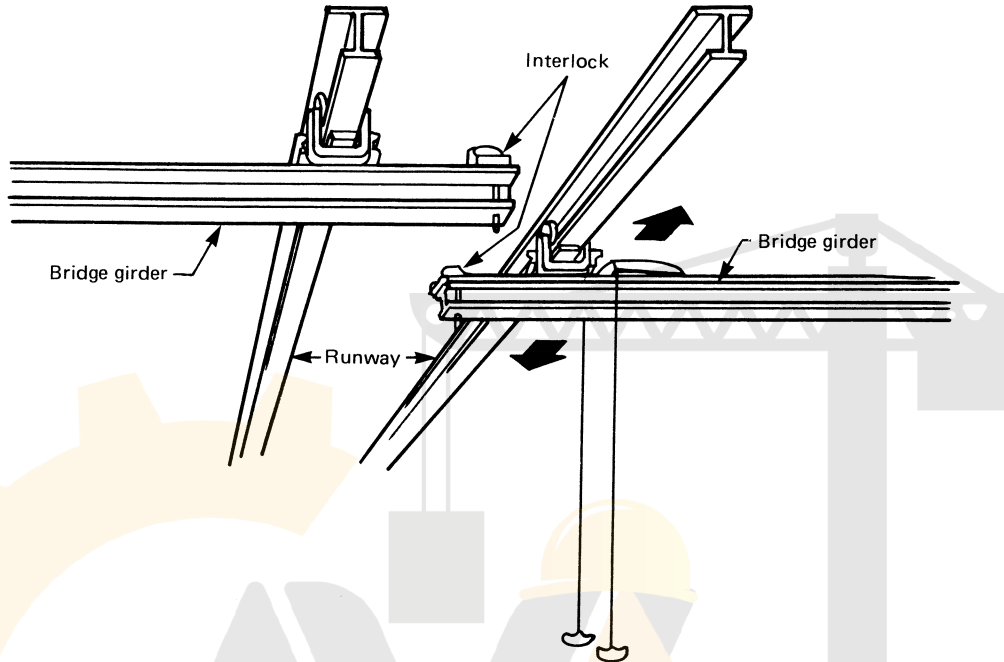

Fig. 17-0.2-12 Example of One Type of Enclosed Track and Support Bracket

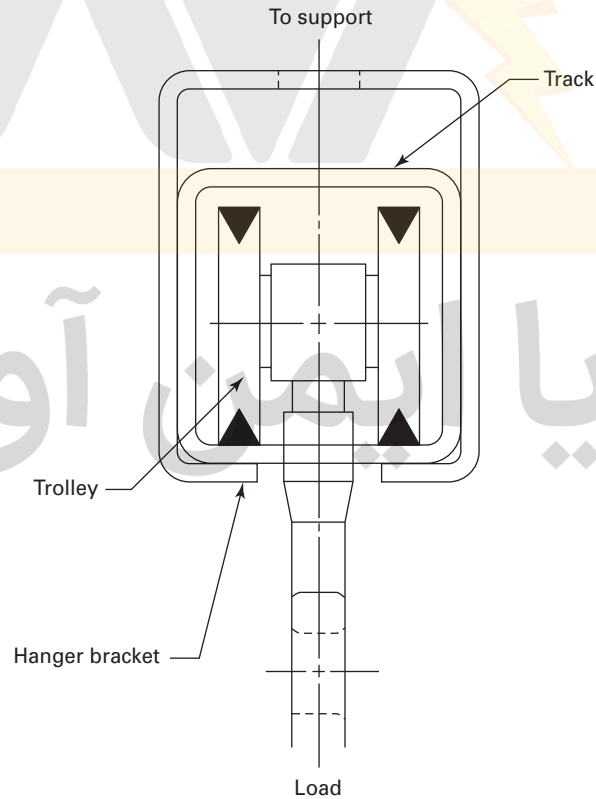
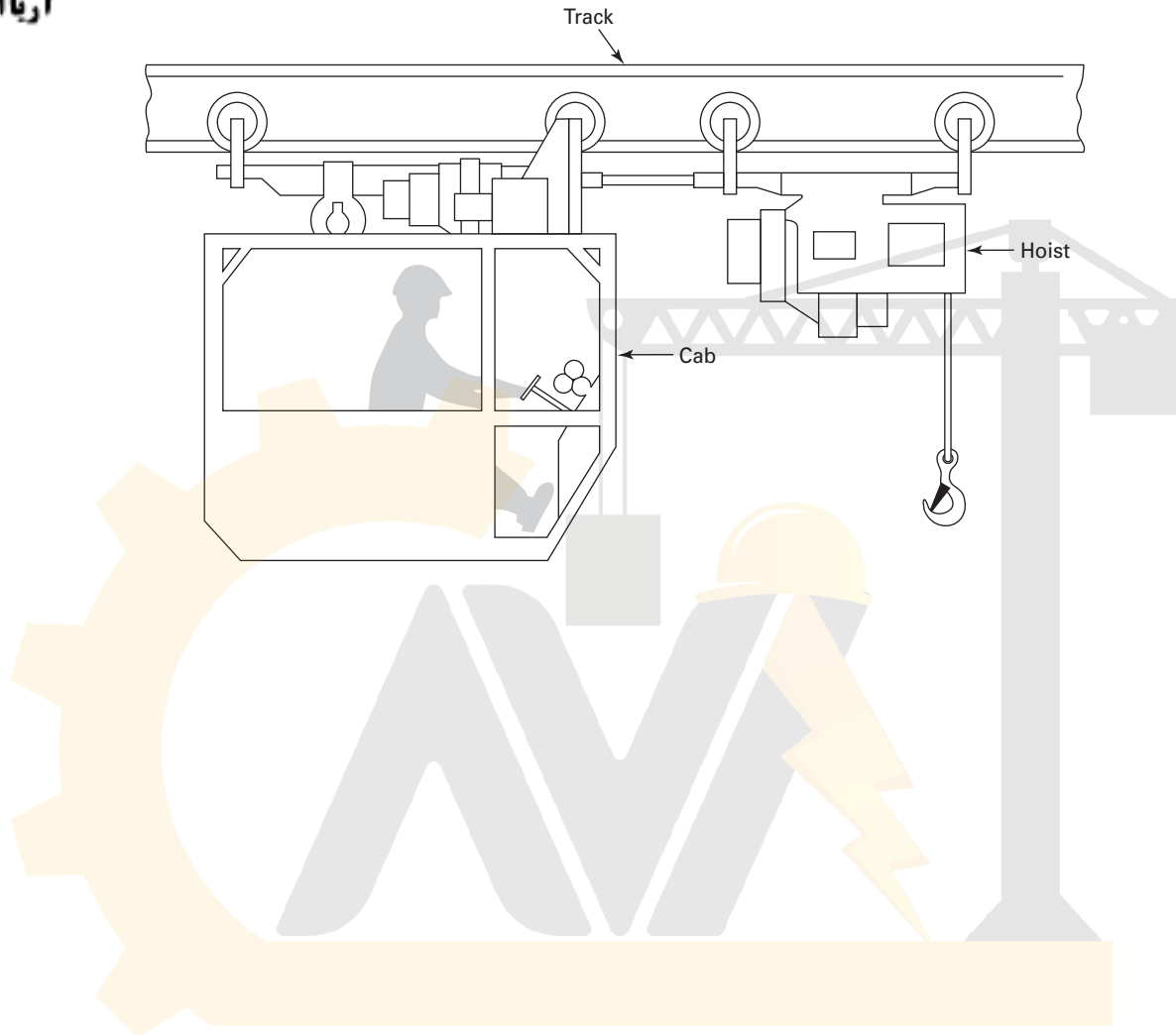

Fig. 17-0.2-13 Cab-Operated Trolley



آریا ایمن آوات



## Chapter 17-1 General Construction and Installation

(15)

### SECTION 17-1.1: MARKINGS

#### 17-1.1.1 Cranes

(a) The rated load shall be marked on each side of the crane, and if the crane has more than one hoisting unit, each hoist shall have its rated load marked on the hoist or its load block so that the rated load marking shall be legible from the ground or floor.

(b) The crane shall be marked with manufacturer's identification information on a plate or label attached to the crane, as follows:

- (1) name and address of manufacturer
- (2) manufacturer's unique identifier such as serial number

#### 17-1.1.2 Monorails

The rated load of the monorail should be marked on the monorail and, if marked, shall be legible from the ground or floor.

#### 17-1.1.3 Hoists

(a) The rated load of each hoist shall be marked in accordance with ASME B30.16.

(b) If there is more than one hoisting unit, each hoist shall have an identification marking on the hoist or trolley unit or its load block (e.g., #1 and #2, A and B, North and South, etc.) and shall be legible from the ground or floor. These markings shall also appear on the controllers used by the operator to indicate the controllers that operate each hoist.

#### 17-1.1.4 General Markings

Directional markings (i.e., North, South, East, and West; Forward and Reverse; or Left and Right) shall be provided on the equipment or facility. These markings shall be legible to the operator and consistent with the direction of movement markings on the controllers.

#### 17-1.1.5 Trolleys

The rated load, the equipment manufacturer's name, and the model or serial number shall be marked on each trolley.

#### 17-1.1.6 Warnings

(a) Hoist warnings are to be in accordance with ASME B30.16 and legible from the operating location.

(b) Electrical control enclosure warning labels shall be in compliance with ANSI/NEMA Z535.4 and ANSI/NFPA 70 and shall include, but not be limited, to the following:

(1) Disconnect power and lockout/tagout disconnecting means before removing cover or servicing this equipment.

(2) Do not operate without cover in place.

(c) All control panels and any other electrical equipment, such as switchboards and panelboards that are likely to require inspection, adjustment, servicing, or maintenance while energized, shall be marked to warn of potential electric arc flash hazards. The marking shall be located as to be clearly visible to personnel before inspection, adjustment, servicing, or maintenance of the equipment.

#### 17-1.1.7 Controls

(a) Each controller shall be legibly marked to indicate the function and direction of movement.

(b) In locations or areas where multiple systems are used, the arrangement of control markings for function and directions should be the same for all crane and monorail systems in that location or area.

### SECTION 17-1.2: CLEARANCES

#### 17-1.2.1 Clearance From Obstruction

(a) Clearance shall be maintained between the crane or monorail systems and any potential obstructions, as well as cranes operating at different elevation(s), under all operating conditions. In the design of new cranes or monorails, all factors that influence clearance, such as wheel float, truss sag, bridge or trolley skewing, or trolley positions and configurations, shall be considered.

(b) Where passageways or walkways are provided on the structure supporting the crane, obstructions shall not be placed so that personnel will be jeopardized by movements of the crane.

#### 17-1.2.2 Clearance Between Parallel Cranes

(a) If the runways of two non-interlocking cranes are parallel and there are no intervening walls or structures, clearance shall be provided and maintained between the two cranes.

(b) Where multiple cranes on parallel runways are designed for interlocking transfer of the trolley(s), means



provided to maintain clearance between the rails at the interlocking ends of the crane girders so that they do not strike each other when passing.

(2) do not strike a fixed interlocking crossover or spur track.

### 17-1.2.3 Clearance at Curves

Clearances shall be provided at the curves of a monorail system to allow for the swing of the load when negotiating the curve. The amount of clearance shall be determined by giving due consideration to the size, weight, and speed of the trolley and the radius of the track curve.

## SECTION 17-1.3: GENERAL CONSTRUCTION

### 17-1.3.1 Crane Runways and Monorail Tracks

(a) Crane runways, monorails, support systems, and supporting structures shall be designed to withstand the loads and forces imposed by the cranes and trolleys. Steel crane runways and supporting structure should conform to the design parameters as specified in the applicable Steel Construction Manual.

(b) The structure shall be free from excessive vibrations under normal operating conditions.

(c) If I-beams are to be used for the runway, monorail, or jib boom, Section 3 of CMAA Specification No. 74 should be considered for design purposes.

(d) Rails shall be level, straight, spliced, and spaced to crane span within recommended tolerances as specified in CMAA Specification No. 74, or within tolerances specified by the crane manufacturer or a qualified person.

(e) Where curves are required, special design will be necessary.

(f) Where change in elevation of the track is required, special design will be necessary.

### 17-1.3.2 Track Supports

(a) Tracks shall be fastened to a supporting structure by means of a support system.

(b) Hanger rods shall be installed plumb within the manufacturer's tolerances.

(c) Where multiple hanger rods are used at a suspension point, consideration should be given to the unequal load induced in the rods.

(d) Means shall be provided to restrain the track against damaging lateral and longitudinal movement.

(e) Where the track is suspended from hanger rod assemblies, restraining means shall be provided to prevent the hanger rod nuts from backing off the hanger rods.

(f) All track and track supports shall conform to the minimum design parameters as specified in ANSI MH27.1, ANSI MH27.2, Steel Construction Manual, the

Aluminum Design Manual, or applicable design manual or standard for the material used.

### 17-1.3.3 Foundations and Anchorage

(a) Every outdoor crane shall be provided with a means to secure the crane against a wind pressure of 30 lb/ft<sup>2</sup> (1.436 kPa). Parking brakes may be considered to provide minimum compliance with this rule.

(b) Where wind forces are specified to be in excess of 30 lb/ft<sup>2</sup> (1.436 kPa), special anchorages such as latches or tie downs at the home position or remotely operated rail clamps for all positions to supplement the primary braking system shall be provided (ANSI/ASCE 7 may be used as a reference for this condition).

(c) Rail clamps should only be applied when the crane is not in motion.

(d) When rails are used for anchorages, they shall be secured to withstand the resultant forces applied by the rail clamps. If the clamps act on the rail, any projection or obstruction in the clamping area shall be avoided.

(e) Other than portable gantries, a wind speed indicating device shall be provided for cranes used outdoors. The device should be mounted on the crane or the crane runway structure and shall give a visible and audible alarm to the crane operator at a predetermined wind speed. A single wind speed indicating device may serve as an alarm for more than one crane.

### 17-1.3.4 Cranes and Monorail Systems

Cranes and monorail systems should conform to the minimum design parameters as specified in the Manual of Steel Construction, CMAA Specification No. 74, ANSI MH27.1, or ANSI MH27.2, as applicable.

### 17-1.3.5 Welded Construction

Welding procedures and welding operator qualifications to be used on load-sustaining members shall be in accordance with ANSI/AWS D1.1/D1.1M, except as modified by ANSI/AWS D14.1. Where special steels or other materials are used, the manufacturer or qualified person shall provide welding procedures. Field welding of track supports shall be in accordance with ANSI/AWS D1.1/D1.1M.

### 17-1.3.6 Modifications

Cranes and monorail systems may be modified or rerated, provided such modifications and the supporting structure are analyzed by a qualified person or manufacturer of the equipment. A rerated system or one whose load-supporting components have been modified shall be tested in accordance with Section 17-2.2. The new rated load shall be displayed in accordance with Section 17-1.1.



## 17-1.4: TRACK SWITCHES, TRACK OPENERS, AND INTERLOCKS

### 17-1.4.1 Track Switches

(a) Track switches shall be constructed and installed to maintain alignment with incoming and outgoing tracks. Control chains or ropes for hand-operated track switches, push buttons for electrically operated track switches, and operator-controlled valves for pneumatic or hydraulically operated track switches shall be located within reach of the operator.

(b) Stops shall be provided as an integral part of the switch to protect the end of an incoming track when the switch track is not aligned with the incoming track.

(c) Track switches should not be capable of being shifted with a trolley on the movable track. Means shall be provided to prevent a trolley on the movable track from running off the movable track when it is not aligned with an outgoing track.

(d) Means shall be provided to hold the movable frame in a stationary position during passage of trolleys through the track switch.

(e) Electric baffles shall be provided on track switches and incoming tracks on systems with cab control, automatic dispatch trolleys, or molten material trolleys as required in ASTM E2349. Baffles shall prevent trolley contact with the end of an incoming track when the switch track is not aligned with the incoming track. Baffles shall also prevent the trolley from interfering with a trolley on an adjacent track.

### 17-1.4.2 Stops at Track Openers

Stops shall be provided to prevent a hoist/trolley from running off either of the open ends of the track when the movable section is not in alignment with the track.

### 17-1.4.3 Interlocks

(a) Interlocking mechanisms for transfer and interlocking cranes shall maintain alignment of the bridge girder(s) with spur tracks, fixed transfer sections, or bridge girder(s) of interlocking cranes operating on adjacent runways to permit the transfer of a trolley from one to the other.

(b) Stops shall be an integral part of the interlock mechanism. When bridge girders and spur tracks or fixed transfer sections are aligned and interlock mechanisms are engaged, stops shall be in the open position to permit transfer of a trolley from one track, bridge girder, or section to the other. When bridge girders and spur tracks or fixed transfer sections are not aligned, or interlock mechanisms are disengaged, stops shall be in the closed position and shall prevent trolleys from rolling off the end of spur tracks, transfer sections, or bridge girders.

## SECTION 17-1.5: VERTICAL DROP OR LIFT SECTIONS

### 17-1.5.1 Trolley Passage

Vertical drop or lift sections shall maintain alignment of the fixed tracks and the movable tracks to enable the passage of a trolley.

### 17-1.5.2 Trolley Run-Off Protection

Means shall be provided to prevent a trolley from running off either end of the movable track when the movable track is not in alignment with the fixed tracks.

### 17-1.5.3 Stops

Stops shall prevent a trolley from running off the open ends of the fixed tracks when the movable track is not in alignment with the fixed tracks.

### 17-1.5.4 Electric Baffles

Electric baffles shall be provided on fixed and movable tracks on systems with cab-operated trolleys, automatic dispatch trolleys, or molten material trolleys. They shall limit trolley travel when the movable track is not in alignment with the fixed track.

## SECTION 17-1.6: CABS — NORMAL OR SKELETON (IF PROVIDED)

### 17-1.6.1 Cab Location and Internal Arrangement

(a) The general arrangement of the cab and the location of the control and protective equipment should be such that all operating control devices are within reach of the operator when facing the area to be served by the load block or while facing in the direction of travel of the cab.

(b) The arrangement of the cab should allow the operator to view the load block in all positions. When physical arrangements obscure the operator's view, the operator shall be aided by other means such as, but not limited to, closed circuit TV, mirrors, radio, telephone, or a signalperson.

(c) The cab shall be clear of all fixed structures within its area of movement.

(d) The clearance of the cab above the working floor or passageway should be not less than 7 ft (2.1 m), except when operations require dimensions that are less. In this case, precautions shall be taken during the operation of the crane or trolley to keep personnel and other obstructions clear of the low overhead cab.

### 17-1.6.2 Cab Construction

(a) Where the cab operates on a single track, the cab may be mounted on a separate trolley or can be an integral part of the hoist trolley. On double-girder cranes, the cab shall be rigidly attached to the trolley or the crane to minimize swing.



Integral outside platform is provided, the door (if provided) shall slide or open outward. In the absence of an outside platform, the door, if provided, shall open inward or slide and shall be self-closing. It shall be equipped with a positive latching device to prevent inadvertent opening.

(d) The width of a doorway shall have a clear opening of no less than 18 in. (460 mm).

(e) A trap door, if provided above the cab or in the cab roof, shall have a clear opening of no less than 24 in. (610 mm) on each side. There should be no obstructions to prevent complete opening of the trap door.

(f) Guard railings and toeboards shall be in compliance with ASSE A1264.1.

(g) Outdoor cabs should be enclosed. All cab glazing shall be safety glazing material as defined in ANSI/SAE Z26.1.

(h) The cab construction shall offer protection from falling objects, if this possibility exists. The protection shall support a minimum static load of 50 lb/ft<sup>2</sup> (2.4 kPa).

(i) If the cab of a molten material crane is exposed to or near heat, it shall be provided with the following protection as determined by a qualified person:

(1) a heat shield located between the cab and heat source

(2) a floor insulated with heat-resistant material

(3) shielded or heat- and spatter-resistant clear panels or heat screens, where required, to provide operator vision and protection

(4) windows with metal sash and heat-resisting safety glazing material, as defined in ANSI/SAE Z26.1

(5) materials that will not propagate combustion or rekindle

#### 17-1.6.3 Access to Cab

Access to the cab shall be by a fixed ladder, stairs, or platform requiring no step over any gap exceeding 12 in. (305 mm). Fixed ladders shall be in conformance with ANSI/ALI A14.3.

#### 17-1.6.4 Toolbox

If a receptacle is provided for the stowing of tools and oil cans, it shall be made of a noncombustible material and shall be fastened in the cab or on the service platform.

#### 17-1.6.5 Fire Extinguisher

A portable fire extinguisher, with a basic minimum extinguisher rating of 10 BC, shall be installed in the cab.

#### 17-1.6.6 Lighting

Cab lighting, either natural or artificial, shall provide a level of illumination that enables the operator to observe the operating controls.

#### 17-1.6.7 Egress

A means of egress from cab-operated cranes or trolleys shall be provided to permit evacuation under emergency conditions.

### SECTION 17-1.7: LUBRICATION

If lubrication is required, accessible means for lubrication should be provided.

### SECTION 17-1.8: SERVICE PLATFORMS (FOOTWALKS)

#### 17-1.8.1 Construction of Service Platforms

Service platforms, when provided with or added to the crane, and attached to the crane, shall conform to the following requirements:

(a) The dimension of the working space in the vertical direction from the floor surface of the platform to the nearest overhead obstruction shall be a minimum of 48 in. (1.22 m) at the location where a person is performing a function while on the crane. Overhead platform clearance should be a minimum of 78 in. (1 980 mm). Where overhead clearance is less than 78 in. (1 980 mm), see para. 17-4.2.3(a)(10).

(b) Service platforms shall have a clear passageway at least 18 in. (457 mm) wide, except at the bridge drive mechanism, where not less than 15 in. (380 mm) of clear passageway shall be allowed.

(c) The dimension of the working space in the direction of access to live (energized) electrical parts that are likely to require examination, adjustment, servicing, or maintenance while energized, shall be a minimum of 30 in. (762 mm).

(d) The door(s) of electrical control cabinets shall either open at least 90 deg or be removable.

(e) Service platforms shall be designed to sustain a distributed load of at least 50 lb/ft<sup>2</sup> (2.4 kPa).

(f) Service platforms shall have a slip-resistant walking surface.

(g) Service platforms shall be provided with guard railings and toeboards.

(1) Guard railings and toeboards shall be in compliance with ASSE A1264.1.

(2) Guard railings shall be at least 42 in. (1 065 mm) high and provided with an intermediate railing.

### SECTION 17-1.9: STOPS AND BUMPERS

#### 17-1.9.1 Runway Stops

(a) Stops shall be provided to prevent motion beyond the limits of travel of the bridge.

(b) Stops shall be provided at open ends of tracks, interlocking crossovers, track spurs, track openers, and track switches.



Stops shall engage the bumper or bumper pads mounted on a power-driven bridge and withstand the forces applied to the bumpers.

(d) On a hand-operated bridge, the stops should engage parts of the crane other than the wheel. If a stop engages the tread of the wheel, its height shall be no less than the radius of the wheel.

### 17-1.9.2 Trolley Stops

(a) Stops shall be provided to prevent motion beyond the limits of travel of the trolley.

(b) Stops shall be provided at open ends of tracks, interlocking crossovers, track spurs, track openers, and track switches.

(c) Stops shall engage the bumper or bumper pads mounted on a power-driven trolley and withstand the forces applied to the bumpers.

(d) On a hand-operated trolley, the stops should engage parts of the trolley other than the wheel. If a stop engages the tread of the wheel, its height shall be no less than the radius of the wheel.

### 17-1.9.3 Bridge Bumpers

(a) A power-operated bridge shall be provided with bumpers or other automatic means providing equivalent effect.

(b) Bridge bumpers shall have the following minimum characteristics:

(1) energy-absorbing (or energy-dissipating) capacity to stop the bridge when traveling with power off in either direction at a speed of at least 40% of rated load speed

(2) capability of stopping the bridge (but not the load block or lifted load) at a rate of deceleration not to exceed an average of  $3 \text{ ft/sec}^2$  ( $0.9 \text{ m/s}^2$ ) when traveling with power off in either direction at 20% of rated load speed

(3) design and installation with a means of retaining the bumper in case of broken or loosened mounting connections

(c) Multiple power-operated bridges operating on the same runway shall have contact bumpers that meet the requirements of para. 17-1.9.3(b)(2).

(d) Consideration should be given to providing bumpers with greater capacity for energy absorption (or energy dissipation) than that specified in para. 17-1.9.3(b)(1) and providing bridge end stops with corresponding increased strength when any of the following conditions are present:

(1) crane has a maximum bridge speed of 320 ft/min (100 m/min) or greater

(2) crane is a remote-operated crane

(3) crane is a pulpit-operated crane

(4) location of the runway end stops is obscured or uncertain

(5) crane is a cab-operated crane

### 17-1.9.4 Trolley Bumpers

(a) A power-operated trolley shall be provided with bumpers or other automatic means providing equivalent effect.

(b) Trolley bumpers shall have the following minimum characteristics:

(1) energy-absorbing (or energy-dissipating) capacity to stop the trolley when traveling with power off in either direction at a speed of at least 50% of rated load speed

(2) capability of stopping the trolley (not including load block and lifted load) at a rate of deceleration not to exceed an average of  $4.7 \text{ ft/sec}^2$  ( $1.4 \text{ m/s}^2$ ) when traveling with power off at one-third of rated load speed

(3) a design and installation with a means of retaining the bumper in case of broken or loosened mounting connections

(c) Multiple power-operated trolleys operating on the same bridge shall have contact bumpers that meet the requirements of para. 17-1.9.4(b)(2).

(d) Consideration should be given to providing bumpers with greater capacity for energy absorption (or energy dissipation) than that specified in para. 17-1.9.4(b)(1) and providing trolley end stops with corresponding increased strength when any of the following conditions are present:

(1) trolley has a maximum speed of 150 ft./min (46 m/min) or greater

(2) trolley is on a remote-operated crane

(3) trolley is on a pulpit-operated crane

(4) location of the trolley end stops is obscured or uncertain

(5) crane is a cab-operated crane

### SECTION 17-1.10: RAIL SWEEPS

(a) Bridge truck rail sweeps shall be provided in front of the leading wheels on both ends of top running bridge end trucks.

(b) Trolley rail sweeps shall be provided in front of the leading wheels on both ends of top running trolleys.

(c) The rail sweep shall clear the rail of objects on the runway that, if they came into contact between the wheel and rail, could cause damage to the wheel or derail the wheel.

(1) Clearance between the top surface of the rail head and the bottom of the sweep should not exceed  $\frac{3}{16}$  in. (5 mm).

(2) Clearance between the vertical inside surfaces of the sweep should be equal to the wheel tread width plus  $\frac{3}{8}$  in. (10 mm) and clearance should be evenly spaced on each side of the wheel tread width.

(d) On bridge crane end trucks, the sweep shall extend below the top surface of the rail head, for a distance no less than 50% of the thickness of the rail head on both sides of the rail head.





running trolleys, the sweep shall extend above the top surface of the rail head for a distance not less than 50% of the thickness of the rail head on both sides of the rail head.

(f) On gantry crane end trucks, when the rail head is located above the pavement or ground level, the sweep shall extend below the top surface of the rail head for a distance not less than 50% of the thickness of the rail head on both sides of the rail head.

## SECTION 17-1.11: GUARDS

### 17-1.11.1 Guards for Moving Parts

(a) Exposed moving parts such as gears, set screws, projecting keys, chains, chain sprockets, and reciprocating components that constitute a hazard under normal operating conditions shall be guarded.

(b) Each guard shall be capable of supporting 200 lb (90 kg) without permanent deformation, unless the guard is located where it is not probable for a person to step on.

### 17-1.11.2 Guards for Hoisting Ropes

(a) If it is possible for hoisting ropes to foul or chafe on adjacent parts of the crane under normal operating conditions, guards shall be installed to minimize damage to the rope.

(b) A guard shall be provided to prevent contact between bridge or runway conductors and hoisting ropes, if they can come into contact under normal operating conditions.

## SECTION 17-1.12: DROP PROTECTION

(a) Means shall be provided to limit the drop of bridge end trucks to 1 in. (25.4 mm) in case of wheel, axle, or load bar failure. Drop protection for underhung bridge end trucks shall be located on both sides of the track to provide central loading of the track about the vertical axis if failure occurs.

(b) Means should be provided to limit the drop of a trolley in case of wheel, axle, or load bar failure. Drop protection, if provided, shall limit the drop of a trolley to 1 in. (25.4 mm) and shall be located on both sides of the track to provide central loading of the track about the vertical axis if failure occurs.

## SECTION 17-1.13: BRAKES

### 17-1.13.1 Hoist Brakes

Hoist brakes shall meet the requirements of ASME B30.16.

### 17-1.13.2 Trolley Brakes and Braking Means

(a) Each power-driven trolley unit of the crane shall either be equipped with a braking means or have trolley

drive frictional characteristics that will provide the following stopping and holding functions, under conditions where the rails are dry and free of snow and ice:

(1) torque capability to stop trolley travel within a distance in ft (m) equal to 10% of rated load speed in ft/min (m/min), when traveling at full speed with rated load and with the power off

(2) torque capability to prevent horizontal motion of the trolley against a horizontal force equal to 1% of the combined weight of the trolley, hoist, and rated load when the trolley is in a parked condition

(b) A power-driven cab-operated crane with the cab on the trolley shall be equipped with a trolley brake that will provide the stopping and holding functions described in paras. 17-1.13.2(a)(1) and (a)(2).

(c) Each trolley brake shall have thermal capacity for the frequency of operation required by the service.

### 17-1.13.3 Bridge Brakes and Braking Means

(a) A power-driven bridge shall either be equipped with a braking means or have bridge drive frictional characteristics that will provide the following stopping and holding functions, under conditions where the rails are dry and free of snow and ice:

(1) torque capability to stop bridge travel within a distance in ft (m) equal to 10% of rated load speed in ft/min (m/min), when traveling at full speed with rated load and with the power off.

(2) torque capability to prevent horizontal motion of the bridge against a horizontal force equal to 1% of the combined weight of the bridge, trolley, hoist, and rated load when the bridge is in a parked condition

(b) A power-driven, cab-operated crane with the cab on the bridge shall be equipped with a bridge brake that will provide the stopping and holding functions described in paras. 17-1.13.3(a)(1) and (a)(2).

(c) Each bridge brake shall have thermal capacity for the frequency of operation required by the service.

### 17-1.13.4 Trolley and Bridge Brake Provisions

The general provisions outlined below apply to trolley and bridge brakes.

(a) Brakes shall be provided with means of adjustment to compensate for lining wear.

(b) Brake pedals, latches, and levers should allow release without the exertion of greater force than was used in applying the brake.

(c) Foot-operated brakes shall require an applied force of not more than 70 lb (310 N) to develop rated brake torque.

(d) Foot-operated brake pedals shall be so constructed that the operator's foot will not readily slip off the pedal.

(e) Foot-operated brake pedals shall be so located that they are readily accessible to the operator at the controls.



not-operated brakes shall be equipped with a pedal for positive release when force is released from pedal.

- (g) When provided, a parking brake shall
- (1) be applied automatically or manually
  - (2) prevent horizontal motion of the trolley or bridge in accordance with the requirements of para. 17-1.13.2(a)(2) or 17-1.13.3(a)(2)
  - (3) not prohibit the use of a drift point in the control circuit

## SECTION 17-1.14: ELECTRICAL EQUIPMENT

### 17-1.14.1 General

- (a) Wiring and equipment shall comply with ANSI/NFPA 70.
- (b) The control circuit voltage shall not exceed 600 V for AC or DC.
- (c) The voltage at pendant push buttons shall not exceed 150 V for AC or 300 V for DC.
- (d) Where multiple-conductor cable is used with a suspended push-button station, the station shall be supported so that electrical conductors are protected from strain.
- (e) Pendant control stations shall be constructed to prevent electrical shock. The push-button enclosure shall be at ground potential and marked for identification of functions.
- (f) When equipment is used in hazardous locations as defined by ANSI/NFPA 70, modifications to these rules or additional safety requirements may be necessary. In these locations, cranes shall be designed and installed in a manner suitable for the conditions encountered.

### 17-1.14.2 Equipment

- (a) Electrical equipment shall be so located or enclosed such that personnel will not be exposed to inadvertent contact with energized parts under normal operating conditions.
- (b) Energized parts of electrical equipment shall be protected from direct exposure to grease, oil, and moisture, and they should be protected from dirt.
- (c) Guards for energized parts, if provided, shall be constructed or located so that they cannot be inadvertently deformed so as to make contact with energized parts.
- (d) Working space in the direction of access to energized parts that are likely to require inspection, adjustment, servicing, or maintenance, including all bridge-mounted control panel enclosures or switching devices, shall be a minimum of 30 in. (762 mm) from the surface of the enclosure or panel door. In addition, the work space in front of the enclosure or panel shall be at least as wide as the enclosure and shall be not less than 30 in. (762 mm) wide.

### 17-1.14.3 Controllers

(a) Cranes not equipped with spring-return controllers, spring-return master switches, or momentary contact push buttons shall be provided with a device that will disconnect all motors from the line in the event of a power failure. The disconnect device shall not permit any motor to be restarted until the controller or master switch handle is brought to the OFF position, or a reset switch or power-on button is operated.

#### (b) Cab-Operated Controls

- (1) Lever-operated manual controllers and master switches shall be provided with an OFF-position notch or latch. A spring return to the OFF position is acceptable.
- (2) The operating handle for a manual controller or master switch shall be located within reach of the operator.
- (3) The movement of the handle of each manual controller or master switch should be in the same general direction as the resultant movements of the load, except as shown in Figs. 17-1.14.3-1 and 17-1.14.3-2.

(4) The arrangement of controllers or master switches should conform to Figs. 17-1.14.3-1 and 17-1.14.3-2. Compass directions may be substituted for "Right-Left" and "Forward-Reverse" in Fig. 17-1.14.3-3, and for the W, X, Y, and Z designations in Fig. 17-1.14.3-4.

#### (c) Floor-Operated Controls

- (1) The controller or controllers, if rope operated, shall automatically return to the OFF position when released.
- (2) Push buttons in pendant stations shall return to the OFF position when pressure is released by the crane operator.

(3) The arrangement of pendant push buttons should conform to Fig. 17-1.14.3-3. Compass directions may be substituted for "Right-Left" and "Forward-Reverse" in Fig. 17-1.14.3-3, and for the W, X, Y, and Z designations in Fig. 17-1.14.3-4.

#### (d) Automatic and Remote Controls

(1) Automatic cranes or trolleys shall be so designed that operation of all motions shall be discontinued if the automatic sequence control becomes ineffective. Completion of the last command is permissible if power is available.

(2) Remote-operated cranes or trolleys shall function so that if the control signal for any crane or trolley motion becomes ineffective, that crane or trolley motion shall stop. Conversely, signals received from any source other than the operating station shall not result in operation of any motion of the crane or trolley.

(e) The arrangement of pendant push-button stations and radio-controlled transmitters should conform to Figs. 17-1.14.3-3 and 17-1.14.3-4, respectively. Compass directions may be substituted for "Right-Left" and "Forward-Reverse" in Fig. 17-1.14.3-3, and for the W, X, Y, and Z designations in Fig. 17-1.14.3-4.



s using radio controls shall be provided in with ANSI ECMA 15.

minimum of two collectors for each runway conductor shall be furnished when the crane uses inverters.

(h) Push buttons of pendant stations shall be guarded or shrouded to prevent accidental actuation of crane motion.

(i) Overspeed protection shall be provided when inverters (variable frequency drives) are used. Dynamic braking resistors may be considered as overspeed protection for traversing drives.

#### 17-1.14.4 Resistors (When Provided)

(a) Resistor units shall be supported to minimize the effect of vibration.

(b) Provisions shall be made to prevent broken parts or molten metal from falling upon the operator or from the crane or trolley.

(c) If resistor enclosures are provided, the enclosures shall be installed to limit exposure to combustible materials.

(d) Conductors connected to resistors shall have a flame-resistant outer covering or be covered with flame-resistant tape.

#### 17-1.14.5 Switches

##### (a) Conductor Disconnecting Means

(1) The power supply to the runway, bridge, or monorail conductors shall be controlled by a switch or circuit breaker located on a fixed structure, accessible from the floor, within view of the conductors, and arranged to be locked in the open position. The switch shall open all ungrounded conductors simultaneously and the means for locking shall remain in place with or without the lock installed.

##### (b) Disconnecting Means for Cranes and Monorail Hoists

(1) A switch or circuit breaker of the enclosed type with a provision for locking in the open position shall be provided in the leads from the runway conductors or other power supply. Means for locking shall remain in place with or without the lock installed.

(2) The disconnecting means required by para. 17-1.14.5(b)(1) may be omitted for monorail hoists and hand-propelled bridge cranes if the installation meets all of the following:

(-a) The monorail hoist or crane is controlled from the ground or floor level.

(-b) The monorail hoist or crane is within view of the power supply disconnecting means.

(-c) No fixed platform has been provided for servicing the crane or monorail hoist.

(3) The disconnecting means required by para. 17-1.14.5(b)(1) may be omitted for equipment when the controls enclosure is mounted remotely from the equipment.

(4) For portable or cord- and plug-connected monorail hoists, the attachment plug suitably horsepower rated per NFPA 70 shall serve as the disconnecting means required by para. 17-1.14.5(b)(1).

(c) *Operation of Disconnecting Means.* One of the following should be provided within reach of the operator when the operator is in the operating position:

(1) a method for opening the disconnecting means in para. 17-1.14.5(b).

(2) a method for opening the disconnecting means in para. 17-1.14.5(a) if the disconnecting means specified in para. 17-1.14.5(b) is not required.

(3) a push button or switch operating a main line contactor. Operation of this device shall set the holding brake(s) and open the power circuit to all motors.

#### 17-1.14.6 Conductors

(a) Conductors of the open type, mounted on the bridge, runway beams, or overhead, shall be so located or guarded that persons cannot inadvertently come into contact with the energized conductors under normal operating conditions or under maintenance procedures as stated in para. 17-4.2.3.

(b) For grounding purposes, a separate grounding conductor shall be provided.

#### 17-1.14.7 Permanently Mounted Magnets

(a) A crane configured with a permanently mounted magnet shall have a separate magnet circuit switch of the enclosed type with provision for locking in the open (OFF) position. The magnet disconnect switch shall be connected on the line side (power supply side) of the crane disconnect switch.

(b) Means shall be provided for discharging the inductive load of a lifting magnet.

(c) Indication or signal lights should be provided to indicate that power to a lifting magnet is ON or OFF. These lights, if used, shall be visible to the crane operator and to persons on the floor.

(d) For a remote-operated crane, the loss of the remote signal shall not result in demagnetizing the lifting magnet.

(e) A minimum of two collectors for each runway conductor shall be furnished when the crane is used with a lifting magnet.

(f) Lifting magnet units shall comply with the provisions of ASME B30.20.

#### 17-1.14.8 Service Receptacle

If a service receptacle is provided in the cab or on the bridge, it shall be a grounded-type permanent receptacle not exceeding 300 V.

### SECTION 17-1.15: HOISTING EQUIPMENT

Hoist units shall comply with the provisions of ASME B30.16.

**17-1.16: WARNING DEVICES****17-1.16.1 Cab- and Remote-Operated Equipment**

- (a) A warning device shall be provided to warn persons in the path of the load.
- (b) Refer to para. 17-3.3.4(b)(23) for operation of the device.

**17-1.16.2 Floor-Operated Equipment**

- (a) A warning device should be provided for installations where the ability of the operator to warn persons in the path of the load is impaired.
- (b) Refer to para. 17-3.3.4(c)(15) for operation of the device.

**17-1.16.3 Types of Warning Devices**

One or more of the following devices shall be provided when required:

- (a) manually operated gong
- (b) power-operated audible signal
- (c) rotating beacon
- (d) strobe light

**SECTION 17-1.17: INSTALLATION**

The installation of the equipment shall be in accordance with the equipment manufacturer's or qualified person's recommendations.

**SECTION 17-1.18: TROLLEYS (CARRIERS)**

- (a) Trolley wheel configuration shall be matched to the track, beam, or rail shape and size (see Fig. 17-1.18-1).
- (b) The trolley shall be suitable to operate on the minimum radius and contour of the beam.
- (c) Refer to the equipment manufacturer, the operating manual, or other technical information from the manufacturer or a qualified person for suitable equipment application.
- (d) Adjust the trolley for proper fit and clearance for the application as referenced in the manual provided with the equipment (see Fig. 17-1.18-2).

**SECTION 17-1.19: MANUAL****17-1.19.1 General Information**

- (a) The crane manufacturer shall furnish with each crane at least one copy of the manual. The manual shall include general information applicable to the following:
- (a) installation
- (b) operation
- (c) inspection
- (d) testing
- (e) lubrication
- (f) maintenance
- (g) parts
- (h) wiring diagram (may be supplied separately)
- (b) Personnel responsible for the supervision, installation, operation, inspection, or maintenance of the crane shall be familiar with the applicable contents of the manual furnished with the crane.

**17-1.19.2 Translation of Manuals**

- (a) Translation of Non-English Documentation Into English
- (1) The wording of written non-English safety information and manuals regarding use, inspection, and maintenance shall be translated into English by professional translation industry standards, which include, but are not limited to, the following:
- (-a) translation of the complete paragraph message, instead of word by word
- (-b) grammatical accuracy
- (-c) respectfulness of the source document content without omitting or expanding the text
- (-d) accurate translation of the terminology
- (-e) reflection of the level of sophistication of the original document
- (2) The finished translation shall be verified for compliance with paras. 17-1.19.2(a)(1)(-a) through (a)(1)(-e) by a qualified person having an understanding of the technical content of the subject matter.
- (3) Pictograms used to identify controls shall be described in the manuals. The pictograms should comply with ISO 7000, ISO 7296, or other recognized source, if previously defined. The text of the description shall meet the criteria of paras. 17-1.19.2(a)(1) and (a)(2).
- (b) Any non-English documentation provided in addition to English shall be translated and reviewed in accordance with the requirements listed above.

Fig. 17-1.14.3-1 Recommended Arrangement of Controllers or Master Switches (Three-Motion Crane)

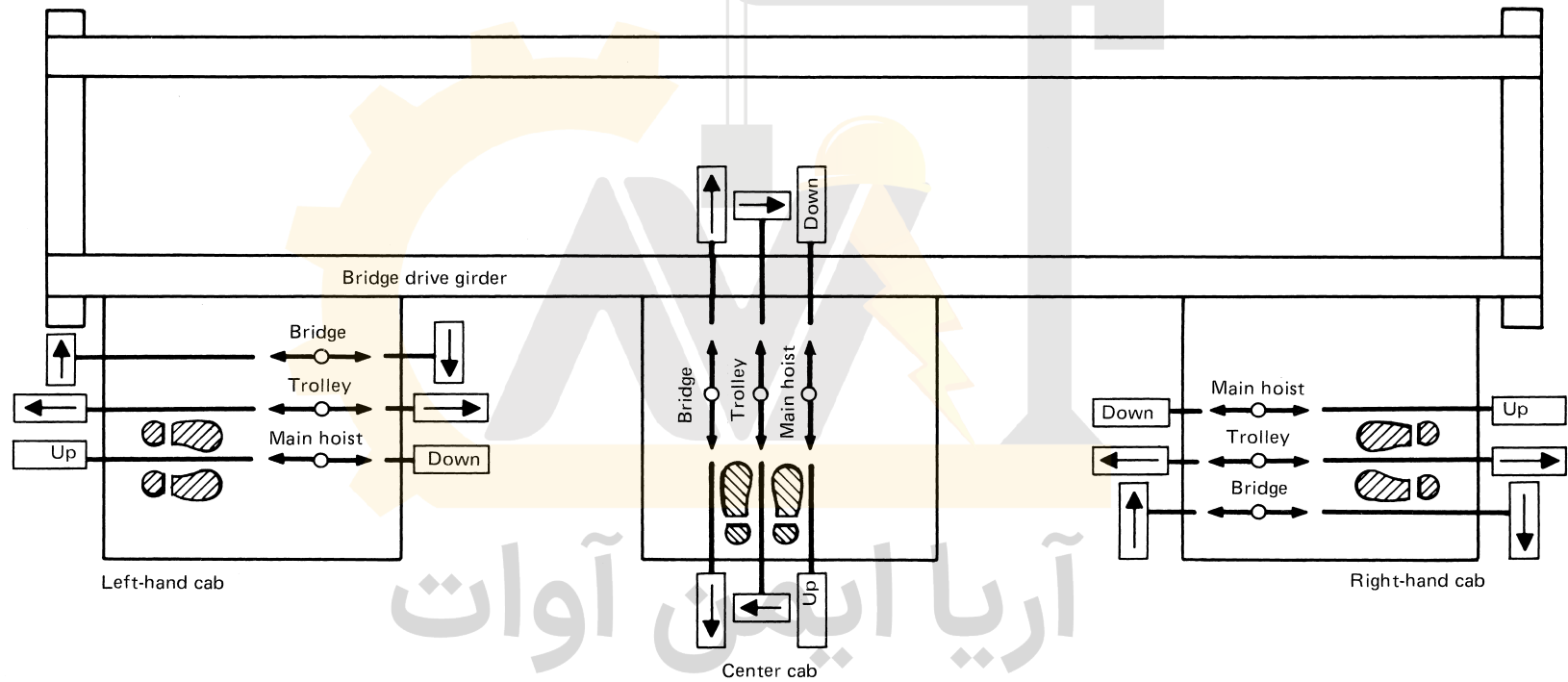
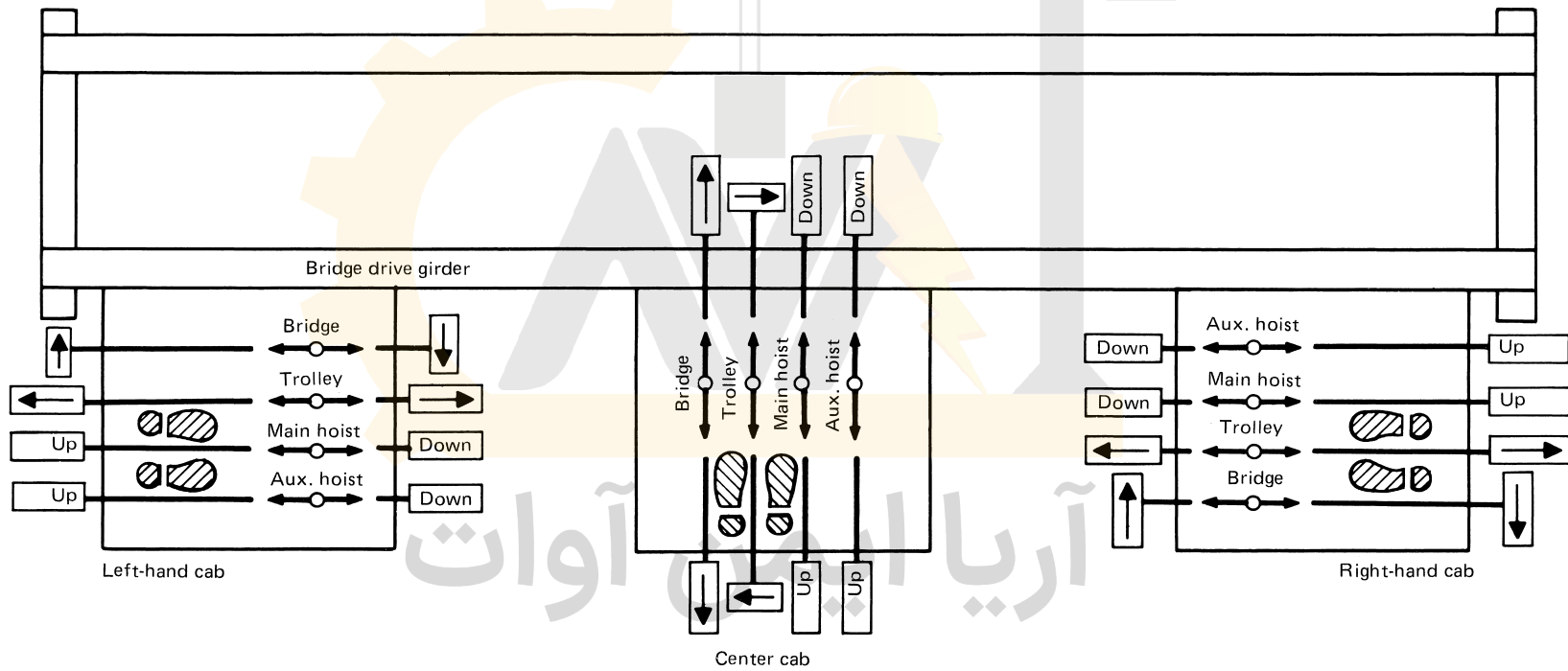
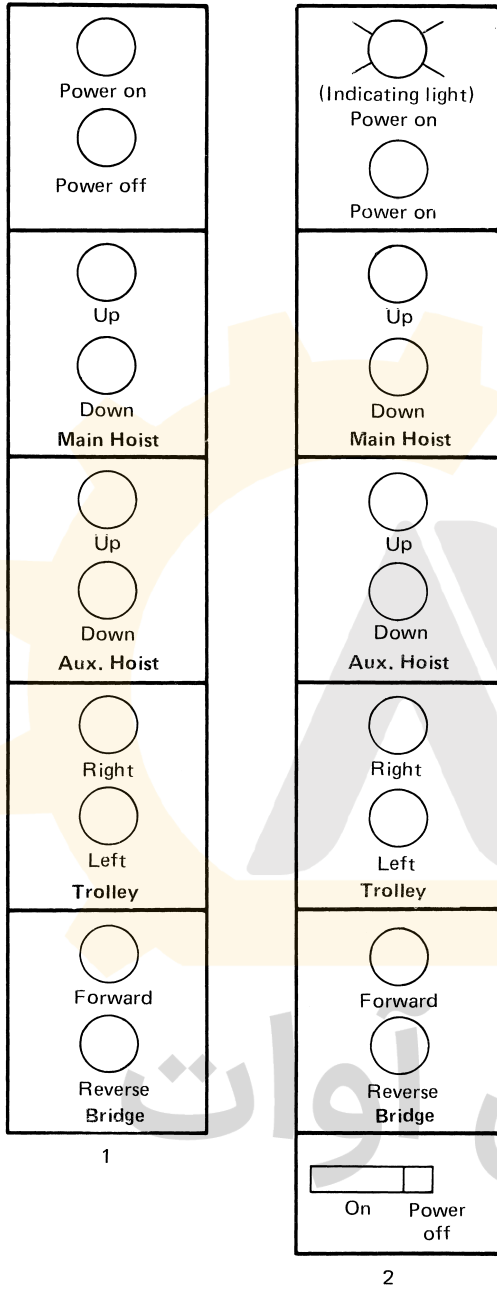

Fig. 17-1.14.3-2 Recommended Arrangement of Controllers or Master Switches (Four-Motion Crane)



**17.4.3-3 Recommended Arrangement of Controllers (Pendant Push-Button Station Arrangements)**



**Fig. 17-1.14.3-4 Recommended Arrangement of Controllers (Radio Crane Control Transmitter Lever Arrangements)**

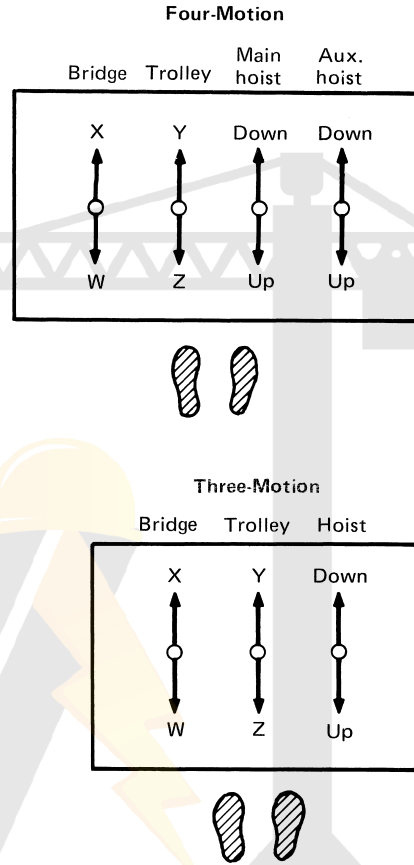

**GENERAL NOTES:**

- (a) Markings on the crane, visible from the floor, shall indicate the direction of bridge and trolley travel corresponding to the W, X, Y, and Z designations on the transmitter.
- (b) The letters used are only intended for the purpose of illustration.
- (c) Designations should be selected as appropriate to each illustration.

GENERAL NOTE: In each user location, the relative arrangement of units on crane pendant push-button stations should be standardized. In the absence of such standardization, arrangements 1 and 2 above are suggested.

Fig. 17-1.18-1 Trolley Wheel Configurations

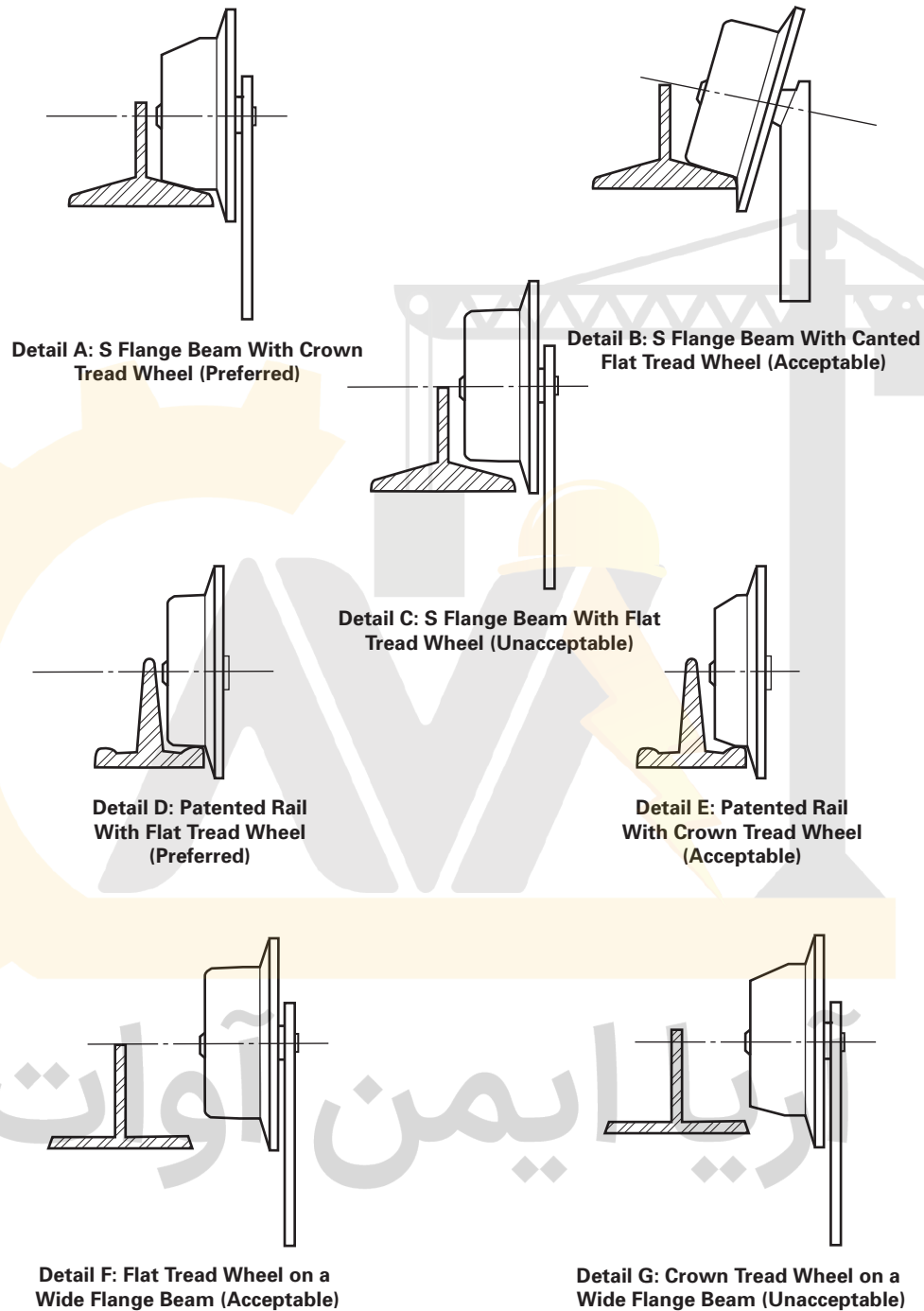
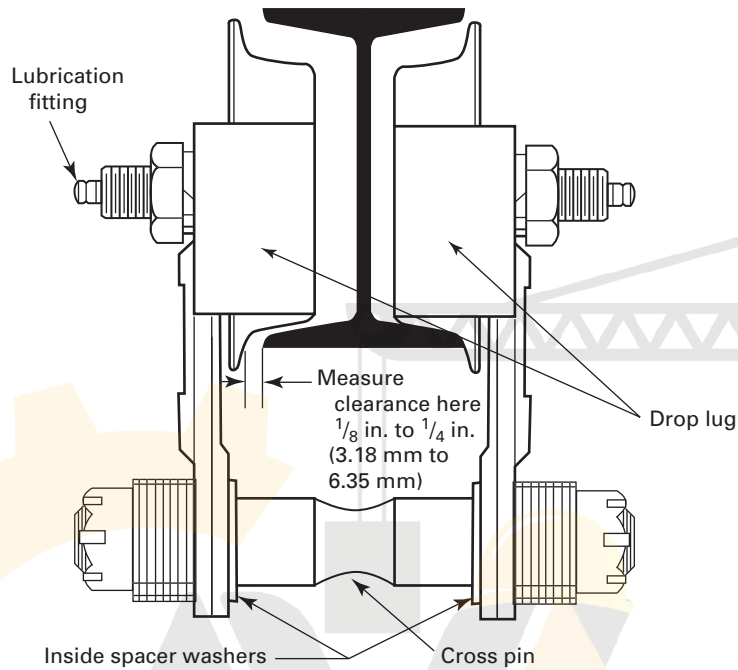



Fig. 17-1.18-2 Recommended Trolley Fit



**Spacer Washer Arrangement  
(Minimum Flange Width Shown)**

GENERAL NOTES:

- To adjust for wider flange widths, use additional washers inside as required. Equal numbers of washers should be used at each of cross pin.
- Gap between drop lugs shall be less than half of the beam width.

## Chapter 17-2 Inspection and Testing

(15)

### SECTION 17-2.1: INSPECTION

#### 17-2.1.1 General

(a) All inspections shall be performed by a designated person in accordance with the manufacturer's recommendations and with the requirements of this Volume. Any deficiencies identified shall be examined and a determination made by a qualified person as to whether they constitute a hazard and whether disassembly or a more detailed inspection is required. Any condition disclosed by these inspections that is determined to be a hazard to continued operation shall be corrected before continuing the use of the equipment.

(b) There are five types of inspections required, each directed toward a different set of circumstances. They are the following:

- (1) initial inspection
- (2) functional test inspection
- (3) frequent inspection
- (4) periodic inspection
- (5) inspection of equipment not in regular use

(c) In addition, the inspection and testing shall be based on the recommendations in the equipment manufacturer's manual and, when appropriate, recommendations by a qualified person based upon review of the equipment application and operation.

#### 17-2.1.2 Initial Inspection

(a) An initial inspection is a visual and audible examination of the equipment.

(b) New, reinstalled, altered, repaired, and modified equipment as defined in the scope of this Volume shall be inspected prior to initial use to verify compliance with applicable provisions of Chapter 17-1 of this Volume.

(c) New, reinstalled, altered, repaired, and modified track sections and their support systems for monorail systems, runways and their support systems for underhung cranes, and runway rails for top running cranes shall be inspected prior to initial use to verify compliance with applicable provisions of Chapter 17-1 of this Volume.

(d) Inspection of altered, repaired, and modified equipment may be limited to the parts of the crane, runway, monorail systems, or support system affected by the alteration, repair, or modification as determined by a qualified person.

(e) The equipment, in addition to the inspection, shall be tested in accordance with Section 17-2.2.

(f) Adjustments, repairs, or replacements necessary to satisfy the requirements of this Section shall be made in accordance with para.17-4.2.4 prior to initial use.

(g) Dated and signed inspection and test records shall be maintained to provide the basis for continuing evaluation. Records should be kept available.

#### 17-2.1.3 Functional Test Inspection

(a) A functional test inspection is a visual and audible operational examination of the equipment, and shall be conducted at the beginning of each shift or before the equipment is first used during each shift. In special applications, when the handling of a suspended load is transferred from operator to operator at shift change, the functional test inspection shall be performed when that lift is completed.

(b) As a minimum, the following items shall be inspected during performance of the functional test inspection:

- (1) operational controls
- (2) upper limit device(s) in accordance with ASME B30.16
- (3) chain or wire rope in accordance with ASME B30.16

(c) Deficiencies discovered during this inspection shall be reported immediately to the supervisor or a designated person.

(d) Adjustments, repairs, or replacements shall be made in accordance with para.17-4.2.4 prior to use.

#### 17-2.1.4 Frequent Inspection

(a) A frequent inspection is a visual and audible examination of the equipment.

(b) Hoist inspection shall be in accordance with ASME B30.16.

(c) Equipment shall be inspected at intervals dependent on the use of the equipment as follows:

- (1) normal service — monthly
- (2) heavy service — weekly to monthly
- (3) severe service — daily to weekly

(d) As a minimum, the following items shall be inspected:

- (1) operating mechanisms for proper operation, proper adjustment, and unusual sounds such as, but not limited to, squeaking, grinding, and grating.
- (2) upper limit device(s) in accordance with ASME B30.16



(4) hoses, valves, pumps, lines, and other parts of hydraulic systems for leakage  
(5) hooks and hook latches, if used in accordance with ASME B30.10

- (5) hook attachment and securing means
- (6) warning device(s) for proper operation
- (7) chain or wire rope in accordance with ASME B30.16

(8) placement of end stops

(e) Adjustments, repairs, or replacements shall be made, as necessary, in accordance with para. 17-4.2.4.

(f) Deficiencies discovered during this inspection shall be reported immediately to the supervisor or a designated person.

#### 17-2.1.5 Periodic Inspection — Crane or Monorail System

(a) A periodic inspection is a visual and audible examination of the equipment.

(b) Covers and other items supplied to allow inspection of components shall be opened or removed.

(c) Hoist inspection shall be in accordance with ASME B30.16.

(d) Equipment shall be inspected at intervals dependent on the use of the equipment as follows:

- (1) normal service — yearly
- (2) heavy service — semiannually
- (3) severe service — quarterly

(e) The inspection shall include the items listed in para. 17-2.1.4(d) and the following items, as applicable:

(1) deformed, cracked, or corroded members including hangers and sway braces.

(2) loose or missing fasteners, such as bolts, nuts, pins, or rivets.

(3) cracked or worn sheaves, drums, or chain sprockets.

(4) worn, cracked, or distorted parts such as pins, bearings, wheels, shafts, gears, or rollers.

(5) excessive wear of brake system parts.

(6) excessive wear of chain drive sprockets and excessive chain stretch.

(7) deterioration of motors, controllers, master switches, contacts, limit device(s), and push-button stations, but not limited to these items.

(8) wind speed indicators for proper operation.

(9) travel limit devices for proper performance.

Each motion shall be inched or operated at low speed into the limit device with no load on the crane.

(10) gasoline, diesel, electric, or other power plants for proper operation.

(11) upper and lower limit device(s) in accordance with ASME B30.16.

(12) function, instruction, warning and safety information signs, labels, or plates for placement and legibility.

(13) excessive wear of drive tires.

(14) excessive wear or deformation of the lower load-carrying flange of all track sections in the system.

(15) rail, runway, monorail, and support systems.

(16) excessive wear of trolley(s) and end truck guide and drive wheels.

(17) trolley adjustments and tolerances to manufacturer specifications.

(18) securing devices such as clips, clamps, j-bolts, and drop protection devices.

(19) worn, cracked, or distorted parts such as locking and clamping devices, bumpers, switch baffles, interlock bolts, and end stops.

(20) indications of improper alignment such as wear or binding, in accordance with manufacturer's recommendations.

(f) Adjustments, repairs, or replacements shall be made, as necessary, in accordance with para. 17-4.2.4.

(g) Dated and signed inspection and test records shall be maintained to provide the basis for continuing evaluation. Records should be kept available.

#### 17-2.1.6 Inspection of Cranes and Monorails Not in Regular Use

(a) Equipment that has been idle for a period of 1 month or more, but less than 1 yr, shall be inspected in accordance with para. 17-2.1.4 before being placed into service.

(b) Equipment that has been idle for a period of 1 yr or more shall be inspected in accordance with para. 17-2.1.5 before being placed into service.

### SECTION 17-2.2: TESTING

#### 17-2.2.1 Operational Tests

(a) New, reinstalled, altered, repaired, and modified cranes and monorail systems shall be tested by a designated person prior to initial use to confirm that the equipment performs in compliance with the provisions of this Volume.

(b) Tests shall include, as applicable, the following functions:

(1) lifting and lowering

(2) trolley travel

(3) bridge travel

(4) hoist(s) in accordance with ASME B30.16

(5) travel-limiting devices

(6) locking and safety devices for interlocking mechanisms, track switches, drop sections, and lift sections

(7) indicating devices, if provided

(c) Operational testing of altered, repaired, or modified crane and monorail systems may be limited to the functions affected by the alteration, repair, or modification as determined by a qualified person.



## Load Test

New, reinstalled, altered, repaired, and modified equipment should be load tested prior to initial use as determined by a qualified person.

(b) Load testing of altered, repaired, and modified equipment may be limited to the functions affected by the alteration, repair, or modification, as determined by a qualified person.

(c) The replacement of load chain and rope is specifically excluded from this load test; however, an operational test of the hoist shall be made in accordance with ASME B30.16 prior to putting the crane or monorail system back in service.

(d) If a load test is conducted, the load shall be not less than 100% nor more than 125% of the rated load of the crane or monorail system, unless otherwise recommended by the manufacturer or a qualified person.

(e) If a load test is conducted, the person conducting the load test shall prepare a written report of the load sustained during the test and the operations performed during the test. Reports shall be placed on file.

(f) If a load test is conducted for cranes, operations shall be performed as outlined below or as modified by a qualified person.

(1) Hoist the test load a distance to ensure that the load is supported by the crane and held by the hoist brake(s).

NOTE: Hoist(s) shall be load tested per ASME B30.16.

(2) Transport the test load by means of the trolley for the full length of the bridge.

(3) Transport the test load by means of the bridge for the full length of the runway in one direction with the trolley as close to the extreme right-hand end of the

crane as practical and in the other direction with the trolley as close to the left-hand end of the crane as practical. When cranes operate on more than two runways (multiple-truck cranes), the crane shall also transport the test load the full length of the runway with the trolley positioned at each intermediate end truck.

(4) Lower the test load, stop, and hold the load with the brake(s).

(g) If a load test is conducted for monorail systems, operations shall be performed as outlined below or as modified by a qualified person.

(1) Hoist the test load a distance to ensure that the load is supported by the equipment and held by the hoist brake(s).

NOTE: Hoist(s) shall be load tested per ASME B30.16.

(2) Transport the test load by means of the trolley for the full length of the monorail system.

(3) Lower the test load, stop, and hold the load with the brake(s).

(h) If a load test is conducted for jib crane systems, operations shall be performed as outlined below or as modified by a qualified person.

(1) Hoist the test load a distance to ensure that the load is supported by the equipment and held by the hoist brake(s).

NOTE: Hoist(s) shall be load tested per ASME B30.16.

(2) Transport the test load by means of the trolley for the full length of the jib system.

(3) Rotate the jib throughout the full range of travel with the test load applied at the maximum distance from the pivot point.

(4) Lower the test load, stop, and hold the load with the brake(s).

آریا ایمن آوات



## Chapter 17-3 Operator Training and Operation

### SECTION 17-3.1: OPERATOR TRAINING

#### 17-3.1.1 Purpose of Operator Training

Operator training shall be provided to promote proficient performance of the operator in conformance with the manufacturer's instructions and provisions of this Volume.

#### 17-3.1.2 Operator Training – General

(a) Training shall include those items that apply to the equipment and the particular application of the crane or monorail system. Refer to para. 17-3.1.3 as a guide for sources of training material.

(b) Training programs and their contents shall be based upon, but not limited to, the following:

- (1) physical characteristics of the workplace
- (2) performance characteristics and complexity of the equipment
- (3) types of load to be handled
- (4) responsibilities of the crane or monorail system operator and other persons involved in the movement of the load (see paras. 17-3.3.2 and 17-3.3.4)

(c) Trainees under the supervision of a designated person, the number of trainees permitted to be supervised by a single designated person, the physical location of the designated person while supervising, and the type of communication required between the designated person and the trainee shall be determined by a qualified person.

#### 17-3.1.3 Sources of Training Material

Examples of sources of training material are as follows:

- (a) information outlined in the manual provided with the equipment
- (b) information available through trade associations
- (c) government training resources such as the Department of Labor
- (d) organized labor groups
- (e) courses, seminars, and literature offered by manufacturers of cranes and monorail systems, consultants, trade schools, continuing education schools, employers, and manufacturers of crane and monorail system component parts
- (f) requirements and recommendations found in national consensus standards such as this Volume

### SECTION 17-3.2: TRAINING FOR PERSONS OTHER THAN CRANE AND MONORAIL SYSTEM OPERATORS

Other persons, such as, but not limited to, maintenance personnel, test personnel, and inspectors, shall be trained in accordance with the training requirements of this Volume when it is necessary to operate a crane or monorail system in the performance of their duties.

### SECTION 17-3.3: OPERATION

#### 17-3.3.1 Scope of Crane and Monorail Systems Operations

The operation of cranes and monorail systems shall be in accordance with the provisions included in this Volume and in manuals furnished by the equipment manufacturer. The requirements of an operator of a crane or monorail system apply to both dedicated and non-dedicated operators.

#### 17-3.3.2 General Requirements to Be Followed During Equipment Operation

All personnel involved with the crane or monorail system operation shall comply with the following:

- (a) equipment lockout/tagout procedures (see Section 17-3.7).
- (b) warnings, signs, labels, plates, or tags.
- (c) the crane or monorail system shall not be used to lift, lower, or travel while anyone is on the load or hook.
- (d) the hoist chain or rope shall be free from kinks or twists and shall not be wrapped around the load.
- (e) a hook latch shall be used when provided.
- (f) the hook latch (when provided) shall be closed and shall not be used to support any part of the load.
- (g) the load, sling, or lifting device shall be seated in the bowl of the hook.
- (h) the hoist chain(s) or rope(s) shall be seated in its chain sprockets or drum and sheave grooves.
- (i) persons shall stay clear of a suspended load.
- (j) caution shall be exercised when using a crane having a lifting magnet, due to hazards of falling metal.
- (k) equipment shall be used to lift loads vertically without side pull, except when specifically authorized by the manufacturer(s) or a qualified person who have determined that
  - (1) the various parts of the crane will not be overstressed



the stability of the crane is not thereby  
ered

(3) such side pulls will not cause the hoist rope to be pulled out of the sheaves or across drum grooves

(4) such side pulls will not result in excessive swinging of the load block or load, or damage to the chain hoist

(l) the crane or monorail system shall not be used to lift loads in excess of the rated load of the system except during load tests or planned engineered lifts in accordance with Section 17-3.4.

(m) when multiple hoists, trolleys, bridges, or other devices are installed, the total load shall not exceed the capacity of the system nor shall any individual component be loaded in excess of its rated load.

(n) a load-limiting device shall not be used to measure the weight of the load.

(o) the hoist rope shall be protected so far as is practical from weld spatter or other damaging contaminants.

(p) when two or more pieces of equipment are used to lift a single load, one designated person shall be in charge of the operation. This person shall analyze the operation and instruct all personnel involved in the proper positioning and rigging of the load and the movements to be made.

(q) no one, other than the operator, shall enter a crane cab or pulpit, with the exception of persons such as oilers and supervisors whose duties require them to do so, and then only in the performance of their duties and with the knowledge of the operator.

### 17-3.3.3 Responsibilities of Management (Owners/ Users)

Management (owners/users) shall

(a) identify, document, and assign responsibilities of the equipment operator and other persons involved in the movement of the load(s) (see paras. 17-3.3.2 and 17-3.3.4).

(b) provide or verify that persons who will operate the equipment have been trained.

(c) provide a written and practical examination that verifies that the person has acquired the knowledge and skill to operate the specific type of equipment that will be operated. The examinations shall be defined by the owner/user and in accordance with any local, state, and federal provisions that may apply.

(d) issue a certificate or formal record that verifies the person has been trained and has passed the examination required in para. 17-3.3.3(c), or confirm the person has a valid certificate or formal record that satisfies the requirements of para. 17-3.3.3(c).

### 17-3.3.4 Responsibilities of Operators

(a) Lifting and moving the load

(1) The following three phases of lifting and moving the load shall be addressed:

(-a) before the lift

(-b) during the lift

(-c) after the lift

(2) Rigging the load, attaching the load to the hook, and other tasks related to moving the load may be performed by persons other than the equipment operator.

(3) Equipment operation may require the use of a signalperson or other personnel who have responsibility for directing the lift and move functions. This signalperson or personnel shall be assigned prior to the lift.

(b) Before the lift, operators shall

(1) be familiar with the equipment safety procedures and instructions listed in manual(s) provided with the equipment

(2) be familiar with controls, instructions, and warnings located on the lifting equipment

(3) operate the equipment only when physically and otherwise fit

(4) not energize any switch that controls power to the crane or monorail system, such as, but not limited to, the equipment disconnect, motion disconnect, or runway disconnect, if a warning sign, lock, or tag is on the device until the sign, lock, or tag is removed by the person who placed it on the device or by an authorized person

(5) not remove a warning sign, lock, or tag that is on any switch that controls power to the crane, such as, but not limited to, the equipment disconnect, motion disconnect, or runway disconnect, if the sign, lock, or tag was placed on the device by another person

(6) place all controllers in the OFF position before energizing the crane or monorail system

(7) verify that no worker is on or adjacent to the equipment in a hazardous location potentially caused by energizing the crane or monorail system

(8) perform a functional test inspection in accordance with para. 17-2.1.3

(9) not remove or obscure the warning, labels, plates, or tags furnished on the lifting equipment

(10) be familiar with and understand hand signals (see Section 17-3.5 and Fig. 17-3.5.3-1)

(11) verify that the hook, bridge, and trolley travel in the same direction as shown on the controls

(12) verify that chains or wire ropes are not kinked or twisted, or that multiple-part chain or wire ropes are not twisted about each other

(13) verify that the hoist chain or wire rope is not wrapped around the load

(14) attach the load to the hook or have the load attached to the hook by means of slings or other lifting devices

(15) verify that the load, sling, or lifting device is seated in the bowl of the hook

(16) use a hook latch when provided

(17) verify that the hook latch (when provided) is closed and not supporting any part of the load



fy that the hoist load chain or rope is seated in the sockets or drum grooves and in the sheave(s) or grooves if there is or has been a slack rope condition

(19) board or leave the crane (cab) only at authorized locations and designated boarding entrances

(20) verify that the transmitter selected is the correct transmitter for the crane to be operated

(21) verify that the hoist unit is centered over the load's center of gravity, except when authorized by a qualified person [see para. 17-3.3.2(k)]

(22) verify that the weight of the total load to be lifted does not exceed the rated load of the crane or monorail system, or the rigging [see para. 17-3.3.2(l)]

(23) activate the warning device when a device is furnished, before starting the bridge or trolley motion of the crane

(c) During the lift, operators shall

(1) respond to signals from the person directing the lift or a designated signalperson.

(2) be responsible for the lift when a signalperson is not used.

(3) obey any stop signal regardless of who gives it.

(4) verify multiple-part chains or ropes are not twisted around each other when the lift is made.

(5) take up slack load chain or rope carefully, and lift the load a few inches (centimeters) to check the hoist operation and verify that the load is secured, balanced, and positioned on the hook and in the sling or lifting device.

(6) minimize swinging the load or load hook.

(7) maintain firm footing when operating lifting equipment.

(8) avoid sudden acceleration and deceleration of the load.

(9) use the crane or monorail system to lift vertically, without side pull, except when specifically authorized by a qualified person [see para. 17-3.3.2(k)].

(10) verify that the load and rigging are free to move and will clear all obstructions.

(11) check the hoist brake(s) if a load approaching the rated load is to be handled, by lifting the load a few inches (centimeters) and applying the brake(s).

(12) stop the lifting of the load before the upper limit device is engaged. The hoist limit device that controls the upper limit of travel of the load block shall not be used as an operating control in normal operation unless additional means are provided to prevent damage from overtravel.

(13) avoid carrying loads over people.

(14) concentrate on operating the equipment and not allow attention to be diverted while operating the equipment.

(15) activate the warning device intermittently when a device is furnished during travel of the crane when approaching persons in the path of the load.

(16) promptly report to the person responsible for the crane, any malfunction, unusual performance or sound, or damage of equipment.

(17) contact stops, other cranes, or trolleys with caution for the safety of persons on or below the equipment.

(18) place all controllers and master switches in the OFF or neutral position when power is interrupted during operation.

(19) check the controllers for correct direction of motion when power is restored after a power outage.

(20) follow the directions of the designated person in charge of the operation when two or more pieces of equipment are used to lift a single load.

(21) not leave a suspended load unattended, unless provisions have been made to provide auxiliary supporting means under the suspended load, or guards or barriers are utilized on the floor to prevent people from entering the area affected by the suspended load.

(22) not lower the load below the point where two wraps of rope remain on each anchorage of the hoisting drum unless a lower-limit device is provided, in which case, no less than one wrap shall remain.

(23) stop the lowering of the load before the lower limit device is engaged, when furnished, and not use it as an operating control in normal operation.

(24) properly secure an outdoor crane when the wind indicating alarm is activated.

(25) shut off the controller when a power failure occurs.

(26) stop the crane or monorail system functions in a controlled manner when the operator has doubt as to the safety of the crane or monorail system's operations. Lift operations shall resume only after safety concerns have been addressed.

(d) After the lift, operators shall

(1) lift the load block above the highest movable obstruction under the equipment when the equipment is not in use

(2) notify the next operator of adjustment, repair, or replacement that needs to be made

(3) properly secure an outdoor crane or monorail system when shutting down

(4) place the controllers in the OFF or neutral position before leaving the controls of the equipment

(5) shut off the power to cranes or monorail systems before leaving the area

(6) not use the crane or monorail system to remove slings from under a landed load

#### SECTION 17-3.4: PLANNED ENGINEERED LIFTS

Lifts in excess of the rated load may be required from time to time on a limited basis for specific purposes such as new construction or major repairs. Every planned engineered lift exceeding the rated load shall be treated



... and separate event. Limitations and planned provisions shall be applicable as follows:

(a) Hoist(s) used to perform planned engineered lifts shall be powered.

(b) When planned engineered lifts are made, the load shall not exceed 125% of the equipment load rating, except as provided in para. 17-3.4(c).

(c) Planned engineered lifts shall be limited to two occurrences on any crane or monorail system within any continuous 12-month period, except as provided in para. 17-3.4(d). If greater lift frequency is desired, consideration shall be given to rerating or replacing the equipment.

(d) The equipment manufacturer shall be consulted if the planned engineered lift exceeds 125% of rated load or if the frequency of planned engineered lifts exceeds two during a continuous 12-month period.

(e) Each planned engineered lift shall comply with the following requirements:

(1) A written review of the equipment service history shall be prepared, including reference to previous planned engineered lifts, structural repairs, and modifications of original design.

(2) The design of the structural, mechanical, electrical, pneumatic, and hydraulic components of the equipment shall be reviewed by means of applicable calculations for the load to be lifted and approved by the equipment manufacturer or a qualified person according to accepted crane and monorail system design standards.

(3) The design of the equipment's supporting structure shall be reviewed and approved by a qualified person for conformance to applicable design criteria. The supporting structure shall be inspected, and any deterioration or damage shall be taken into consideration in design calculations for the load to be lifted.

(4) The equipment shall be inspected in accordance with para. 17-2.1.5 just prior to making the lift.

(5) The lift shall be made under controlled conditions under the direction of a designated person in accordance with a previously prepared lift plan. All persons in the area of the equipment shall be alerted that the lift is being made.

(6) The operator shall test the equipment at the planned engineered load by lifting the load a few inches (centimeters) and setting the brakes. The lift shall only be continued if the brake stops and holds the load. Any failure to hold the load shall be corrected before proceeding with the lift.

(7) The equipment shall be inspected in accordance with para. 17-2.1.5 after the lift is completed and prior to being used for the lifting of any other load.

(8) A record of the planned engineered lift, including calculations, inspections, and all distances moved, shall be maintained.

(f) The load test specified in para. 17-2.2.2 is not applicable to planned engineered lift provisions.

## SECTION 17-3.5: SIGNALS

### 17-3.5.1 Signaller Qualifications

Prior to signaling crane or monorail systems operations, signalpersons shall be tested by a designated person and demonstrate their qualifications in the following areas:

(a) basic understanding of crane or monorail systems operation and limitations

(b) standard hand signals described in para. 17-3.5.3 whenever hand signals are used

(c) standard voice signals described in para. 17-3.5.4 whenever voice signals are used

### 17-3.5.2 General Instructions

(a) When the need for using signals exists, communication between the operator and the signalperson shall be maintained continuously during all equipment movements. If at any time communication is disrupted, the operator shall stop all equipment movements until communication is restored and a proper signal is given and understood.

(b) If the operator has any concerns regarding the requested movement of the equipment or needs to communicate with the signalperson, the operator shall stop all equipment movement. Equipment movement shall not resume until the operator and the signalperson agree the issue at hand has been resolved.

(c) If it is desired to give instructions to the operator other than those provided by the established signal system, equipment movements shall be stopped.

### 17-3.5.3 Hand Signals

When hand signals are used, they should be posted conspicuously and should be as illustrated in Fig. 17-3.5.3-1.

### 17-3.5.4 Standard Voice Signals

Prior to beginning lifting operations using voice signals, the signals shall be discussed and agreed upon by the person directing lifting operations, the operator, and the appointed signalperson.

(a) Telephones, radios, or equivalent, if used, shall be tested before lifting operations begin. If the system is battery powered, extra batteries should be available at the job site.

(b) Prior to commencing a lift, the operator and signalperson shall contact and identify each other.

(c) All directions given to the operator by the signalperson shall be given from the operator's direction perspective (e.g., travel forward).

(d) Each series of voice signals shall contain three elements stated in the following order:

(1) function and direction





... nce and/or speed  
... ction stop

The following are some examples of signals:

- (a) Travel north 50 ft, 25 ft, 15 ft, 10 ft, 5 ft, 2 ft, travel stop
- (b) Load down 100 ft, 50 ft, 40 ft, 30 ft, . . . 2 ft, load stop
- (c) Load up slow, slow, slow, load stop

For lifting operations using voice signals, the person directing lifting operations shall consider the complexity of the lift, the capabilities of the particular crane, the experience and skill of the operator and signalperson, and the ability to communicate the necessary signals before permitting multiple simultaneous crane function signals.

#### 17-3.5.5 Special Signals

For cranes with separately operated hoists, special operations, or crane attachments not covered by para. 17-3.5.3 or 17-3.5.4, additions to or modifications of the standard signal procedures may be required. In all such cases, the required special signals shall be agreed upon in advance by the crane operator and the signalperson. These special signals should not be in conflict with the standard signals.

### SECTION 17-3.6: MISCELLANEOUS

#### 17-3.6.1 Cabs

- (a) Personal belongings shall be stored in such a manner as to not interfere with access or operation.
- (b) Tools, oil cans, rags, and other necessary articles shall be stored in a fire-resistant container and shall not be permitted to lie loose in or about the cab.
- (c) Materials stored in cabs shall be limited to necessary items.

#### 17-3.6.2 Fire Extinguishers

Operators shall be familiar with the location, operation, and care of fire extinguishers provided (see para. 17-1.6.5).

#### 17-3.6.3 Ladders

- (a) Hands shall be free from encumbrances while personnel are using ladders.
- (b) Articles too large to be carried in pockets or tool belts shall be lifted and lowered by hand line.

### SECTION 17-3.7: EQUIPMENT LOCKOUT/TAGOUT

- (a) A lockout/tagout policy and procedure shall be developed, documented, and implemented by the owner or user of crane and monorail systems.
- (b) The lockout/tagout policy and procedure shall comply with the requirements of ASSE Z244.1.
- (c) The policy shall include, but not be limited to, the following:
  - (1) single-crane runways
  - (2) multiple-crane runways
  - (3) monorail systems
  - (4) cranes on an adjacent runway
  - (5) runway disconnecting means
  - (6) crane disconnecting means
  - (7) work to be done on the crane
  - (8) work to be done other than on a crane, but within the path of a crane where its movement creates a hazard

آریا ایمن آوات

Fig. 17-3.5.3-1 Standard Hand Signals for Cranes and Monorails

<p><b>HOIST</b> With forearm vertical, forefinger pointing up, move hand in small horizontal circle.</p>	<p><b>LOWER</b> With arm extended downward, forefinger pointing down, move hand in small horizontal circles.</p>	<p><b>BRIDGE TRAVEL</b> Arm extended forward, hand open and slightly raised, make pushing motion in direction of travel.</p>
<p><b>TROLLEY TRAVEL</b> Palm up, fingers closed, thumb pointing in direction of motion, jerk hand horizontally.</p>	<p><b>STOP</b> Arm extended, palm down, move arm back and forth.</p>	<p><b>EMERGENCY STOP</b> Both arms extended, palms down, move arms back and forth.</p>
<p><b>MULTIPLE TROLLEYS</b> Hold up one finger for block marked "1" and two fingers for block marked "2." Regular signals follow.</p>	<p><b>MOVE SLOWLY</b> Use one hand to give any motion signal and place other hand motionless in front of hand giving the motion signal. (Hoist slowly shown as example.)</p>	<p><b>MAGNET IS DISCONNECTED</b> Crane operator spreads both hands apart, palms up.</p>



## Chapter 17-4

# Maintenance Training and Maintenance

### SECTION 17-4.1: MAINTENANCE TRAINING

#### 17-4.1.1 Purpose of Maintenance Training

Maintenance training shall be provided to promote knowledge and skill in adjustments, repairs, and replacements on crane and monorail systems that will allow the equipment to perform in accordance with the manufacturer's specification and the provisions of this Volume.

#### 17-4.1.2 Crane and Monorail Systems Maintenance Training — General

This Volume recognizes that crane and monorail systems are used for many different purposes, handling many different kinds of loads in a variety of workplaces, and are maintained in a manner relative to these purposes, kinds of loads, and workplaces. Nevertheless, the requirements for crane and monorail system maintenance training apply to all persons who maintain the mechanical, pneumatic, hydraulic, structural, and electrical components of the equipment.

#### 17-4.1.3 Sources of Training

Examples of sources of maintenance training material are as follows:

- (a) information outlined in the manual(s) provided by the equipment manufacturer
- (b) information available through trade associations
- (c) government training resources such as the Department of Labor
- (d) organized labor groups
- (e) courses, seminars, and literature offered by manufacturers of cranes and monorail systems, consultants, trade schools, continuing education schools, employers, and manufacturers of crane and monorail system component parts
- (f) requirements and recommendations found in national consensus standards such as this Volume

#### 17-4.1.4 Responsibilities of Maintenance Persons

Responsibilities of crane and monorail systems maintenance persons, as applicable, shall include, but not be limited to, the following items:

- (a) Read the applicable equipment safety standard referenced and the instructions outlined in the manual(s) provided for the equipment by the equipment manufacturer.

- (b) Board a crane only at authorized locations and designated boarding entrances.

- (c) Do not board a crane without the knowledge of the operator.

- (d) Do not attempt to repair electrical apparatus or to make other major repairs on the equipment unless specific authorization has been received and the power is locked out/tagged out.

- (e) Lower the load block to the ground or otherwise secure the load block before attempting any repairs or adjustments on the lifting equipment that would allow the load block to lower.

- (f) Use replacement parts that are at least equal to the original manufacturer's specifications.

- (g) Become familiar with wire rope and chain replacement criteria.

- (h) Install wire rope clamps and clips correctly. Refer to the manual provided with the equipment.

- (i) Do not use the wire rope, load chain, or hook as a ground for welding.

- (j) Do not touch a live electrode to the wire rope, load chain, or hook.

- (k) Do not attempt to repair a damaged wire rope or load chain.

- (l) Do not remove or obscure the warning or safety labels, plates, or tags furnished on the lifting equipment.

- (m) Replace safety labels, plates, or tags when they are obscured or illegible.

- (n) Replace all protective guards and panels before returning the crane to normal operation.

- (o) Apply lubricant to the wire rope or load chain as recommended by the hoist, wire rope, or chain manufacturer.

### SECTION 17-4.2: EQUIPMENT MAINTENANCE

#### 17-4.2.1 General Maintenance

General maintenance should be performed in accordance with the requirements of this Volume and the conditions and practices of a particular workplace. The following are some of the factors that influence how maintenance is performed:

- (a) whether there are trained and experienced in-house maintenance persons such as mechanics or millwrights and electricians who can perform maintenance work on cranes and monorail systems



whether an outside crane and monorail service company is contracted to do inspections, perform preventive maintenance, repairs, and replacements

- (c) size of workplace and number of employees
- (d) whether the equipment has sophisticated performance characteristics such as reactor or adjustable frequency controls or basic single-speed or two-speed control systems
- (e) the recommendations in the equipment manufacturer's manual and when appropriate, recommendations by a qualified person based upon review of the equipment application and operation

#### 17-4.2.2 Preventive Maintenance

A preventive maintenance program shall be established. The preventive maintenance program should be based on the equipment manufacturer's recommendations and when appropriate, recommendations by a qualified person based upon review of the equipment application and operation. Dated records should be placed on file.

#### 17-4.2.3 Maintenance Procedure

(a) The following precautions shall be taken before performing maintenance on a crane or monorail system:

- (1) The crane or monorail trolley shall be moved to a location where it will cause the least interference with other cranes or trolleys on the system and operations in the area.
- (2) If a load is attached to the crane or monorail system, it shall be landed.
- (3) All controllers shall be placed in the OFF or neutral position.
- (4) If the hoist is suspended from a trolley, provisions should be taken to prevent movement of the trolley.
- (5) A lockout/tagout procedure shall be performed (see Section 17-3.7).
- (6) Warning signs and barriers shall be used on the floor beneath the crane where overhead maintenance work creates a hazard.
- (7) Warning signs and barriers, when used, shall be placed and removed only by designated persons.
- (8) Where other equipment or trolleys are in operation on the same runways or monorail track, rail stops, signalperson(s) located full-time at a visual vantage point for observing the approach of an active crane(s), or other means shall be provided to prevent interference with the idle equipment.
- (9) A guard or barrier shall be installed between adjacent runways for the length of the established work area to prevent contact between persons performing maintenance and a crane on the adjacent runway.
- (10) Crane travel shall be prohibited or restricted while a person is on a service platform and the overhead clearance is less than 78 in. (1 980 mm) at any location in the path of the crane.

(b) The following precautions shall be taken before performing maintenance on a crane runway, monorail, support system, power distribution system, or the areas of the building in the path of travel of the crane bridge or trolley:

- (1) A lockout/tagout procedure shall be performed (see Section 17-3.7).
- (2) Warning signs and barriers shall be utilized on the floor beneath the area where overhead maintenance work creates a hazard.
- (3) If the runway remains energized, rail stops or a signalperson(s), located full-time at a visual vantage point for observing the approach of an active crane(s), shall be provided to prohibit contact by the active crane(s) with any idle crane, with persons performing maintenance, and with equipment used in performing the maintenance.
- (4) A guard or barrier shall be installed between adjacent runways for the length of any established work area to prevent contact between persons performing maintenance and a crane on the adjacent runway.

(c) Only designated persons shall work on energized equipment.

(d) After maintenance work is completed and before restoring the equipment to normal operation

- (1) equipment guards shall be reinstalled
- (2) safety devices shall be reactivated
- (3) replaced parts and loose material shall be removed
- (4) maintenance equipment, including barriers, shall be removed

#### 17-4.2.4 Adjustments, Repairs, and Replacements

(a) Any condition disclosed by the inspections performed in accordance with Section 17-2.1 that is determined to be a hazard to continued operation shall be corrected by adjustment, repair, or replacement before continuing the use of the equipment.

(b) Adjustments, repairs, and replacements shall be performed by designated personnel.

(c) Components shall be adjusted or repaired as needed. The following are examples:

- (1) hoists as described under "Adjustments and Replacements" in ASME B30.16
- (2) operating mechanisms
- (3) interlocks, crossovers, track switches, and track openers
- (4) limit devices
- (5) control systems
- (6) brakes

(d) Repairs or replacements shall be made as needed. The following are examples:

- (1) hoists as described under "Adjustments and Replacements" in ASME B30.16



aged or worn hooks as described under "Hooks" in ASME B30.10 (repairs by welding or brazing are not recommended)

(3) critical parts that are cracked, broken, bent, excessively worn, or missing

(4) pitted or burned electrical contacts in sets only

(5) function labels on pendant control stations and master switches that are illegible

(e) Identification of materials shall be made and appropriate welding procedures shall be followed when repairs to load-sustaining members are made by welding.

(f) Dated records should be placed on file.

#### 17-4.2.5 Lubrication

(a) Moving parts of the crane or monorail system for which lubrication is specified, including hoist mechanisms and other ropes and chains, should be lubricated

regularly. Both manual and remote lubrication systems should be checked for proper delivery of the lubricant. Care should be taken to follow the manufacturer's recommendations as to points and frequency of lubrication, maintenance of lubricant levels, and types of lubricant to be used.

(b) Cranes or trolleys shall be stationary while lubricants are being applied, and protection shall be provided as called for in paras. 17-4.2.3(a)(1) through 17-4.2.3(a)(5), unless the cranes or trolleys are equipped for automatic or remote lubrication.

#### 17-4.2.6 Chain and Wire Rope Inspection, Replacement, and Maintenance

Chain and rope inspection, replacement, and maintenance shall be per ASME B30.16.

آریا ایمن آوات



## ASME B30.17 INTERPRETATIONS

### Reply to Technical Inquiry June 2009

#### FOREWORD

This publication includes all of the written replies issued between the indicated dates by the Secretary, speaking for the ASME B30 Committee, Safety Standard for Cableways, Cranes, Derricks, Hoists, Hooks, Jacks, and Slings, to inquiries concerning interpretations of technical aspects of ASME B30.17, Overhead and Gantry Cranes (Top Running Bridge, Single Girder, Underhung Hoist).

These replies are taken verbatim from the original letters, except for a few typographical corrections and some minor editorial corrections made for the purpose of improved clarity. In some few instances, a review of the interpretations reveals a need for corrections of a technical nature; in these cases, a corrected interpretation immediately follows the original reply.

These interpretations were prepared in accordance with accredited ASME procedures. ASME procedures provide for reconsideration of these interpretations when or if additional information is available which the inquirer believes might affect the interpretation. Further, persons aggrieved by this interpretation may appeal to the cognizant ASME Committee or Subcommittee. ASME does not "approve," "certify," "rate," or "endorse" any item, construction, proprietary device, or activity.

آریا ایمن آوات



interpretation: 17-4

Subject: ASME B30.17-2006, Paragraph 17-1.1.5

Date Issued: June 29, 2009

Question: Do warning labels apply to receiver control boxes?

Reply: Yes; see para. 17-1.1.5(c).

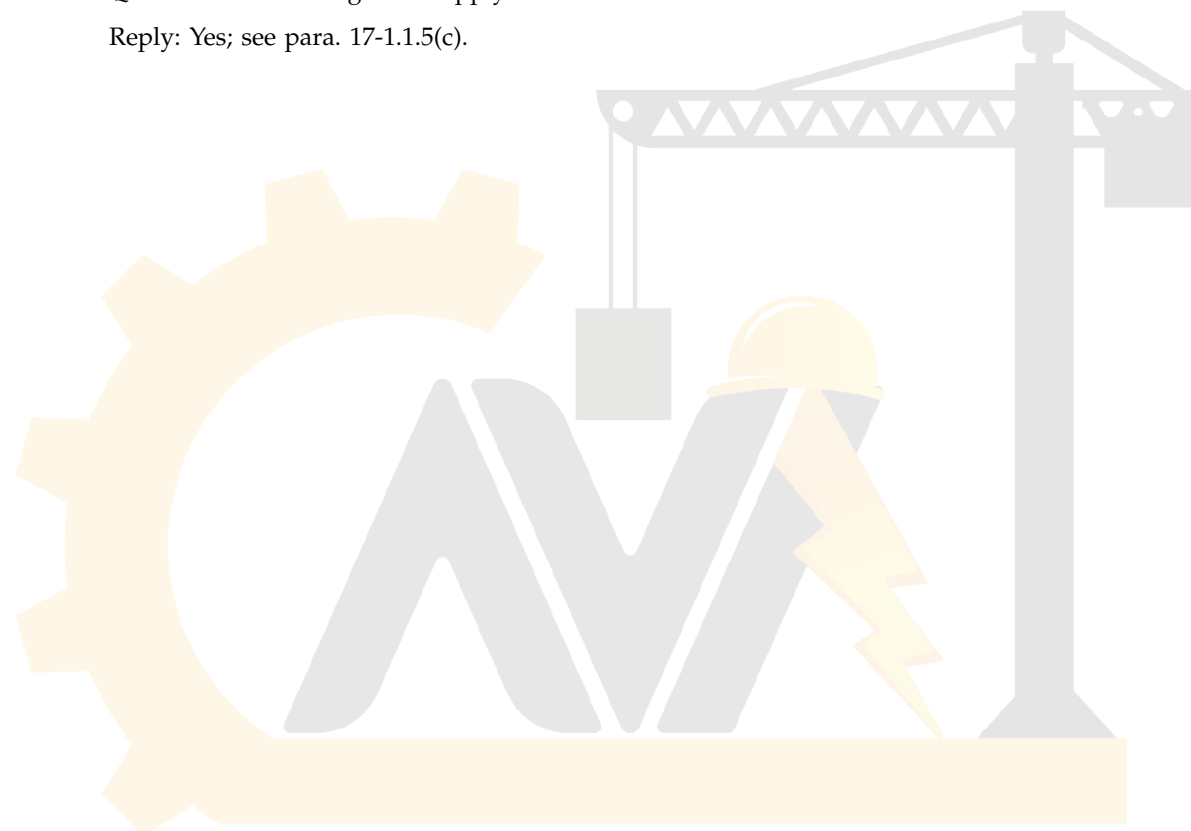

آریا ایمن آوات



## ASME Services

ASME is committed to developing and delivering technical information. At ASME's Customer Care, we make every effort to answer your questions and expedite your orders. Our representatives are ready to assist you in the following areas:

ASME Press  
Codes & Standards  
Credit Card Orders  
IMechE Publications  
Meetings & Conferences  
Member Dues Status

Member Services & Benefits  
Other ASME Programs  
Payment Inquiries  
Professional Development  
Short Courses  
Publications

Public Information  
Self-Study Courses  
Shipping Information  
Subscriptions/Journals/Magazines  
Symposia Volumes  
Technical Papers

### How can you reach us? It's easier than ever!

There are four options for making inquiries\* or placing orders. Simply mail, phone, fax, or E-mail us and a Customer Care representative will handle your request.

**Mail**  
**ASME**  
150 Clove Road, 6th Floor  
Little Falls, New Jersey  
07424-2138

**Call Toll Free**  
**US & Canada:** 800-THE-ASME  
(800-843-2763)  
**Mexico:** 95-800-THE-ASME  
(95-800-843-2763)

**Fax—24 hours**  
973-882-1717  
973-882-5155

**E-Mail—24 hours**  
customercare@asme.org

# آریا ایمن آوات

\* Customer Care staff are not permitted to answer inquiries about the technical content of this code or standard. Information as to whether or not technical inquiries are issued to this code or standard is shown on the copyright page. All technical inquiries must be submitted in writing to the staff secretary. Additional procedures for inquiries may be listed within.



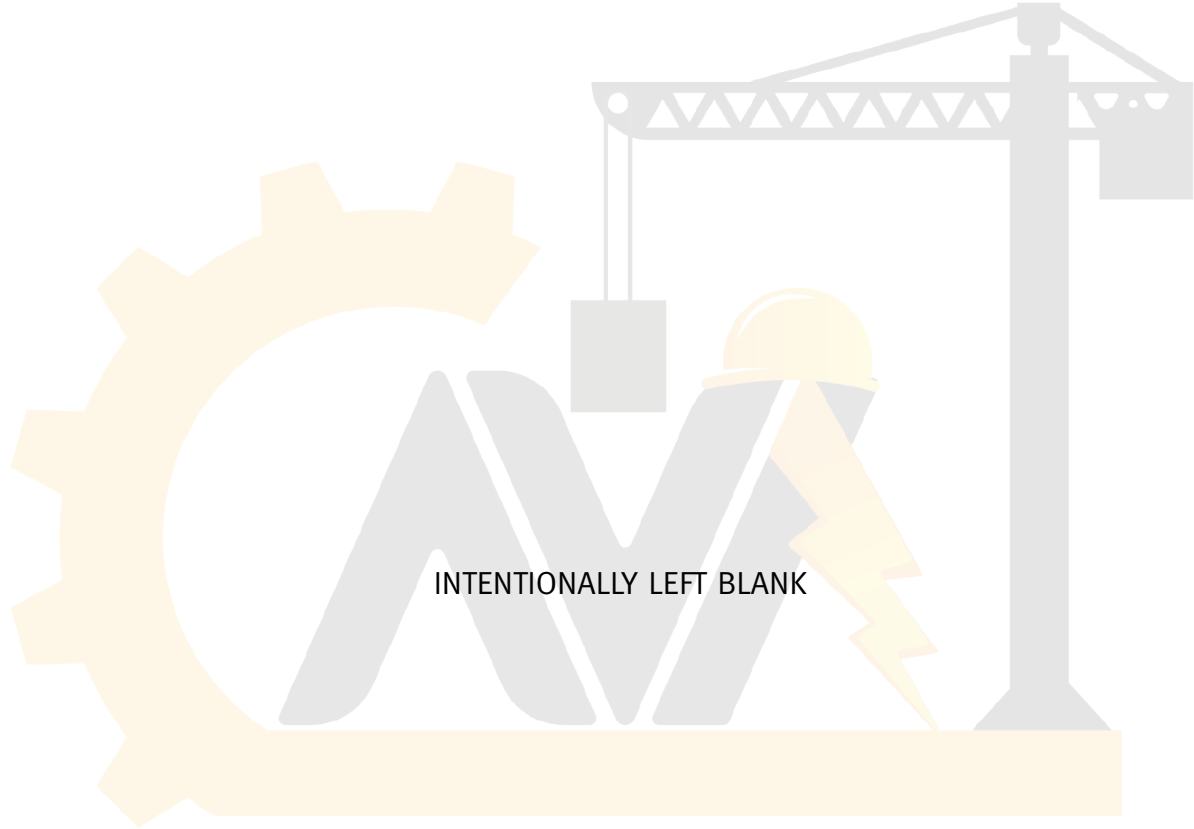

آریا ایمن آوات



30.17-2015

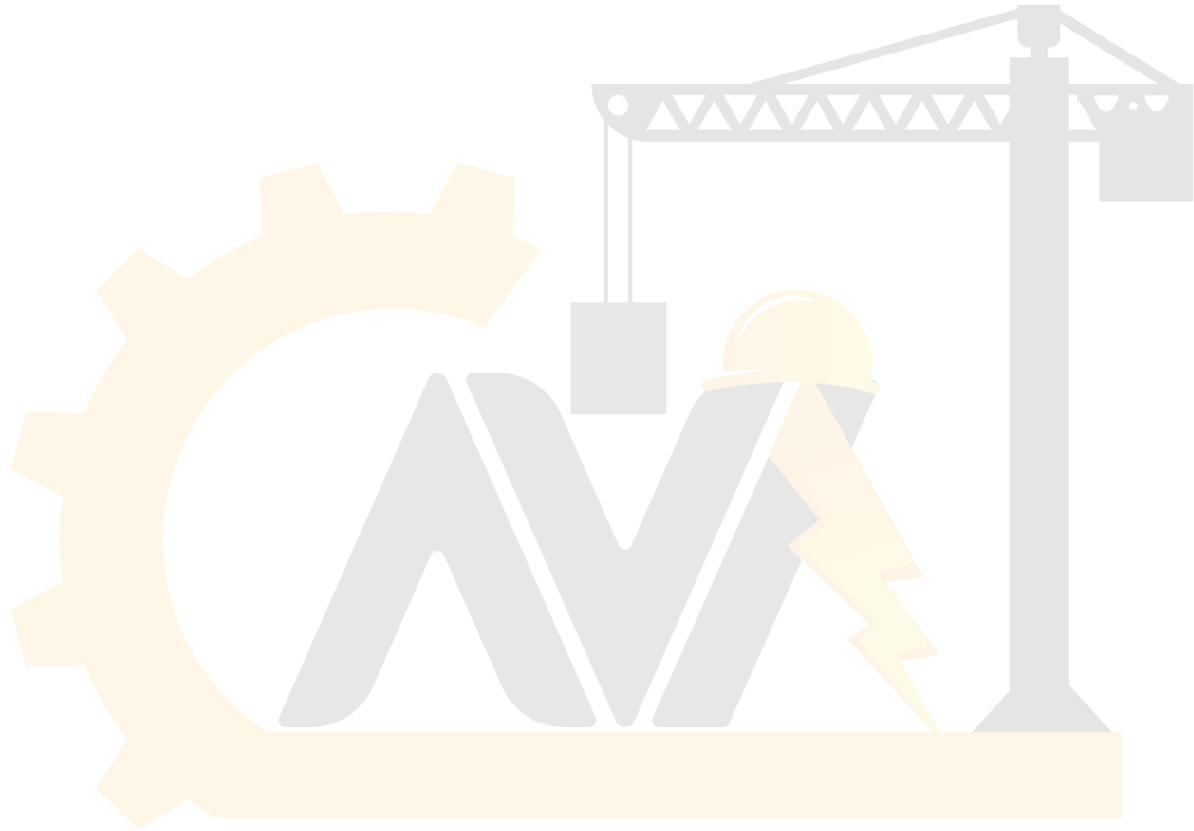

آریا ایمن آوات

ISBN 978-0-7918-7048-8



9 780791 870488



J06015