



**ASME B30.18-2016**  
(Revision of ASME B30.18-2011)

# Stacker Cranes

(Top or Under Running Bridge,  
Multiple Girder With Top or  
Under Running Trolley Hoist)

---

**Safety Standard for Cableways, Cranes,  
Derricks, Hoists, Hooks, Jacks, and  
Slings**

AN AMERICAN NATIONAL STANDARD



The American Society of  
Mechanical Engineers



**ASME B30.18-2016**  
(Revision of ASME B30.18-2011)

# Stacker Cranes

**(Top or Under Running Bridge,  
Multiple Girder With Top or  
Under Running Trolley Hoist)**

---

**Safety Standard for Cableways, Cranes,  
Derricks, Hoists, Hooks, Jacks, and  
Slings**

**AN AMERICAN NATIONAL STANDARD**



**The American Society of  
Mechanical Engineers**

Two Park Avenue • New York, NY • 10016 USA



Date of Issuance: August 26, 2016

The next edition of this Standard is scheduled for publication in 2021. This Standard will become effective 1 year after the Date of Issuance.

ASME issues written replies to inquiries concerning interpretations of technical aspects of this Standard. Interpretations are published on the Committee Web page and under [go.asme.org/InterpsDatabase](http://go.asme.org/InterpsDatabase).

Errata to codes and standards may be posted on the ASME Web site under the Committee Pages to provide corrections to incorrectly published items, or to correct typographical or grammatical errors in codes and standards. Such errata shall be used on the date posted.

The Committee Pages can be found at <http://cstools.asme.org/>. There is an option available to automatically receive an e-mail notification when errata are posted to a particular code or standard. This option can be found on the appropriate Committee Page after selecting “Errata” in the “Publication Information” section.

ASME is the registered trademark of The American Society of Mechanical Engineers.

This code or standard was developed under procedures accredited as meeting the criteria for American National Standards. The Standards Committee that approved the code or standard was balanced to assure that individuals from competent and concerned interests have had an opportunity to participate. The proposed code or standard was made available for public review and comment that provides an opportunity for additional public input from industry, academia, regulatory agencies, and the public-at-large.

ASME does not “approve,” “rate,” or “endorse” any item, construction, proprietary device, or activity.

ASME does not take any position with respect to the validity of any patent rights asserted in connection with any items mentioned in this document, and does not undertake to insure anyone utilizing a standard against liability for infringement of any applicable letters patent, nor assume any such liability. Users of a code or standard are expressly advised that determination of the validity of any such patent rights, and the risk of infringement of such rights, is entirely their own responsibility.

Participation by federal agency representative(s) or person(s) affiliated with industry is not to be interpreted as government or industry endorsement of this code or standard.

ASME accepts responsibility for only those interpretations of this document issued in accordance with the established ASME procedures and policies, which precludes the issuance of interpretations by individuals.

No part of this document may be reproduced in any form,  
in an electronic retrieval system or otherwise,  
without the prior written permission of the publisher.

The American Society of Mechanical Engineers  
Two Park Avenue, New York, NY 10016-5990

Copyright © 2016 by  
THE AMERICAN SOCIETY OF MECHANICAL ENGINEERS  
All rights reserved  
Printed in U.S.A.





## FOREWORD

This American National Standard, Safety Standard for Cableways, Cranes, Derricks, Hoists, Hooks, Jacks, and Slings, has been developed under the procedures accredited by the American National Standards Institute (ANSI). This Standard had its beginning in December 1916 when an eight-page "Code of Safety Standards for Cranes," prepared by an ASME Committee on the Protection of Industrial Workers, was presented at the annual meeting of the ASME.

Meetings and discussions regarding safety on cranes, derricks, and hoists were held from 1920 to 1925, involving the ASME Safety Code Correlating Committee, the Association of Iron and Steel Electrical Engineers, the American Museum of Safety, the American Engineering Standards Committee (AESC) [later changed to American Standards Association (ASA), then to the United States of America Standards Institute (USASI), and finally to ANSI], Department of Labor – State of New Jersey, Department of Labor and Industry – State of Pennsylvania, and the Locomotive Crane Manufacturers Association. On June 11, 1925, AESC approved the ASME Safety Code Correlating Committee's recommendation and authorized the project with the U.S. Department of the Navy, Bureau of Yards and Docks, and ASME as sponsors.

In March 1926, invitations were issued to 50 organizations to appoint representatives to a Sectional Committee. The call for organization of this Sectional Committee was sent out October 2, 1926, and the committee organized November 4, 1926, with 57 members representing 29 national organizations. Commencing June 1, 1927, and using the eight-page code published by ASME in 1916 as a basis, the Sectional Committee developed the "Safety Code for Cranes, Derricks, and Hoists." The early drafts of this safety code included requirements for jacks but, due to inputs and comments on those drafts, the Sectional Committee decided in 1938 to make the requirements for jacks a separate code.

In January 1943, ASA B30.2-1943 was published addressing a multitude of equipment types and in August 1943, ASA B30.1-1943 was published addressing just jacks. Both documents were reaffirmed in 1952 and widely accepted as safety standards.

Due to changes in design, advancement in techniques, and general interest of labor and industry in safety, the Sectional Committee, under the joint sponsorship of ASME and the Bureau of Yards and Docks (now the Naval Facilities Engineering Command) was reorganized on January 31, 1962, with 39 members representing 27 national organizations. The new committee changed the format of ASA B30.2-1943 so that the multitude of equipment types it addressed could be published in separate volumes that could completely cover the construction, installation, inspection, testing, maintenance, and operation of each type of equipment that was included in the scope of ASA B30.2. This format change resulted in the initial publication of B30.3, B30.5, B30.6, B30.11, and B30.16 being designated as revisions of B30.2 with the remainder of the B30 volumes being published as totally new volumes. ASA changed its name to USASI in 1966 and to ANSI in 1969, which resulted in B30 volumes from 1943 to 1968 being designated as either "ASA B30," "USAS B30," or "ANSI B30" depending on their date of publication.

In 1982, the Committee was reorganized as an Accredited Organization Committee, operating under procedures developed by ASME and accredited by ANSI. This Standard presents a coordinated set of rules that may serve as a guide to government and other regulatory bodies and municipal authorities responsible for the guarding and inspection of the equipment falling within its scope. The suggestions leading to accident prevention are given both as mandatory and advisory provisions; compliance with both types may be required by employers of their employees.

In case of practical difficulties, new developments, or unnecessary hardship, the administrative or regulatory authority may grant variances from the literal requirements or permit the use of other devices or methods, but only when it is clearly evident that an equivalent degree of protection is thereby secured. To secure uniform application and interpretation of this Standard, administrative or regulatory authorities are urged to consult the B30 Committee, in accordance with the format described in Section IX of the introduction, before rendering decisions on disputed points.



Safety codes and standards are intended to enhance public safety. Revisions result from committee consideration of factors such as technological advances, new data, and changing environmental and industry needs. Revisions do not imply that previous editions were inadequate.

The first edition of B30.18 was issued in 1987, and new editions were published in 1993, 1998, 2004, and 2011. This 2016 Edition includes revisions to add personnel competence requirements, revised definitions and references, updated inspection and testing requirements, and revised operator responsibilities.

This Edition of the B30.18 volume was approved by the B30 Committee and by ASME, and was approved by ANSI and designated as an American National Standard on July 8, 2016.

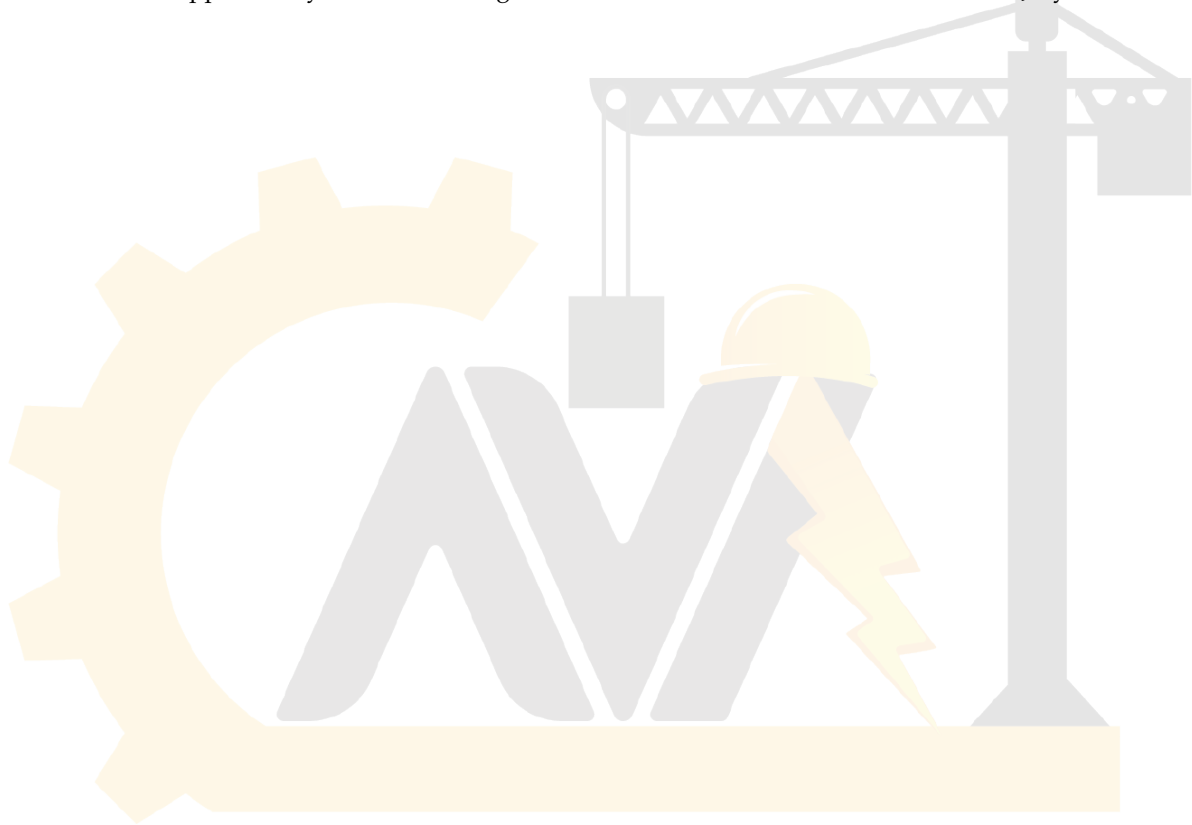

# آریا ایمن آوات



# ASME B30 COMMITTEE

## Safety Standard for Cableways, Cranes, Derricks, Hoists, Hooks, Jacks, and Slings

(The following is the roster of the Committee at the time of approval of this Standard.)

### STANDARDS COMMITTEE OFFICERS

**B. D. Closson**, *Chair*  
**T. L. Blanton**, *Vice Chair*  
**K. M. Hyam**, *Secretary*

### STANDARDS COMMITTEE PERSONNEL

**N. E. Andrew**, LTS Cranes Mechanical  
**M. Eggenberger**, *Alternate*, Berry Contracting, Inc.  
**G. Austin**, Terex Corp.  
**T. L. Blanton**, NACB Group, Inc.  
**P. A. Boeckman**, The Crosby Group, Inc.  
**E. E. Lutter**, *Alternate*, The Crosby Group, Inc.  
**P. W. Boyd**, The Boeing Co.  
**B. D. Closson**, Craft Forensic Services  
**J. A. Danielson**, The Boeing Co.  
**B. M. Casey**, *Alternate*, General Dynamics Electric Boat  
**D. R. Decker**, Becket, LLC  
**L. D. DeMark**, Equipment Training Solutions, LLC  
**D. F. Jordan**, *Alternate*, BP America  
**D. W. Eckstine**, Eckstine & Associates  
**G. J. Brent**, *Alternate*, NCCCO  
**R. J. Edwards**, NBIS Claims and Risk Management, Inc.  
**A. J. Egging**, National Oilwell Varco  
**R. Stanoch**, *Alternate*, National Oilwell Varco  
**E. D. Fidler**, The Manitowoc Co.  
**G. D. Miller**, *Alternate*, The Manitowoc Co.  
**J. A. Gilbert**, Associated Wire Rope Fabricators  
**J. L. Gordon**, Acco Chain & Lifting Products  
**N. C. Hargreaves**, Hargreaves Consulting, LLC  
**G. B. Hetherston**, Consultant  
**R. J. Bolen**, *Alternate*, E. I. DuPont  
**K. M. Hyam**, The American Society of Mechanical Engineers  
**M. M. Jaxheimer**, Navy Crane Center  
**S. R. Gridley**, *Alternate*, Navy Crane Center  
**P. R. Juhren**, Morrow Equipment Co., LLC  
**M. J. Quinn**, *Alternate*, Morrow Equipment Co., LLC  
**R. M. Kohner**, Landmark Engineering Services, Ltd.  
**D. Duerr**, *Alternate*, 2DM Associates, Inc.  
**A. J. Lusi, Jr.**, Lumark Consulting, LLP  
**K. J. Shinn**, *Alternate*, K. J. Shinn, Inc.  
**E. K. Marburg**, Columbus McKinnon Corp.  
**J. R. Burkey**, *Alternate*, Columbus McKinnon Corp.  
**L. D. Means**, Means Engineering & Consulting  
**D. A. Henninger**, *Alternate*, Bridon American  
**M. W. Mills**, Liberty Mutual Insurance  
**D. M. Gordon**, *Alternate*, Liberty Mutual Insurance  
**D. L. Morgan**, Critical Lift Consultants, LLC  
**T. C. Mackey**, *Alternate*, WRPS Hanford  
**W. E. Osborn**, Ingersoll Rand  
**S. D. Wood**, *Alternate*, Link-Belt Construction Equipment Co.  
**R. M. Parnell**, Industrial Training International  
**W. C. Dickinson, Jr.**, *Alternate*, Industrial Training International  
**J. T. Perkins**, Solarex  
**J. R. Schober**, *Alternate*, American Bridge Co.  
**B. A. Pickett**, Systems Engineering and Forensic Services  
**S. K. Rammelsberg**, Chicago Bridge & Iron Co.  
**J. E. Richardson**, Navy Crane Center  
**K. Kennedy**, *Alternate*, Navy Crane Center  
**D. W. Ritchie**, David Ritchie Consultant, LLC  
**L. K. Shapiro**, *Alternate*, Howard I. Shapiro & Associates  
**J. W. Rowland III**, Consultant  
**D. A. Moore**, *Alternate*, Unified Engineering  
**J. C. Ryan**, Boh Bros. Construction Co., LLC  
**A. R. Ruud**, *Alternate*, Atkinson Construction  
**D. W. Smith**, STI Group  
**W. J. Smith, Jr.**, NBIS Claims and Risk Management, Inc.  
**J. Schoppert**, *Alternate*, NBIS Claims and Risk Management, Inc.  
**R. S. Stemp**, Lampson International, LLC  
**E. P. Vliet**, *Alternate*, Turner Industries Group  
**R. G. Strain**, Advanced Crane Technologies, LLC  
**J. Sturm**, Sturm Corp.  
**P. D. Sweeney**, General Dynamics Electric Boat  
**J. D. Wiethorn**, Haag Engineering Co.  
**M. Gardiner**, *Alternate*, Haag Engineering Co.  
**R. C. Wild**, CJ Drilling, Inc.  
**J. Dudley**, *Alternate*, Archer Western Contractors  
**D. N. Wolff**, National Crane/Manitowoc Crane Group  
**J. A. Pilgrim**, *Alternate*, Manitowoc Crane Group



## HONORARY MEMBERS

**J. W. Downs, Jr.**, Downs Crane and Hoist Co.  
**J. L. Franks**, Consultant  
**C. W. Ireland**, National Oilwell Varco  
**J. M. Klibert**, Lift-All Co., Inc.  
**R. W. Parry**, Consultant

## B30.18 SUBCOMMITTEE PERSONNEL

**D. A. Moore**, *Chair* United Engineering  
**J. A. Danielson**, Boeing Co.  
**J. L. Gordon**, Acco Chain & Lifting Products

**J. M. Randall**, CB&I  
**R. G. Strain**, Advanced Crane Technologies, LLC

## B30 INTEREST REVIEW GROUP

**O. Akinboboye**, Ropetech Engineering Services  
**J. D. Cannon**, Consultant  
**M. J. Eggenberger**, Berry Contracting, Inc.  
**A. Gomes Rocha**, Belgo Bekaert Arames  
**H. A. Hashem**, Saudi Aramco  
**J. Hui**, School of Civil Engineering, Nanjing  
**C. Lan**, U.S. Department of the Interior — Bureau of Safety and Environmental Enforcement

**A. C. Mattoli**, Prowinch, LLC  
**J. P. Muhlauer**, All Ship and Cargo Surveys, Ltd.  
**M. W. Osborne**, E-Crane International USA  
**G. L. Owens**, Consultant  
**D. R. Remus**, Reed Manufacturing  
**W. G. Rumburg**, Crane Consultants, Inc.  
**C.-C. Tsauro**, Institute of Occupational Safety and Health

## B30 REGULATORY AUTHORITY COUNCIL

**C. Shelhamer**, *Chair*, New York City Department of Buildings  
**A. O. Omran**, *Alternate*, New York City Department of Buildings  
**K. M. Hyam**, *Secretary*, The American Society of Mechanical Engineers  
**L. G. Campion**, U.S. Department of Labor/OSHA  
**R. Feidt**, Stephenson Equipment, Inc.  
**C. Harris**, City of Chicago — Department of Buildings  
**R. D. Jackson**, U.S. Department of Labor

**J. L. Lankford**, State of Nevada (OSHA)  
**A. Lundeen**, State of Washington — Department of Labor and Industries  
**M. J. Nelmida**, State of California — OSH Standards Board  
**G. E. Pushies**, Michigan Occupational Safety and Health Administration  
**C. N. Stribling, Jr.**, Kentucky Labor Cabinet  
**T. Taylor**, State of Minnesota — Department of Labor and Industry

آریا ایمن آوات





# SAFETY STANDARD FOR CABLEWAYS, CRANES, DERRICKS, HOISTS, HOOKS, JACKS, AND SLINGS

(16)

## B30 STANDARD INTRODUCTION

### SECTION I: SCOPE

The ASME B30 Standard contains provisions that apply to the construction, installation, operation, inspection, testing, maintenance, and use of cranes and other lifting and material-movement related equipment. For the convenience of the reader, the Standard has been divided into separate volumes. Each volume has been written under the direction of the ASME B30 Standard Committee and has successfully completed a consensus approval process under the general auspices of the American National Standards Institute (ANSI).

As of the date of issuance of this Volume, the B30 Standard comprises the following volumes:

- B30.1 Jacks, Industrial Rollers, Air Casters, and Hydraulic Gantries
- B30.2 Overhead and Gantry Cranes (Top Running Bridge, Single or Multiple Girder, Top Running Trolley Hoist)
- B30.3 Tower Cranes
- B30.4 Portal and Pedestal Cranes
- B30.5 Mobile and Locomotive Cranes
- B30.6 Derricks
- B30.7 Winches
- B30.8 Floating Cranes and Floating Derricks
- B30.9 Slings
- B30.10 Hooks
- B30.11 Monorails and Underhung Cranes
- B30.12 Handling Loads Suspended From Rotorcraft
- B30.13 Storage/Retrieval (S/R) Machines and Associated Equipment
- B30.14 Side Boom Tractors
- B30.15 Mobile Hydraulic Cranes  
(withdrawn 1982 — requirements found in latest revision of B30.5)
- B30.16 Overhead Hoists (Underhung)
- B30.17 Overhead and Gantry Cranes (Top Running Bridge, Single Girder, Underhung Hoist)
- B30.18 Stacker Cranes (Top or Under Running Bridge, Multiple Girder With Top or Under Running Trolley Hoist)
- B30.19 Cableways
- B30.20 Below-the-Hook Lifting Devices
- B30.21 Lever Hoists
- B30.22 Articulating Boom Cranes

- B30.23 Personnel Lifting Systems
- B30.24 Container Cranes
- B30.25 Scrap and Material Handlers
- B30.26 Rigging Hardware
- B30.27 Material Placement Systems
- B30.28 Balance Lifting Units
- B30.29 Self-Erecting Tower Cranes
- B30.30 Ropes<sup>1</sup>

### SECTION II: SCOPE EXCLUSIONS

Any exclusion of, or limitations applicable to the equipment, requirements, recommendations or operations contained in this Standard are established in the affected volume's scope.

### SECTION III: PURPOSE

The B30 Standard is intended to

- (a) prevent or minimize injury to workers, and otherwise provide for the protection of life, limb, and property by prescribing safety requirements
- (b) provide direction to manufacturers, owners, employers, users, and others concerned with, or responsible for, its application
- (c) guide governments and other regulatory bodies in the development, promulgation, and enforcement of appropriate safety directives

### SECTION IV: USE BY REGULATORY AGENCIES

These volumes may be adopted in whole or in part for governmental or regulatory use. If adopted for governmental use, the references to other national codes and standards in the specific volumes may be changed to refer to the corresponding regulations of the governmental authorities.

### SECTION V: EFFECTIVE DATE

(a) *Effective Date.* The effective date of this Volume of the B30 Standard shall be 1 yr after its date of issuance.

<sup>1</sup> This volume is currently in the development process.



tion, installation, inspection, testing, maintenance and operation of equipment manufactured and facilities constructed after the effective date of this Volume shall conform to the mandatory requirements of this Volume.

(b) *Existing Installations.* Equipment manufactured and facilities constructed prior to the effective date of this Volume of the B30 Standard shall be subject to the inspection, testing, maintenance, and operation requirements of this Standard after the effective date.

It is not the intent of this Volume of the B30 Standard to require retrofitting of existing equipment. However, when an item is being modified, its performance requirements shall be reviewed relative to the requirements within the current volume. The need to meet the current requirements shall be evaluated by a qualified person selected by the owner (user). Recommended changes shall be made by the owner (user) within 1 yr.

## SECTION VI: REQUIREMENTS AND RECOMMENDATIONS

Requirements of this Standard are characterized by use of the word *shall*. Recommendations of this Standard are characterized by the word *should*.

## SECTION VII: USE OF MEASUREMENT UNITS

This Standard contains SI (metric) units as well as U.S. Customary units. The values stated in U.S. Customary units are to be regarded as the standard. The SI units are a direct (soft) conversion from the U.S. Customary units.

## SECTION VIII: REQUESTS FOR REVISION

The B30 Standard Committee will consider requests for revision of any of the volumes within the B30 Standard. Such requests should be directed to

Secretary, B30 Standard Committee  
ASME Codes and Standards  
Two Park Avenue  
New York, NY 10016-5990

Requests should be in the following format:

- Volume: Cite the designation and title of the volume.  
Edition: Cite the applicable edition of the volume.  
Subject: Cite the applicable paragraph number(s) and the relevant heading(s).  
Request: Indicate the suggested revision.  
Rationale: State the rationale for the suggested revision.

Upon receipt by the Secretary, the request will be forwarded to the relevant B30 Subcommittee for consideration and action. Correspondence will be provided to

the requester defining the actions undertaken by the B30 Standard Committee.

## SECTION IX: REQUESTS FOR INTERPRETATION

The B30 Standard Committee will render an interpretation of the provisions of the B30 Standard. An Interpretation Submittal Form is available on ASME's website at <http://cstools.asme.org/Interpretation/InterpretationForm.cfm>.

Phrase the question as a request for an interpretation of a specific provision suitable for general understanding and use, not as a request for approval of a proprietary design or situation. Plans or drawings that explain the question may be submitted to clarify the question. However, they should not contain any proprietary names or information. Read carefully the note addressing the types of requests that the B30 Standard Committee can and cannot consider.

Upon submittal, the request will be forwarded to the relevant B30 Subcommittee for a draft response, which will then be subject to approval by the B30 Standard Committee prior to its formal issuance. The B30 Standard Committee may rewrite the question for the sake of clarity.

Interpretations to the B30 Standard will be available online at <https://cstools.asme.org/Interpretation/SearchInterpretation.cfm>.

## SECTION X: ADDITIONAL GUIDANCE

The equipment covered by the B30 Standard is subject to hazards that cannot be abated by mechanical means, but only by the exercise of intelligence, care, and common sense. It is therefore essential to have personnel involved in the use and operation of equipment who are competent, careful, physically and mentally qualified, and trained in the proper operation of the equipment and the handling of loads. Serious hazards include, but are not limited to, improper or inadequate maintenance, overloading, dropping or slipping of the load, obstructing the free passage of the load, and using equipment for a purpose for which it was not intended or designed.

The B30 Standard Committee fully realizes the importance of proper design factors, minimum or maximum dimensions, and other limiting criteria of wire rope or chain and their fastenings, sheaves, sprockets, drums, and similar equipment covered by the standard, all of which are closely connected with safety. Sizes, strengths, and similar criteria are dependent on many different factors, often varying with the installation and uses. These factors depend on

- (a) the condition of the equipment or material
- (b) the loads
- (c) the acceleration or speed of the ropes, chains, sheaves, sprockets, or drums



e of attachments

number, size, and arrangement of sheaves or

parts

(f) environmental conditions causing corrosion or wear

(g) many variables that must be considered in each individual case

The requirements and recommendations provided in the volumes must be interpreted accordingly, and judgment used in determining their application.

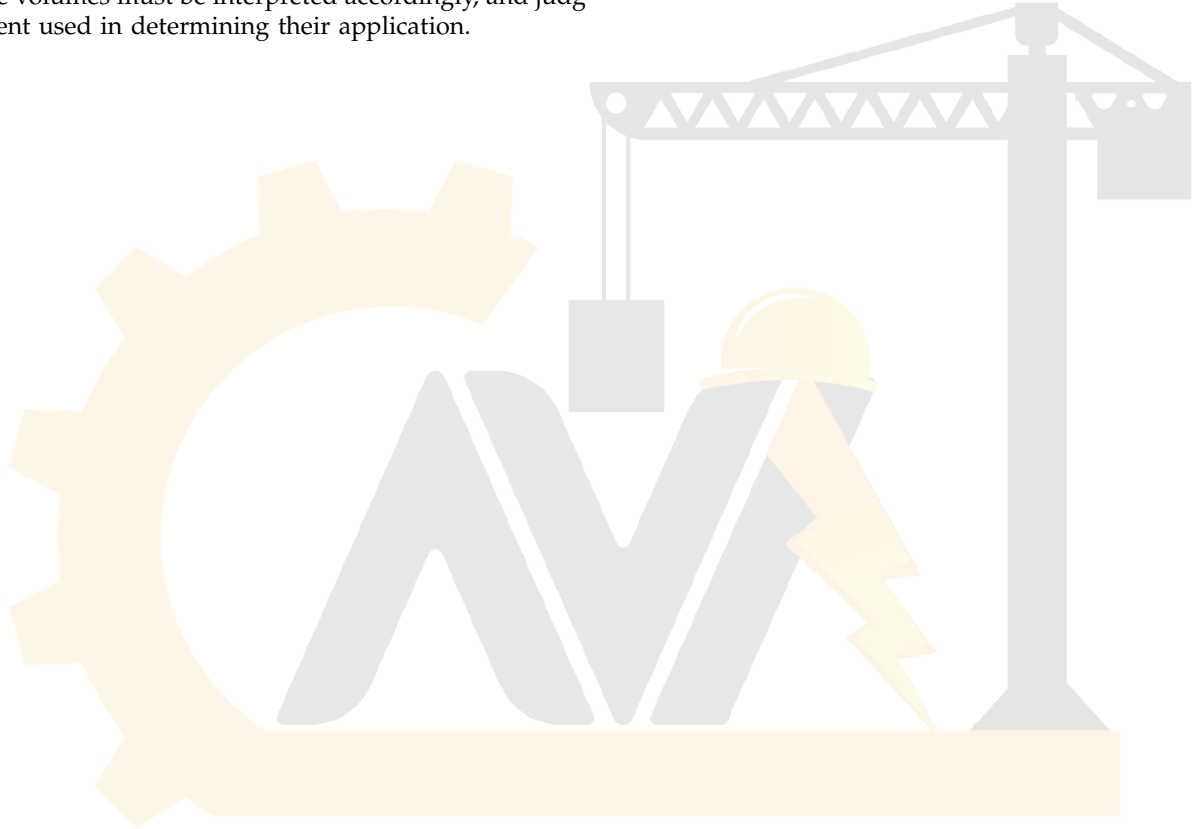

# آریا ایمن آوات

## ASME B30.18-2016 SUMMARY OF CHANGES

Following approval by the ASME B30 Committee and ASME, and after public review, ASME B30.18-2016 was approved by the American National Standards Institute on July 8, 2016.

ASME B30.18-2016 also includes editorial changes, revisions, and corrections identified by a margin note, (16).

<i>Page</i>	<i>Location</i>	<i>Change</i>
viii–x	Introduction	Revised
1–7	18-0.2.1	Revised in its entirety
	18-0.2.2	Revised in its entirety
	Section 18-0.3	Added with former Section 18-0.3 redesignated to 18-0.4
	Section 18-0.4	Updated
8	18-1.1.3	In subparas. (a) and (b), reference revised
	18-1.1.4	Added
9	18-1.3.1	In subpara. (c), reference revised
	18-1.3.2	Subparagraph (a)(1) revised
	18-1.4.3	Revised
10	18-1.5.2	Reference revised
	18-1.6.4	In subpara. (c), reference revised
11	18-1.7.6	In subpara. (b), last sentence deleted
19–22	18-2.1.1	Added with former para. 18-2.1.1 and subsequent paragraphs redesignated
	18-2.1.2	Subparagraphs (b)(1) and (b)(2) revised
	18-2.1.4	Revised
	18-2.1.6	Revised
	18-2.2.1	Subparagraph (a) revised
	18-2.3.1	Subparagraph (a) revised
	18-2.3.2	Subparagraphs (a)(1) and (a)(5) revised
	18-2.4.1	Added with former para. 18-2.4.1 and subsequent paragraphs redesignated
	18-2.4.2	Subparagraphs (a)(1) and (b)(2) revised

*Location*

*Change*

18-2.4.3

- (1) Subparagraph (b)(1) revised
- (2) Subparagraph (b)(4) deleted and subsequent subparagraphs redesignated
- (3) Subparagraph (b)(6) revised and table underneath deleted

18-3.1.1

- (1) Title revised
- (2) Subparagraph (a) revised

18-3.1.2

- (1) Title revised
- (2) Subparagraph (a) revised
- (3) New subpara. (b) added and subsequent subparagraphs redesignated

18-3.1.3

Revised, previous text incorporated into para. 18-3.1.1

18-3.2

- (1) Formerly 18-3.1.7, redesignated as 18-3.2 with subsequent Sections redesignated
- (2) Subparagraphs (f) and (i) revised

18-3.3.3

Subparagraph (a) revised

18-3.4.4

In subpara. (b), reference revised



# STACKER CRANES (TOP OR UNDER RUNNING BRIDGE, MULTIPLE GIRDER WITH TOP OR UNDER RUNNING TROLLEY HOIST)

## Chapter 18-0 Scope, Definitions, Personnel Competence, and References

### SECTION 18-0.1: SCOPE OF B30.18

Volume B30.18 includes provisions that apply to the construction, installation, operation, inspection, and maintenance of hand-powered and power-driven overhead and gantry cranes that have a top or under running multiple girder bridge with a vertically guided carriage, with or without a top or under running trolley. The requirements included in this Volume also apply to stacker cranes having the same fundamental characteristics, such as cantilever gantry and semi-gantry stacker cranes.

### SECTION 18-0.2: DEFINITIONS

#### (16) 18-0.2.1 Types of Equipment

*cab-operated stacker crane:* a crane controlled by an operator in a cab that is attached to the bridge mast, trolley, stacker mast, or load carriage (see Fig. 18-0.2.1-1).

*cantilever gantry stacker crane:* a gantry or semi-gantry crane in which the bridge girders extend transversely beyond the crane runway on one or both sides.

*crane:* a machine for lifting and lowering a load and moving it horizontally, with the hoisting mechanism being an integral part of the machine.

*floor-operated stacker crane:* a crane that is controlled by an operator on the floor or an independent platform using a means suspended from the crane (see Fig. 18-0.2.1-2).

*gantry stacker crane:* a crane similar to an overhead crane except that the bridge for carrying the trolley(s) is rigidly supported on two or more legs running on fixed rails or other runway.

*outdoor crane:* an overhead or gantry crane that operates outdoors and for which provisions are not available for storage in an area that provides protection to the crane from weather conditions. An indoor crane that may

operate outdoors on a periodic basis is not classified as an outdoor crane.

*power-operated stacker crane:* a crane whose mechanism is driven by electric, air, or hydraulic means.

*pulpit-operated crane:* a crane operated from a fixed operator station not attached to the crane.

*remote-operated crane:* a crane whose movements are controlled by an operator through the use of controllers contained in a portable operating station not attached to the crane.

*semi-gantry stacker crane:* a gantry crane with one end of the bridge rigidly supported on one or more legs that run on a fixed rail or runway, the other end of the bridge supported by a truck running on an elevated rail or runway.

*stacker crane:* a crane used for stacking and retrieving palletized or containerized materials, with a multiple girder movable bridge carrying a hoisting mechanism, mast, and carriage (see Fig. 18-0.2.1-3).

#### 18-0.2.2 General

*abnormal operating conditions:* environmental conditions that are unfavorable, harmful, or detrimental to the operation of the equipment, such as excessively high or low temperatures, exposure to adverse weather, corrosive fumes, dust- or moisture-laden atmospheres, and hazardous locations.

*aisle:* space between storage compartment rows in which the equipment may operate.

*ampacity:* current-carrying capacity of electric conductors, in amperes.

*automatic or automatically:* pertains to equipment functions that do not require the attention of the operator during their functional operation.

*brake:* a device, other than a motor, used for retarding or stopping motion by means of friction or power.

(16)

Fig. 18-0.2.1-1 Cab-Operated Stacker Crane

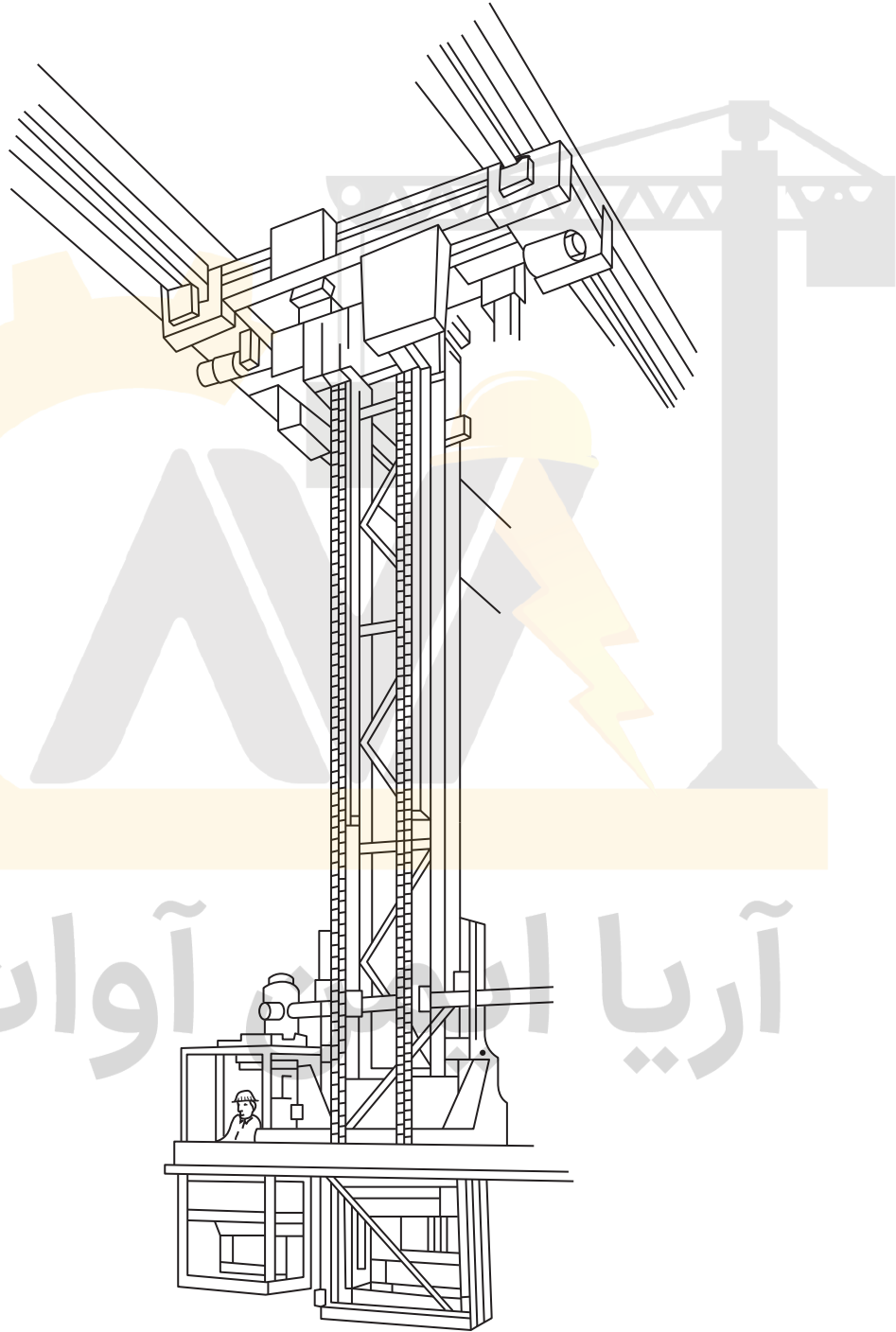
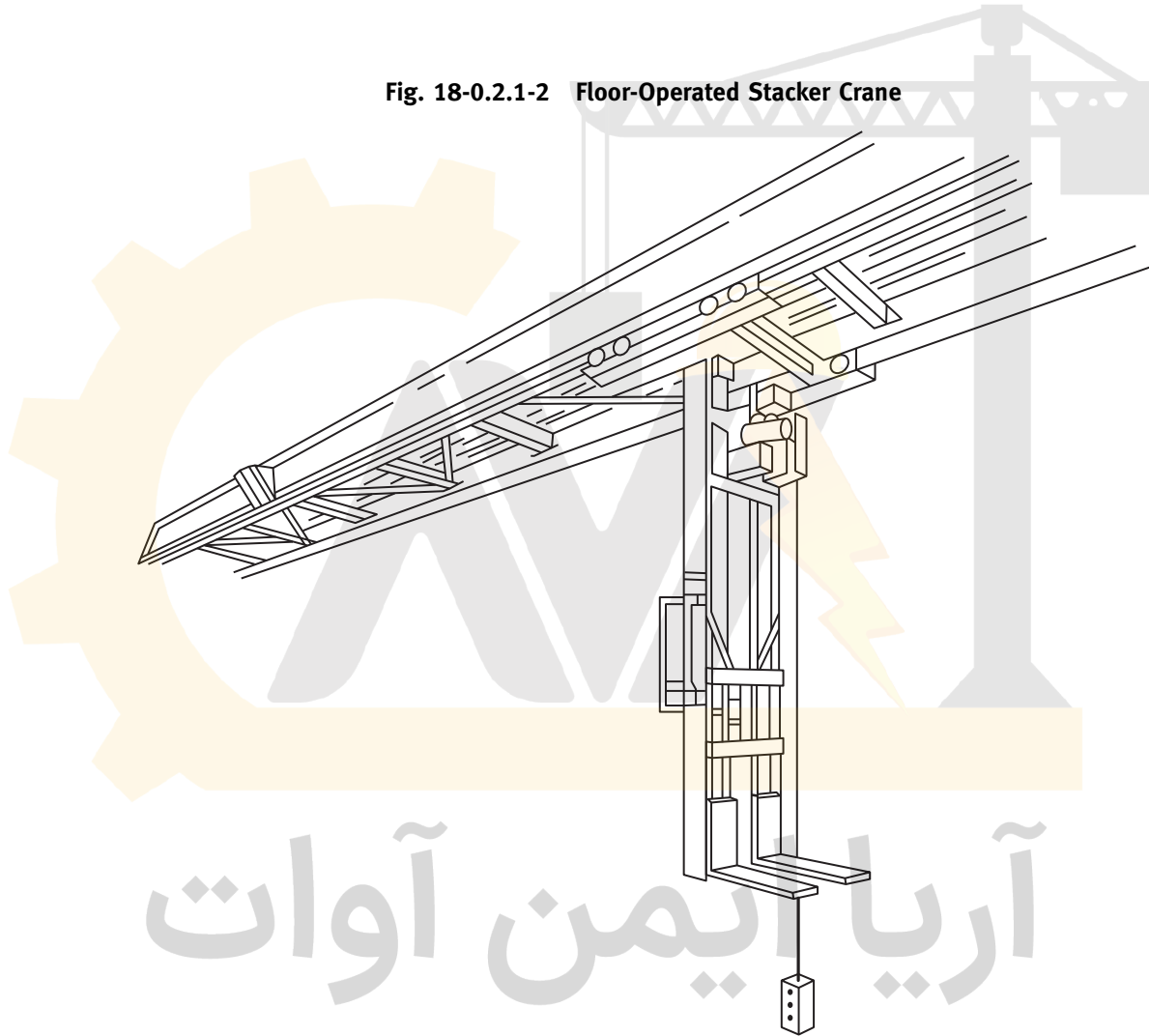



Fig. 18-0.2.1-2 Floor-Operated Stacker Crane



آریا امین آوات



Fig. 18-0.2.1-3 Underhung Stacker Crane Movement

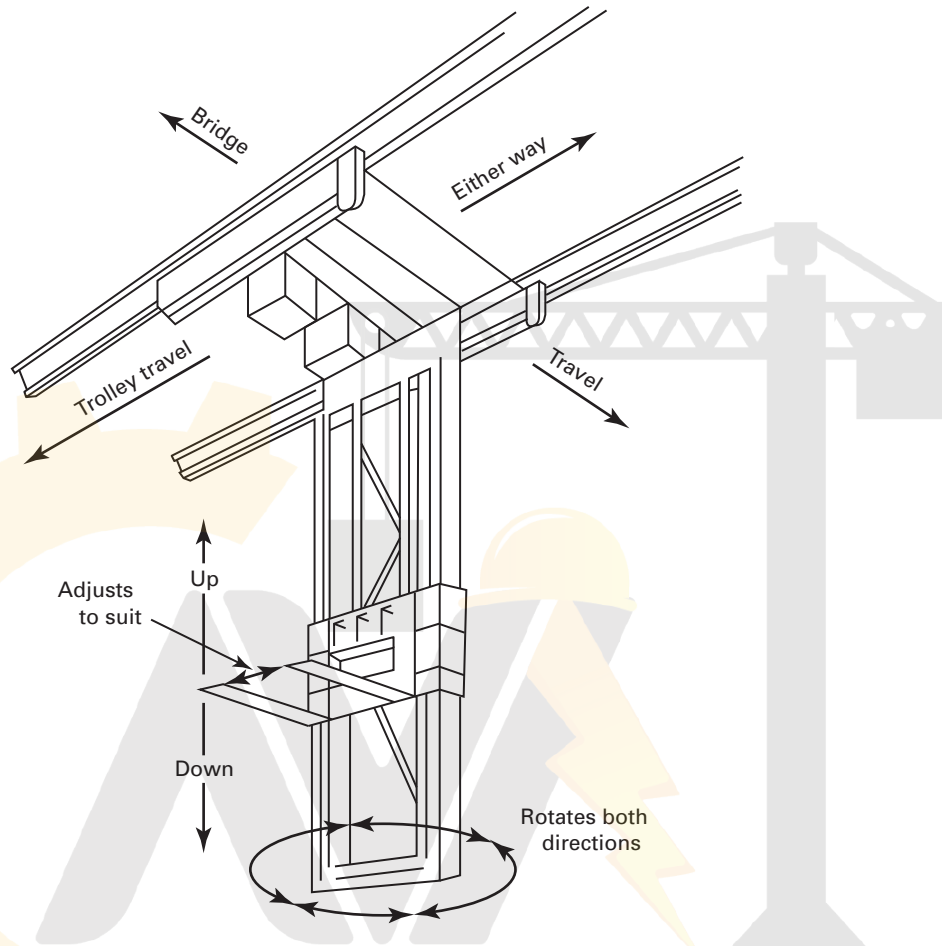

*bridge*: that part of a crane consisting of one or more girders, trucks, end ties, footwalks, and drive mechanism that carries the trolley or trolleys.

*bridge conductors*: the electrical conductors located along the bridge structure that transmit control signals and power to the trolley(s).

*bridge travel*: the movement in a direction parallel to the crane runway.

*bumper (buffer)*: a device for reducing impact when a moving crane or trolley reaches the end of its permitted travel, or when two moving cranes or trolleys come into contact. This device may be attached to the crane, trolley, or runway stop.

*cab*: the operator's compartment on the equipment.

*carriage*: the vertically moving structure of a stacker crane that supports the load.

*clearance*: distance from any part of the equipment to the nearest obstruction.

*control braking*: a method of controlling speed by removing energy from the moving body or by imparting energy in the opposite direction.

*control circuit voltage*: electrical voltage used in the control components and circuits.

*control panel*: an assembly of components (magnetic, static, hydraulic, pneumatic, etc.) that governs the flow of power to or from a motor or other equipment in response to signals from a master switch, push-button station, remote control, automatic program control, or other similar device.

*controller*: a device, or group of devices, that serves to govern, in a predetermined manner, the power delivered to the apparatus to which it is connected.

*countertorque braking (plugging)*: a method of control by which the power to the motor is reversed to develop torque in the direction opposite of the rotation of the motor.

*current collectors*: contacting devices for collecting current from runway or bridge conductors.

*drift point*: a point on a travel motion master switch or on a manual controller that maintains the brake released while the motor is not energized. This allows for coasting.



cylindrical member around which the rope is for lifting or lowering the load.

*dynamic braking*: a method of controlling speed by using the motor as a generator, with the energy being dissipated in resistors.

*eddy current braking*: a method of controlling or reducing speed by means of an electrical induction load brake.

*emergency brake*: a brake for travel motion that is released during normal operation and arranged to apply a retarding force when initiated by the operator during an emergency or to automatically apply a retarding force upon loss of power.

*emergency braking*: a method of decelerating a drive when power is not available. The braking effort may be established as a result of action by the operator or automatically when power to the drive is interrupted.

*end tie*: a structural member that connects the ends of the bridge girders to maintain squareness of the bridge.

*equalizer*: a device that compensates for unequal length or stretch of a rope.

*exposed*: applies to hazardous objects not guarded or isolated, and capable of being contacted inadvertently.

*footwalk*: a walkway with handrail on or attached to the bridge or trolley for access purposes.

*forks*: a load-bearing means mounted on the carriage.

*free fall stop*: a mechanism used to prevent or stop downward vertical travel of the carriage or cab in the event of loss of support.

*heavy service*: service that involves operating at 85% to 100% of rated load or in excess of 10 lift cycles/hr as a regular specified procedure.

*hoist*: a machinery unit that is used for lifting and lowering.

*hoist chain*: the chain in a hoist that supports the carriage and is calibrated to mate with sprockets, idlers, and pocket wheels.

*hoisting mechanism*: the means provided for lifting and lowering portions of the stacker and the rated load.

*holding brake*: a friction brake for a hoist that is automatically applied and prevents motion when power to the brake is off.

*home position*: the position that is both an originating point and terminating point of the stacker crane cycle.

*hydraulic braking*: a method of controlling or reducing speed by means of displacement of a liquid.

*limit switch*: a device that is operated by some part or motion of a power-driven machine or equipment to alter a circuit associated with the machine or equipment.

*load center*: a point on the forks, measured from the heel of the forks, that establishes the limiting distance on the

forks for positioning the center of gravity of the load to be lifted.

*main switch*: a switch controlling the main power supply to the equipment.

*manual controller*: a controller having all of its basic functions performed by devices that are operated by hand.

*mast*: a vertical structure, attached to the trolley, for guiding the carriage.

*master switch*: a device that dominates the operation of contactors and auxiliary devices of an enclosed circuit.

*mechanical braking*: a method of controlling or reducing speed by friction.

*noncoasting mechanical drive*: a drive that automatically results in decelerating a trolley or bridge when power is not available.

*normal operating conditions (of cab-operated cranes)*: conditions during which the equipment is performing functions within the scope of the original design. Under these conditions, the operator is at the operating control devices, and there is no other person on the equipment.

*normal operating conditions (of floor-operated cranes)*: conditions during which the equipment is performing functions within the scope of the original design. Under these conditions, the operator is at the operating control devices that are attached to the equipment but operated with the operator off the equipment and there is no person on the equipment.

*normal operating conditions (of remote-operated cranes)*: conditions during which the equipment is performing functions within the scope of the original design. Under these conditions, the operator is at the operating control devices that are not attached to any part of the equipment and with no other person on the equipment.

*normal service*: service that averages operating at less than 85% of rated load and not more than 10 lift cycles per hour for isolated instances.

*parking brake*: a brake for bridges and trolleys that may be automatically or manually applied in an attempt to prevent horizontal motion by restraining wheel rotation.

*qualified person*: a person, who by possession of a recognized degree in an applicable field, certificate of professional standing, or who by extensive knowledge, training, and experience, has successfully demonstrated the ability to solve or resolve problems relating to the subject matter and work.

*rail sweep*: a device attached to the crane and located in front of the crane's leading wheels to remove obstructions.

*rated load (capacity)*: the maximum load designated by the manufacturer for which equipment is designed and built.



*rated*: the speed at which the stacker crane is designed to operate under rated load.

*regenerative braking*: a method of controlling speed in which the electrical energy generated by the motor is fed back into the power system.

*rope*: refers to wire-rope unless otherwise specified.

*running sheave*: a sheave that rotates as a load carriage is lifted or lowered.

*runway*: an assembly of rails, beams, girders, brackets, and framework on which the crane travels.

*runway conductor (main)*: the electrical conductors located along the equipment runway to provide power or control to the equipment.

*service brake*: a brake for travel motion used by the operator during normal operation to apply a retarding force.

*service braking*: a method of decelerating motion during normal operation.

*severe service*: service that involves normal or heavy service with abnormal operating conditions.

*shall*: a word indicating a requirement.

*should*: a word indicating a recommendation.

*slave pallet* or *slave container*: a handling base or container that is normally captive to a system on which a unit load is supported.

*span*: the horizontal distance, center-to-center, between runway rails.

*spring return controller*: a controller that, when released, will return automatically to a neutral (off) position.

*stop*: a device to limit travel. This device normally is attached to a fixed structure and normally does not have energy absorbing ability.

*trolley*: the unit that travels on or is suspended from the bridge girders and supports the mast and carriage.

*trolley travel*: the trolley movement in directions at right angles to the crane runway.

*truck*: the unit, consisting of a frame, wheels, bearings, and axles, that supports the bridge girders, the end ties of an overhead stacker crane, or the sill of a gantry stacker crane.

*unattended*: a condition in which the operator is not at the operating control devices. On floor-controlled equipment, if the control devices are within an unobstructed distance of 26 ft (8 m), and within sight of the operator, the equipment is considered attended.

and capable to perform functions as determined by the employer or the employer's representative.

#### SECTION 18-0.4: REFERENCES TO OTHER CODES AND STANDARDS (16)

The following is a list of publications referenced in the volume.

AISC Steel Construction Manual, 14th Edition, 2011

Publisher: American Institute of Steel Construction (AISC), 1 East Wacker Drive, Suite 700, Chicago, IL 60616-1802 ([www.aisc.org](http://www.aisc.org))

ANSI/ASSE A1264.1-2007, Safety Requirements for Workplace Floor and Wall Openings, Stairs and Railings Systems

ANSI/ASSE Z244.1-2003 (R2014), Control of Hazardous Energy — Lockout/Tagout & Alternative Methods

Publisher: The American Society of Safety Engineers (ASSE), 1800 East Oakton Street, Des Plaines, IL 60018 ([www.asse.org](http://www.asse.org))

ANSI MH27.1-2009, Specifications for Patented Track Underhung Cranes and Monorail Systems

Publisher: Monorail Manufacturers Association, Inc. (MMA), 8720 Red Oak Boulevard, Charlotte, NC 28217 ([www.mhi.org/mma](http://www.mhi.org/mma))

ANSI/SAE Z26.1-1996, American National Standard for Safety Glazing Materials for Glazing Motor Vehicles and Motor Vehicle Equipment Operating on Land Highways

Publisher: SAE International, 400 Commonwealth Drive, Warrendale, PA 15096-0001 ([www.sae.org](http://www.sae.org))

ANSI-ASC A14.3-2008, Ladders — Fixed — Safety Requirements

Publisher: American Ladder Institute (ALI), 330 N. Wabash, Chicago IL 60611 ([www.americanladderinstitute.org](http://www.americanladderinstitute.org))

ANSI/AWS D1.1-2010, Structural Welding Code: Steel  
ANSI/AWS D14.1-2005, Specifications for Welding Industrial and Mill Cranes and Other Material Handling Equipment

Publisher: American Welding Society (AWS), 8669 NW 36 Street, No. 130, Miami, FL 33166-6672 ([www.aws.org](http://www.aws.org))

ANSI/NEMA Z535.4-2011, Product Safety Signs and Labels

Publisher: National Electrical Manufacturers Association (NEMA), 1300 North 17th Street, Suite 900, Arlington, VA 22029 ([www.nema.org](http://www.nema.org))

#### (16) SECTION 18-0.3: PERSONNEL COMPETENCE

Persons performing the functions identified in this Volume shall, through education, training, experience, skill, and physical fitness, as necessary, be competent



FPA 70-2014, National Electrical Code  
Publisher: National Fire Protection Association (NFPA),  
Batterymarch Park, Quincy, MA 02169-7471  
(www.nfpa.org)

ASCE/SEI 7, Minimum Design Loads for Buildings and  
Other Structures  
Publisher: American Society of Civil Engineers,  
1801 Alexander Bell Drive, Reston, VA 20191  
(www.asce.org)

ASTM E2349-2012, Standard Practice for Safety  
Requirements in Metal Casting Operations: Sand  
Preparation, Molding, and Core Making; Melting and  
Pouring; and Cleaning and Finishing  
Publisher: ASTM International, 100 Barr Harbor Drive,  
West Conshohocken, PA 19428-2959 (www.astm.org)

CMAA Specification No. 70-2010, Specifications for Top  
Running Bridge & Gantry Type Multiple Girder  
Electric Overhead Traveling Cranes — No. 70

Publisher: Crane Manufacturers Association of America,  
Inc. (CMAA), 8720 Red Oak Boulevard, Charlotte,  
NC 28217 (www.mhi.org/cmaa)

ISO 7000:2014, Graphical symbols for use on equip-  
ment — Registered Symbols  
ISO 7296-1:1991 (R2012) Cranes — Graphical symbols

Publisher: International Organization for  
Standardization (ISO), Central Secretariat, Chemin de  
Blandonnet 8, Case Postale 401, 1214 Vernier, Geneva,  
Switzerland (www.iso.org)



آریا ایمن آوات





## Chapter 18-1

# General Construction and Installation

### SECTION 18-1.1: MARKING

#### 18-1.1.1 Rated Load Markings — Crane

The rated load of the stacker crane and its load center location shall be marked on the crane. The rated load of the stacker crane shall also be marked on each side of the crane and shall be legible from the ground or floor.

#### 18-1.1.2 Manufacturer's Identification Markings

The stacker crane shall be marked with the manufacturer's identification information on a plate or label attached to the crane, as follows:

- (a) name and address of manufacturer
- (b) manufacturer's model or serial number
- (c) voltage of AC or DC power supply, and phase and frequency of AC power supply
- (d) circuit ampacity

#### (16) 18-1.1.3 Warnings

(a) Floor-operated cranes and remote-operated cranes shall have safety label(s) affixed to the pendant station, portable operating station, or the stacker crane carriage. Cab-operated and pulpit-operated stacker cranes shall have safety label(s) affixed in the cab or pulpit. The label or labels shall be in compliance with ANSI/NEMA Z535.4, and shall include cautionary language against, but not limited to

- (1) lifting more than the rated load
  - (2) operating stacker crane when the load is not properly centered on forks
  - (3) operating hoist-powered stacker with twisted, kinked, or damaged chain or rope
  - (4) operating damaged or malfunctioning stacker crane
  - (5) lifting people, except as outlined in para. 18-3.3.2(d)
  - (6) lifting loads over people
  - (7) operating a rope hoist powered stacker with a rope that is not properly seated in its groove
  - (8) removing or obscuring safety labels
- (b) A safety label shall be affixed on all electrical control enclosures. The label shall be in compliance with ANSI/NEMA Z535.4, and shall include, but not be limited to, information such as

- (1) Disconnect power and lockout disconnecting means before removing cover or servicing this equipment.
- (2) Do not operate without cover in place.

#### 18-1.1.4 Translations of Safety-Related Information and Control Designations (16)

(a) Translation of non-English documentation into English

(1) The wording of written non-English safety information and manuals regarding use, inspection, and maintenance shall be translated into English by professional translation industry standards, which include, but are not limited to

- (-a) translation of the complete paragraph message, instead of word by word
- (-b) grammatical accuracy
- (-c) respectfulness of the source document content without omitting or expanding the text
- (-d) translation of the terminology with accuracy
- (-e) reflection of the level of sophistication of the original document

(2) The finished translation shall be verified for compliance with paras. 18-1.1.4(a)(1)(-a) through 18-1.1.4(a)(1)(-e), by a qualified person having an understanding of the technical content of the subject matter.

(3) Pictograms used to identify controls shall be described in the manuals. The pictograms should comply with ISO 7000, ISO 7296, or other recognized sources, if previously defined. The text of the description shall meet the criteria of paras. 18-1.1.4(a)(1) and 18-1.1.4(a)(2).

(b) Any non-English documentation provided in addition to English shall be translated and reviewed in accordance with the requirements listed above.

### SECTION 18-1.2: CLEARANCES

#### 18-1.2.1 Clearance From Obstruction

(a) Clearance shall be maintained between the stacker crane and the building as well as parallel running cranes under all normal operating conditions. Factors that influence clearance, such as wheel float, truss sag, bridge skewing, stacker mast movement, aisle width, and approaches of the stacker trolley, shall be considered.

(b) Where passageways or walkways are provided on the structure supporting the stacker crane, obstructions shall not be placed such that personnel will be jeopardized by movements of the crane.



### Clearance Between Noninterlocking Parallel Cranes

If the runways of two cranes are parallel and there are no intervening walls or structures, there should be a minimum of 2 in. (50 mm) clearance provided and maintained between the two stacker crane bridges.

#### SECTION 18-1.3: GENERAL CONSTRUCTION — RUNWAYS AND SUPPORTING STRUCTURES

##### (16) 18-1.3.1 Foundations and Anchorages

(a) Permanent concrete or masonry foundations shall rest on footings below the frost line except in permafrost.

(b) Every outdoor stacker crane shall be provided with secure fastenings convenient to apply and able to hold the crane against a wind pressure of 30 lb/ft<sup>2</sup> (1 436 Pa). Parking brakes may be considered minimum compliance with this rule.

(c) Where design wind pressures in excess of 30 lb/ft<sup>2</sup> (1 436 Pa) are specified, special anchorages such as latches or tie-downs shall be provided at the home position, or remotely operated rail clamps capable of engagement at all positions shall be provided as a supplement to the primary braking system. (ASCE/SEI 7 may be used as a reference for this condition.)

(d) Rail clamps should only be applied when the stacker crane is not in motion.

(e) When rails are used for anchorages, they shall be secured to withstand the resultant forces applied by the rail clamps. If the clamps act on the rail, any projection or obstruction in the clamping area shall be avoided.

(f) A wind-indicating device shall be provided for all outdoor cranes. The device shall be mounted on the crane or the crane runway structure and shall give a visible and audible alarm to the crane operator at a predetermined wind velocity. A single wind-indicating device may serve as an alarm for more than one crane.

##### (16) 18-1.3.2 Crane Runways

###### (a) Construction of Runways and Rails

(1) The crane runways and supporting structures shall be designed to withstand the loads and forces imposed by the stacker crane, and should conform to the design parameters as specified in the applicable AISC Steel Construction Manual.

(2) Runway columns shall be securely anchored to foundations.

(3) The structure shall be free from detrimental vibration under normal operating conditions.

(4) Rails shall be level, straight, joined, and spaced to crane span within the manufacturer's recommended tolerances compatible with the design of the stacker crane.

###### (b) Runway Stops

(1) Stops shall be provided at the limits of travel of the stacker crane bridge.

(2) Stops shall be designed to withstand the forces applied to the bumpers as specified in para. 18-1.7.2.

(3) If a stop engages the tread of the wheel, it shall not be of a height less than the radius of the wheel. Stops engaging other parts of the stacker crane are recommended.

#### SECTION 18-1.4: STACKER CRANE CONSTRUCTION

##### 18-1.4.1 Welded Construction

All welding procedures and welding operator qualifications to be used on load-sustaining members shall be in accordance with ANSI/AWS D1.1 except as modified by ANSI/AWS D14.1. Where special steels or other materials are used, the manufacturer shall provide welding procedures.

##### 18-1.4.2 Bridge Structure

All stacker cranes built after the issuance of this Volume should conform to the minimum design parameters as specified in applicable sections of CMAA No. 70 or ANSI MH27.1.

##### 18-1.4.3 Molten Metal

Stacker cranes used for transporting or pouring molten metals shall be designed, constructed, installed, tested, maintained, and operated in accordance with this Volume and the additional requirements established by ASTM E2349.

##### 18-1.4.4 Modifications

Stacker cranes may be modified or rerated provided such modifications and the supporting structures are analyzed thoroughly by a qualified person or manufacturer of stacker cranes. A rerated stacker crane or one whose load-supporting components have been modified shall be tested in accordance with para. 18-2.2.2. The new rated load shall be displayed in accordance with para. 18-1.1.1.

#### SECTION 18-1.5: CABS

##### 18-1.5.1 Cab Construction

(a) The structure should be of noncombustible materials.

(b) Cab location generally will put the operator close to other objects; thus, special consideration should be given to confinement in the cab by screening.

(c) Outdoor cabs should be enclosed. All cab glazing shall be safety-glazing material as defined in ANSI Z26.1.

(d) Construction shall offer protection from falling objects. The protection shall support a minimum static load of 50 lb/ft<sup>2</sup> (2.4 kPa).



Door shall be interlocked so crane motions commence until the door is closed.

Electrically traveling stacker cabs shall be equipped with a device(s) to minimize free-fall in the event of malfunction of cab support hoist ropes or hoist machinery.

#### (16) 18-1.5.2 Access to Stacker Crane

Access to the stacker crane cab or bridge walkway shall be by a fixed ladder, stairs, or platform requiring no step over any gap exceeding 12 in. (305 mm). Fixed ladders shall be in conformance with ANSI-ASC A14.3.

#### 18-1.5.3 Tool Box

If a receptacle is provided for the stowing of tools and oil cans, it shall be metal and securely fastened in the cab or on the walkway.

#### 18-1.5.4 Fire Extinguisher

A portable fire extinguisher, with a basic minimum extinguisher rating of 10 BC, shall be installed in the cab or at the machinery housing.

#### 18-1.5.5 Lighting

Cab lighting, either natural or artificial, shall provide a level of illumination that enables the operator to observe the operating controls.

### SECTION 18-1.6: FOOTWALKS AND LADDERS

#### 18-1.6.1 Location of Footwalks

(a) A footwalk should be provided on the drive side along the entire length of the bridge of all stacker cranes having the trolley running on the top of the girders. To give access to the opposite side of the trolley, bridge conductors, or other equipment, there should be provided a footwalk mounted on the trolley, a footwalk or platform in the building, or a footwalk on the opposite side of the bridge at least twice the length of the trolley.

Footwalks should be located to give a headroom of not less than 78 in. (1 981 mm). In no case shall less than 48 in. (1 219 mm) be provided. If 48 in. (1 219 mm) of headroom cannot be provided, footwalks should be omitted from the stacker crane and a stationary platform or landing stage built for workers making repairs.

(b) On other than cab-operated cranes, a footwalk or other means (including mobile equipment or measures to protect workers from the hazard of falls) should be provided for workers to make repairs and inspect the crane.

#### 18-1.6.2 Construction of Footwalks

(a) Footwalks shall be designed to sustain a distributed load of at least 50 lb/ft<sup>2</sup> (2.4 kPa).

(b) Footwalks shall have a slip-resistant walking surface.

(c) Footwalks should have a clear passageway at least 18 in. (457 mm) wide except opposite the bridge crane drive mechanism and controls, where they should be not less than 15 in. (380 mm).

#### 18-1.6.3 Toeboards and Handrails for Footwalks

Toeboards and handrails shall be in compliance with ANSI A1264.1.

#### 18-1.6.4 Ladders and Stairways

(a) Stacker cranes should be provided with ladders or stairways extending from the runway elevation to the footwalk or cab platform.

(b) Stairways shall be equipped with metal handrails and should be at an angle of not more than 50 deg with the horizontal. Walking surfaces shall be of a slip-resistant type.

(c) Ladders shall be fastened in place and shall be constructed in compliance with ANSI-ASC A14.3.

#### 18-1.6.5 Egress

There should be means of egress from cab-operated stacker cranes to permit departure under emergency conditions. The means of egress should depend on the facts of the situation.

### SECTION 18-1.7: STOPS, BUMPERS, RAIL SWEEPS, AND GUARDS

#### 18-1.7.1 Trolley Stops

(a) Stops shall be provided at the limits of travel of the stacker trolley.

(b) Stops shall be designed to withstand the forces applied to the bumpers as specified in para. 18-1.7.3.

(c) If a stop engages the tread of the wheel, it shall not be of a height less than the radius of the wheel. Stops engaging other parts of the stacker crane trolley are recommended.

#### 18-1.7.2 Bridge Bumpers (Buffers)

(a) A stacker crane shall be provided with bumpers or other automatic means providing equivalent effect. These bumpers shall have the following minimum characteristics:

(1) have energy-absorbing (or -dissipating) capacity to stop the stacker crane and the rated load when it is traveling with power off in either direction at a speed of at least 40% of rated load speed

(2) be capable of stopping the stacker crane, including the vertically guided lifted load, at a rate of deceleration not to exceed an average of 3 ft/sec<sup>2</sup> (0.9 m/s<sup>2</sup>) when it is traveling with power off in either direction at 20% of rated load speed

(3) be so mounted that there is no direct shear on bolts upon impact



bumpers shall be designed and installed to minimize parts falling from the stacker crane in case of breakage or loosening of bolted connections.

(c) When more than one stacker crane is located and operated on the same runway, bumpers shall be provided on their adjacent ends to meet the requirements of paras. 18-1.7.2(a)(1), (2), and (3).

(d) Consideration shall be given to providing bumpers with greater capacity for energy absorption (or dissipation) than that specified in para. 18-1.7.2(a)(1), and to providing bridge end stops with corresponding increased strength when any one of the following conditions is present:

(1) The crane has a maximum bridge speed of 320 ft/min (100 m/min) or greater.

(2) The crane is remote operated.

(3) The crane is pulpit operated.

(4) The location of the runway end stops is obscured or uncertain. As an example, the bumper force applied at 100% of rated load speed is 625% greater than the bumper force applied at 40% of rated speed load.

### 18-1.7.3 Trolley Bumpers (Buffers)

(a) A stacker trolley shall be provided with bumpers or other automatic means of equivalent effect. These bumpers shall have the following minimum characteristics:

(1) have energy-absorbing (or -dissipating) capacity to stop the stacker trolley and the rated load when it is traveling with power off in either direction at a speed of at least 50% of rated load speed

(2) be capable of stopping the stacker trolley, including the vertically guided lifted load, at a rate of deceleration not to exceed an average of 4.7 ft/sec<sup>2</sup> (1.4 m/s<sup>2</sup>) when it is traveling with power off in either direction at one-third of rated load speed

(3) be so mounted that there is no direct shear on bolts upon impact

(b) Bumpers shall be designed and installed to minimize parts falling from the stacker trolley in case of breakage.

(c) When a bridge has more than one trolley, bumpers shall be provided on their adjacent ends to meet the requirements of paras. 18-1.7.3(a)(1), (2), and (3).

(d) Consideration shall be given to providing bumpers with greater capacity for energy absorption (or dissipation) than that specified in para. 18-1.7.3(a)(1), and to providing trolley end stops with corresponding increased strength when any one of the following conditions is present:

(1) The trolley has a maximum speed of 150 ft/min (46 m/min) or greater.

(2) The trolley is on a remote-operated crane.

(3) The trolley is on a pulpit-operated crane.

(4) The location of the trolley end stops is obscured or uncertain.

### 18-1.7.4 Rail Sweeps

(a) Bridge trucks for gantry type stacker cranes shall be equipped with sweeps that extend to the rail top, or below the rail top and project in front of the stacker crane leading wheels.

(b) Overhead top running stacker bridge trucks should be equipped with sweeps that extend below the top of the rail and project in front of the stacker crane leading wheels.

NOTE: If wheel stops are used, rail sweeps may become impractical and cannot be used.

(c) Top running stacker trolley trucks should be equipped with sweeps that extend below the top of the rail and project in front of the stacker trolley leading wheels.

NOTE: If wheel stops are used, rail sweeps may become impractical and cannot be used.

### 18-1.7.5 Wheel and Truck Frames

Means should be provided to limit the drop of stacker trolley and bridge truck frames to 1 in. (25 mm) in case of wheel or axle breakage.

### 18-1.7.6 Guards for Moving Parts

(16)

(a) Exposed moving parts such as gears, set screws, projecting keys, chains, chain sprockets, and reciprocating components that constitute a hazard under normal operating conditions shall be guarded.

(b) Each guard shall be capable of supporting, without permanent deformation, the weight of a 200 lb (90 kg) person unless the guard is located where it is not probable that a person will step on it.

## SECTION 18-1.8: BRAKES

### 18-1.8.1 Brakes for Stacker Crane Hoists

(a) Each independent hoisting unit of a stacker crane shall be equipped with at least one holding brake, applied directly to the motor shaft or some part of the gear train.

(b) Each independent hoisting unit of a stacker crane, except worm-gear hoists, the angle of whose worm is such as to prevent the load from accelerating in the lowering direction, shall, in addition to a holding brake, be equipped with control braking means to control lowering speeds.

### 18-1.8.2 Hoist Holding Brakes

(a) Holding brakes for stacker crane hoist units shall have not less than the following percentages of the rated load hoisting torque at the point where the brake is applied:

(1) 125% when used with a control braking means other than mechanical





when used with a mechanical control means

100% each if two holding brakes are provided

(b) Holding brakes on hoists shall have thermal capacity for the frequency of operation required by the service.

(c) Holding brakes on hoists shall be applied automatically when power to the brake is removed.

(d) Holding brakes shall be provided with means to compensate for lining wear.

(e) The wearing surface of all brake wheels, drums, or disks shall be free of defects that interfere with operation.

### 18-1.8.3 Hoist Controlled Braking Means

(a) An electrically controlled braking means (such as regenerative, dynamic, countertorque, or eddy current braking) or a mechanical or hydraulic controlled braking means shall be capable of maintaining controlled lowering speeds.

(b) The controlled braking means shall have thermal capacity for the frequency of operation required by the service.

### 18-1.8.4 Brakes for Stacker Crane Trolleys and Bridges (Cab Operated)

(a) Foot-operated brakes shall require an applied force of not more than 70 lb (310 N) to develop rated brake torque.

(b) Brake pedals, latches, and levers should allow release without the exertion of greater force than was used in applying the brake.

(c) Brakes may be applied by mechanical, electrical, pneumatic, hydraulic, or gravity means.

(d) Brakes shall be provided with means to compensate for lining wear.

(e) The wearing surfaces of all brakes wheels, drums, or disks shall be free of defects that interfere with operation.

(f) Foot-brake pedals shall be constructed so that the operator's foot will not readily slip off the pedal.

(g) Foot-operated brakes shall be equipped with a means for positive release when force is released from the pedal.

(h) The foot-brake pedals should be so located that they are convenient to the operator at the controls.

(i) Except for emergency braking means in para. 18-1.8.6(b), brakes for stopping the motion of the stacker crane trolley or bridge shall have the torque capability to stop the stacker crane trolley or bridge within a distance in feet (meters) equal to 10% of rated load speed in ft/min (m/min) when traveling at full speed with rated load and with power off.

NOTE: If drive friction losses result in meeting this requirement, a brake is not required.

(j) If parking brakes are provided on the stacker crane bridge or trolley(s), they shall not prohibit the use of a drift point in the control circuit.

(k) Brakes shall have thermal capacity for the frequency of operation required by the service.

### 18-1.8.5 Brakes for Stacker Crane Trolleys and Bridges (Floor and Remote Operated, Including Skeleton Cab Operated)

Brakes, if provided, shall meet the requirements of paras. 18-1.8.4(d), (e), (i), (j), and (k).

### 18-1.8.6 Stacker Crane Trolley and Bridge Braking Means

(a) Service braking means for stopping the motion of the stacker crane trolley or bridge shall have the torque capability to stop the stacker crane trolley or bridge within a distance in feet (meters) equal to 10% of rated load speed in ft/min (m/s) when traveling at full speed with rated load.

(b) Emergency braking means, when required, shall have the capability of decelerating the stacker crane trolley or bridge from rated load speed to 40% of rated load speed in the distance specified in para. 18-1.8.6(a).

NOTE: If drive friction losses result in meeting this requirement, this braking means is not required.

(c) If parking brakes are provided on the stacker crane bridge or trolley(s), they shall not prohibit the use of a drift point in the control circuit.

(d) Brake or braking means on stacker crane trolleys and bridges shall have thermal capacity for the frequency of operation required by the service.

(e) Any combination of service, emergency, and parking functions may be provided by a single friction brake as long as it can be applied without having power available.

### 18-1.8.7 Application of Stacker Crane Trolley Brakes

(a) On cab-operated stacker cranes with a cab on the trolley, a trolley service brake shall be required as specified under para. 18-1.8.4.

(b) If a brake is provided on a stacker crane trolley that does not have a cab on the trolley, it should have a torque rating of not less than 50% of the rated motor torque at the point of application.

(c) On cab-operated stacker cranes with a cab on the bridge, a drag brake may be applied to hold the trolley in a desired position on the bridge and to eliminate creep with the power off.

(d) On all floor-, remote-, and pulpit-operated stacker crane trolley drives, an emergency brake with torque rating per para. 18-1.8.6(b), a drag brake, or a noncoasting mechanical drive should be provided.

### 18-1.8.8 Application of Stacker Crane Bridge Brakes

(a) On cab-operated stacker cranes with a cab on the bridge, a service brake shall be required as specified in para. 18-1.8.6.



(b) Cab-operated stacker cranes with a cab on the bridge shall have a bridge brake of the emergency type, in addition to the emergency stop service or controlled braking means, shall be required. This brake shall comply with para. 18-1.8.6(b).

(c) On all floor-, remote-, and pulpit-operated stacker crane bridge drives, an emergency brake or noncoasting mechanical drive shall be provided to meet the requirements of para. 18-1.8.6(b).

## SECTION 18-1.9: ELECTRICAL EQUIPMENT

### 18-1.9.1 General

(a) Wiring and equipment shall comply with Article 610 of ANSI/NFPA 70.

(b) The control circuit voltage in pendant push buttons or to cab-operated controllers shall not exceed 150 V for AC or 300 V for DC.

(c) Where multiple conductor cable is used with a suspended push-button station, the station shall be supported so that the electrical conductors are protected from strain.

(d) Pendant control stations shall be constructed to prevent electrical shock. The push-button enclosure shall be at ground potential.

(e) Control actuators shall be labeled indicating their function and resulting direction of motion.

### 18-1.9.2 Equipment

(a) Electrical equipment shall be so located or enclosed that live parts will not be exposed to inadvertent contact under normal operating conditions.

(b) Live parts of electrical equipment shall be protected from direct exposure to grease, oil, and moisture, and they should be protected from dirt.

(c) Guards for live parts, if provided, shall be so constructed or located that they cannot be inadvertently deformed so as to make contact with the live parts.

### 18-1.9.3 Controllers

(a) Stacker cranes not equipped with spring-return controllers, spring-return master switches, or momentary contact push buttons shall be provided with a device which will disconnect all motors from the line in the event of a power failure. This disconnect device shall not permit any motor to be restarted until the controller or master switch handle is brought to the off position, or a reset switch or "power on" button is operated.

(b) Lever-operated manual controllers and master switches shall be provided with a notch or latch, which in the off position, prevents the handle from being inadvertently moved to the on position. An off detent, or spring-return arrangement, is acceptable.

(c) For cab-operated cranes, the master switch operating mechanism shall be located within reach of the operator.

(d) For cab- or pulpit-operated stacker cranes, the movement of each operating handle should be in the same general direction as the resultant movement of the load, except as shown in Figs. 18-1.9.3-1 and 18-1.9.3-2.

(e) For cab- or pulpit-operated stacker cranes, the arrangement of manual controllers or master switches should conform to Figs. 18-1.9.3-1 and 18-1.9.3-2.

(f) If a magnet controller is provided, the on (lift) direction shall be toward the operator and off (drop) direction away from the operator.

(g) For floor-operated stacker cranes, the controller or controllers, if rope-operated, shall automatically return to the off position when released by the operator.

(h) Push buttons in pendant stations shall return to the off position when pressure is released by the crane operator.

(i) Remote-operated stacker cranes shall function so that if the control signal for any crane motion becomes ineffective, that crane motion shall stop, and conversely, signals received from any source other than the operating station (transmitter) shall not result in operation of any motion of the stacker crane.

(j) The arrangement of pendant push-button stations and radio-control transmitters should conform to Figs. 18-1.9.3-3 and 18-1.9.3-4, respectively. Compass directions may be substituted for "right-left" and "forward-reverse" in Fig. 18-1.9.3-3, and for W, X, Y and Z in Fig. 18-1.9.3-4.

(k) Master switches shall be labeled to indicate their functions.

### 18-1.9.4 Resistors

(a) Resistor units, when used, shall be supported to minimize vibration effect.

(b) Provisions shall be made to prevent broken parts or molten metal falling upon the operator or from the crane.

(c) If resistor enclosures are provided, the enclosures shall be installed to minimize the accumulation of combustible matter.

### 18-1.9.5 Switches

(a) The power supply to the runway conductors shall be controlled by a switch or circuit breaker located on a fixed structure, accessible from the floor, and arranged to be locked in the open position.

(b) On cab-operated stacker cranes, a switch or circuit breaker of the enclosed type with provision for locking in the open position shall be provided in the leads from the runway conductors. A means of opening this device shall be located within the reach of the operator when the operator is in the operating position. When the operator opens this switch or circuit breaker, the holding brake(s) should set.

(c) On floor-, remote-, or pulpit-operated stacker cranes, a switch or circuit breaker of the enclosed type

**Fig. 18-1.9.3-1 Recommended Arrangement of Controllers or Master Switches (Three-Motor Crane)**

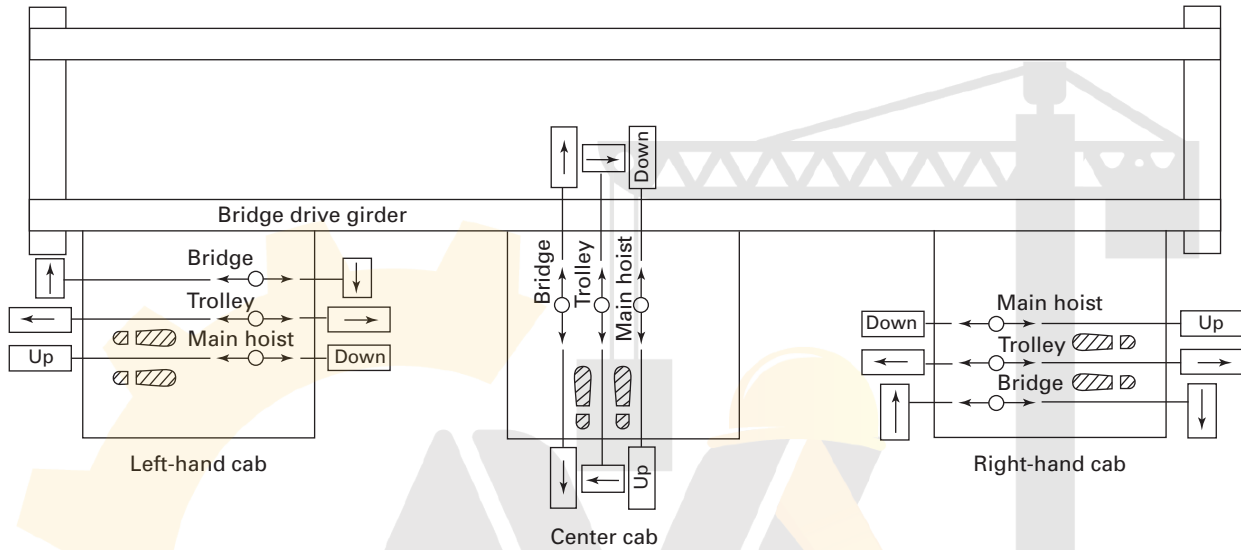

**Fig. 18-1.9.3-2 Recommended Arrangement of Controllers or Master Switches (Four-Motor Crane)**

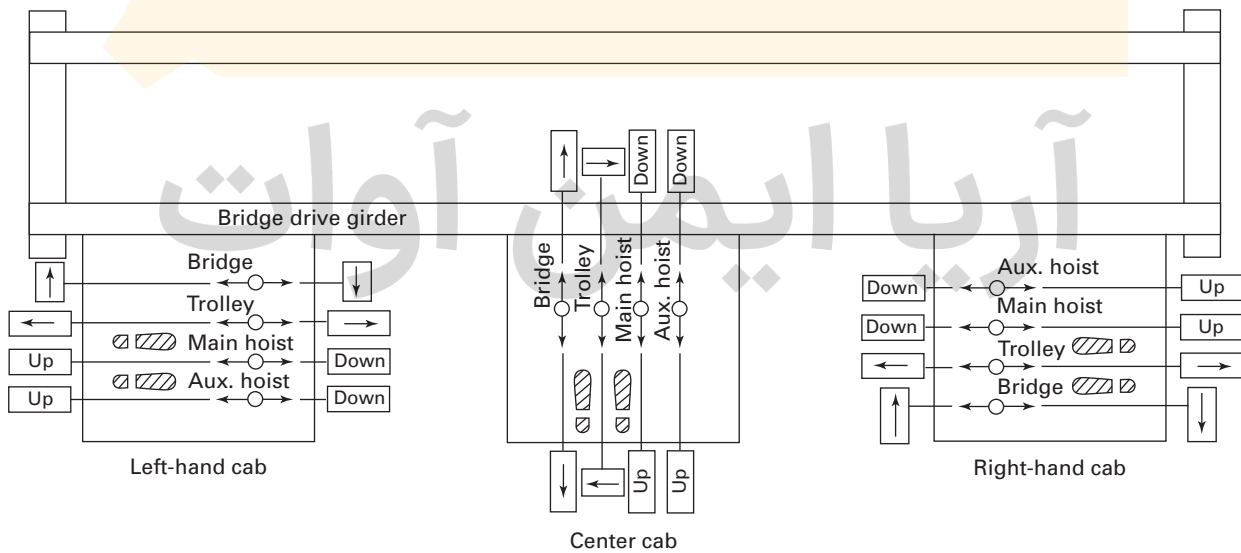
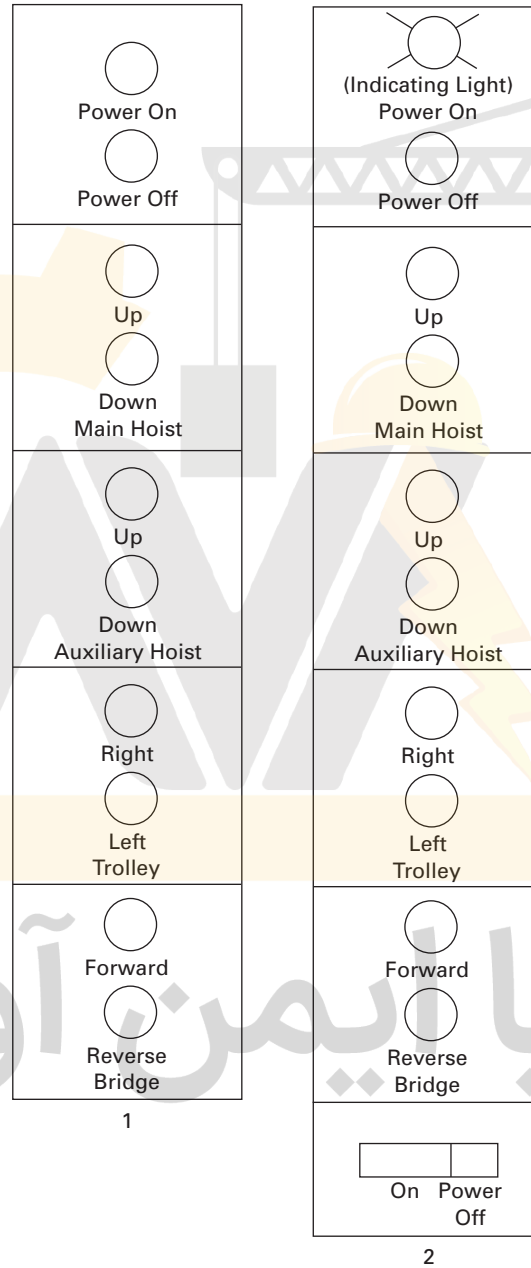
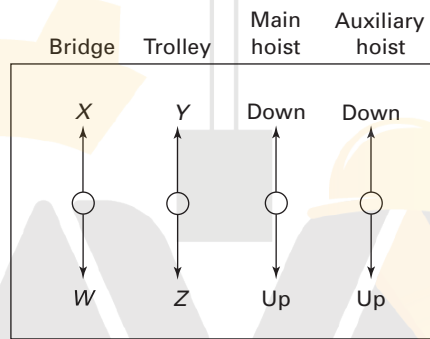

Fig. 18-1.9.3-3 Recommended Arrangement of Controllers (Pendant Push-Button Station Arrangement)



GENERAL NOTE: In each user location, the relative arrangement of units on crane pendant push-button stations should be standardized. In the absence of such standardization, suggested arrangements are shown in arrangements 1 and 2.

**Fig. 18-1.9.3-4 Recommended Arrangement of Controllers  
(Radio Crane Control Transmitter Lever Arrangement)**



Four-Motion

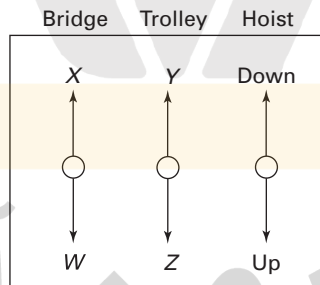

Three-Motion

آریا ایمن آوات



provided in the leads from the runway conductor. This device shall be mounted on the bridge or walk near the runway collectors. There shall be provisions for locking the device in the open position unless the stacker crane is the only load on a lockable switch or circuit breaker that is accessible from the floor. One of the following types of floor-, remote-, or pulpit-operated disconnects shall be provided:

(1) nonconductive fiber-rope attached to the main disconnect device on a floor-operated stacker crane. If this is selected, the rope shall be suspended adjacent to the operating ropes if manual controllers are used, or near the pendant push-button station if magnetic controls are used.

(2) an under voltage trip for a main circuit breaker, operated by an emergency stop button in the pendant push-button station or the pulpit.

(3) a main line contactor operated by a switch or push button on the pendant push-button station, the remote control station, or the pulpit.

(d) The hoisting motion of all electric traveling stacker cranes shall be provided with an overtravel limit switch in the hoisting direction to stop hoisting motion. On stacker cranes using a wire rope hoist, if a geared or other limit switch device that operates in relation to drum turns is used, an additional limit switch or device that operates independent of drum rotations shall be provided.

#### 18-1.9.6 Runway Conductors

Conductors of the open type, mounted on the stacker crane runway beams or overhead, shall be located or guarded so that persons cannot inadvertently come into contact with them.

#### 18-1.9.7 Extension Lamps

If a service receptacle is provided in the stacker cab or on the stacker bridge, it shall be a grounded type permanent receptacle, not exceeding 300 V.

### SECTION 18-1.10: HOISTING EQUIPMENT

#### 18-1.10.1 Sheaves

(a) Sheave grooves shall be free from surface defects that could cause rope damage. The cross-sectional radius at the bottom of the groove should be such as to form a close-fitting saddle for the size of rope used. The sides of the groove shall be tapered outward and rounded at the rim to facilitate entrance of the rope into the groove. Flange rims shall run true about the axis of rotation.

(b) Sheaves carrying ropes, which can be momentarily unloaded, shall be provided with close-fitting guards, or other devices, to guide the rope back into the groove when the load is reapplied.

(c) Means shall be provided to minimize chafing of the ropes during normal operation.

(d) All running sheaves should be equipped with means for lubrication. Permanently lubricated, sealed, or shielded bearings are acceptable.

(e) Sheave pitch diameter, in relation to rope diameter, will have an effect on the wear of the rope. Therefore, rope inspection as given in paras. 18-2.4.1, 18-2.4.2, and 18-2.4.3 shall be followed.

#### 18-1.10.2 Drums

Rope drums shall be grooved. The grooves shall be free from surface defects that could cause rope damage. The cross-sectional radius at the bottom of the groove should form a close-fitting saddle for the size of rope used.

#### 18-1.10.3 Rope

(a) The hoisting ropes shall be of a recommended construction for stacker crane service. The total load (rated load + weight of carriage) divided by the number of parts of line shall not exceed 20% of the minimum breaking force of the rope.

(b) Socketing shall be done in the manner specified by the manufacturer of the hoist rope assembly or the rope manufacturer.

(c) Rope shall be secured to the drum as follows:

(1) No less than two wraps of rope shall remain on each anchorage of the hoisting drum when the carriage is in its extreme low position unless a lower limit device is provided, in which case no less than one wrap shall remain.

(2) Rope end shall be anchored by a clamp attached to the drum, or by a socket arrangement specified by the crane or rope manufacturer. The rope clamps shall be tightened evenly to the manufacturer's recommended torque.

(d) Eye splices shall be made in a recommended manner. Rope thimbles should be used in the eye.

(e) Wire-rope clips shall be drop-forged steel of the single saddle (U-bolt) or double saddle type clip. Malleable cast iron clips shall not be used. For spacing, number of clips, and torque values, refer to the clip manufacturer's recommendation. Wire-rope clips attached with U-bolts shall have the U-bolt over the dead end of the rope and the live rope resting in the clip saddle. Clips shall be tightened evenly to the recommended torque. After the initial load is applied to the rope, the clip nuts shall be retightened to the recommended torque to compensate for any decrease in rope diameter caused by the load. Rope clip nuts should be retightened periodically to compensate for any further decrease in rope diameter during usage.

(f) Swaged or compressed fittings shall be applied as recommended by the rope, stacker crane, or fitting manufacturer.





...ver exposed to ambient temperatures at the  
...ss of 180°F (82°C), rope having an indepen-  
...re-rope or wire-strand core, or other  
temperature-damage resistant core shall be used.

(h) Replacement rope shall be the same size, grade, and construction as the original rope furnished by the stacker crane manufacturer, unless otherwise recommended by a rope or stacker crane manufacturer or qualified person due to actual working condition requirements.

#### 18-1.10.4 Equalizers

If a load is supported by more than one part of rope, the tension in the parts shall be equalized.

#### 18-1.10.5 Guards for Hoisting Ropes

(a) If it is possible for hoisting ropes to foul or chafe on adjacent parts of the stacker crane under normal

operating conditions, guards shall be installed to minimize damage to the rope.

(b) A guard shall be provided to prevent contact between bridge or runway conductors and hoisting ropes if, under normal operating conditions, they can come into contact.

#### SECTION 18-1.11: WARNING DEVICES

On cab- and remote-operated stacker cranes, an audible or visual warning means shall be provided.

#### SECTION 18-1.12: LUBRICATION

Lubricating points should be accessible from walkways, floors, or platforms.

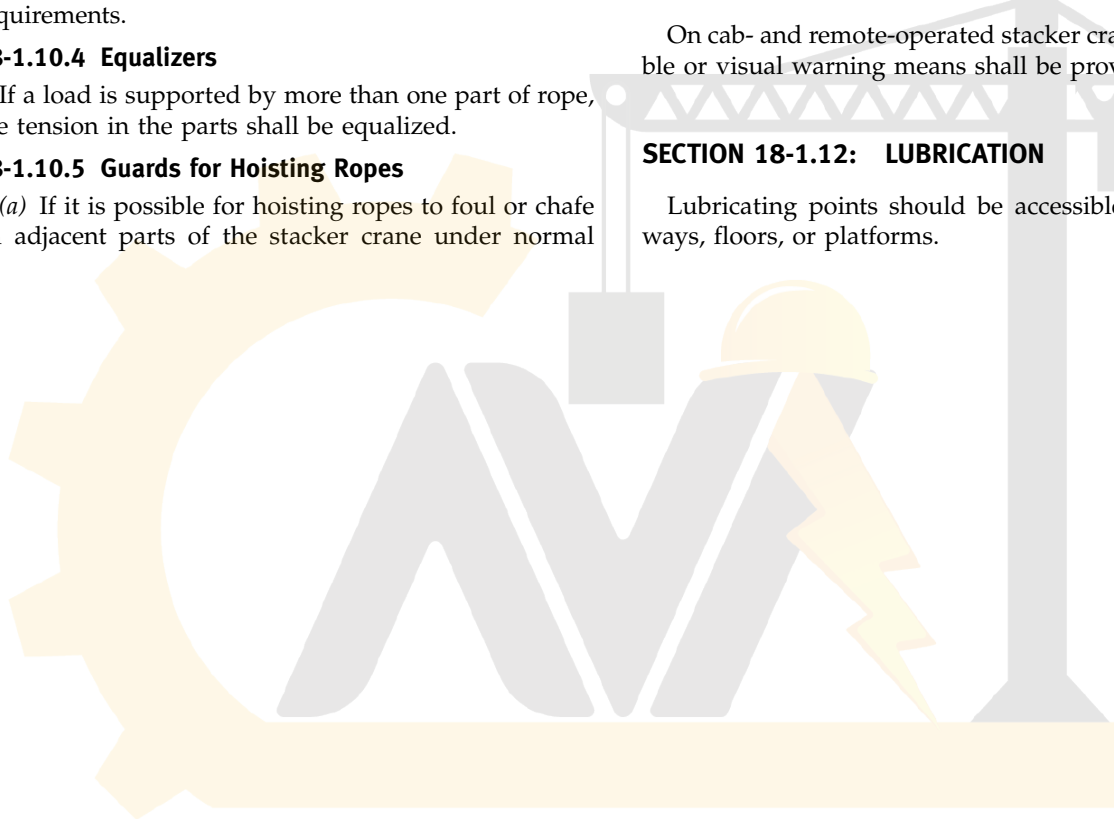

# آریا ایمن آوات



## Chapter 18-2 Inspection, Testing, and Maintenance

### SECTION 18.2.1: INSPECTION

#### (16) 18-2.1.1 General

All inspections shall be performed by a designated person. Any deficiencies identified shall be examined and a determination made by a qualified person as to whether they constitute a hazard, and if so, what additional steps need to be taken to address the hazard.

#### (16) 18-2.1.2 Inspection Classification

(a) *Initial Inspection.* Prior to initial use, all new, reinstalled, altered, modified, or extensively repaired stacker cranes shall be inspected by a designated person to verify compliance with the applicable provisions of this Volume.

(b) Inspection procedures for stacker cranes in regular service is divided into two general classifications based upon the intervals at which inspection should be performed. The intervals in turn are dependent upon the nature of the critical components of the stacker crane and the degree of their exposure to wear, deterioration, or malfunction. The two general classifications are designated as *frequent* and *periodic* with respective intervals between inspections as defined below.

(1) *Frequent Inspection.* Visual inspections with records not required.

(-a) normal service: monthly

(-b) heavy service: weekly to monthly

(-c) severe service: daily to weekly

(-d) special or infrequent service: recommended by a qualified person before and after each instance of special or infrequent service

(2) *Periodic Inspection.* Visual inspection of apparent external conditions, with records kept, to provide the basis for a continuing evaluation.

(-a) normal service, equipment in place: yearly

(-b) heavy service, equipment in place: quarterly, unless external conditions indicate that disassembly should be done to permit detailed inspection

(-c) severe service, equipment in place: quarterly, unless external conditions indicate that disassembly should be done to permit detailed inspection

(-d) special or infrequent service: recommended by a qualified person before and after each instance of special or infrequent service

#### 18-2.1.3 Frequent Inspection

(a) Frequent inspections shall be performed at intervals defined in para. 18-2.1.2(b)(1) and shall include observations during operation.

(b) Determination shall be made whether conditions found during the inspection constitute a hazard and whether a more detailed inspection is required.

(c) The following items shall be inspected:

(1) all functional operating mechanisms for maladjustment interfering with proper operation

(2) operation of upper limit device(s) shall be verified in accordance with para. 18-3.3.3(a)

(3) lines, tanks, valves, pumps, and other parts of pneumatic or hydraulic systems for leakage

(4) rated load supporting devices attached to the carriage

(5) hoist ropes, including end fittings, rope clips, and proper seating in sheaves and drums

(6) free fall stop(s)

#### 18-2.1.4 Periodic Inspection

(16)

Complete inspection of the stacker cranes shall be performed at intervals as defined in para. 18-2.1.2(b)(2). Any deficiencies, such as those listed, shall be examined and determination made as to whether they constitute a hazard. These inspections should include the requirements of para. 18-2.1.3 and, in addition, items such as the following:

(a) deformed, cracked, or corroded members.

(b) loose bolts or rivets.

(c) cracked or worn sheaves and drums.

(d) worn, cracked, or distorted parts such as pins, bearings, shafts, gears, rollers, and locking and clamping devices.

(e) excessive wear on brake system parts, linings, pawls, and ratchets.

(f) load and other indicators over their full range for any significant inaccuracies.

(g) excessive wear of chain drive sprockets and excessive chain stretch.

(h) electrical apparatus for signs of any deterioration of controllers, master switches, contacts, limit switches, and push-button stations, but not limited to these items.

(i) all limit devices should be checked, without a load on the carriage. Care shall be exercised. The carriage shall be inched into its limit device, or run in at a slow speed.





### Stacker Cranes Not in Regular Use

Stacker crane, other than a standby stacker crane, which has been idle for a period of one month or more but less than one year, shall be given an inspection conforming with the requirements of para. 18-2.1.3 before being placed in service.

(b) Standby stacker cranes shall be inspected annually in accordance with the requirements of para. 18-2.1.3. Standby stacker cranes exposed to adverse environments should be inspected more frequently.

#### (16) 18-2.1.6 Inspection Records

Dated inspection reports or comparable records shall be made on critical items such as hoisting machinery sheaves, carriage, chains, ropes, and other lifting devices as listed in para. 18-2.1.4. Records shall be available for examination.

### SECTION 18-2.2: TESTING

#### (16) 18-2.2.1 Operational Tests

(a) Prior to initial use, all new, reinstalled, altered, or modified stacker cranes shall be inspected by a designated person to ensure compliance with this Volume including the following functions:

- (1) lifting and lowering.
- (2) trolley travel.
- (3) bridge travel.

(4) limit switches. The trip setting of hoist limit devices shall be determined by tests with an empty carriage traveling in increasing speeds up to the maximum speed. The actuating mechanism of the limit device shall be located so that it will trip the device under all conditions, in sufficient time to prevent contact of the carriage or load block with any part of the trolley mast support or stacker crane.

(5) locking, limiting, and indicating devices, if provided.

(b) Prior to initial use, a repaired stacker crane shall be tested. Testing may be limited to the functions affected by the repair.

#### 18-2.2.2 Rated Load Test

(a) Prior to initial use

(1) all new, reinstalled, altered, or modified equipment shall be tested and inspected by or under the direction of a designated person. A written test report shall be prepared by the designated person and placed on file. Test loads shall be  $125\% \pm 5\%$  of the rated load, unless otherwise recommended by the manufacturer.

(2) the need for testing of repaired equipment shall be determined by a qualified person. When a rated load test is required, testing shall be in accordance with para. 18-2.2.2(a)(1).

(b) The rated load test, if made, shall consist of the following operations as a minimum requirement:

(1) Hoist the carriage and test load a distance to assure that the load is supported by the stacker crane and held by the hoist brake(s).

(2) Transport the test load by means of the stacker trolley for the full length of the bridge.

(3) Transport the test load by means of the bridge for the full length of the runway in one direction with the trolley as close to the extreme right-hand end of the stacker crane as practical and in the other direction with the trolley as close to the extreme left-hand end of the stacker crane as practical.

(4) Lower the carriage and test load, and stop and hold the load with the brake(s).

### SECTION 18-2.3: MAINTENANCE

#### 18-2.3.1 Preventive Maintenance

(16)

(a) A preventive maintenance program shall be established and should be based on the recommendations outlined in the crane manufacturer's manual. Dated records should be placed on file.

(b) Replacement parts shall be at least equal to the original manufacturer's specifications.

#### 18-2.3.2 Maintenance Procedure

(16)

(a) Before adjustments and repairs are started on a stacker crane, the following precautions shall be taken as applicable:

(1) The stacker crane to be repaired shall be moved to a location where it will cause the least interference with other cranes and operations in the area.

(2) All controllers shall be placed in the off position.

(3) Main switch (crane disconnect) shall be de-energized and locked, tagged, or flagged in the de-energized position.

(4) Effective markings and barriers shall be utilized in instances where maintenance work creates a hazardous area on the floor beneath the stacker crane.

(5) Where other cranes are in operation on the same runway, rail stops, or other means shall be provided to prevent interference with the idle stacker crane.

(6) Where temporary protective rail stops or other means are not available or practical, a signalperson shall be placed at a visual vantage point for observing the approach of an active stacker crane and warning its operator when reaching the limit of safe distance from the idle stacker crane.

(7) Where runways are adjacent to the stacker crane runway of the stacker crane being repaired and/or the center runway or center repair platform becomes a work area that is not protected by wire mesh or other suitable protection, or if any hazard from adjacent operations exists, the adjacent runway must also be restricted. When stacker cranes must operate on adjacent runways and



In the restricted area, a signalperson shall be provided. All stacker cranes shall come to a full stop prior to entering the restricted area and may then proceed through this area on a signal from the signalperson.

(b) Provisions shall be made for trained personnel to work on energized equipment when adjustments and tests are required.

(c) After adjustments and repairs have been made, the stacker crane shall not be restored to service until all guards have been reinstalled, safety devices reactivated, and maintenance equipment removed.

### 18-2.3.3 Adjustments and Repairs

(a) Any hazardous conditions disclosed by the inspection requirements of Section 18-2.1 shall be corrected before normal operation of the stacker crane is resumed. Adjustments and repairs shall be done only by a designated person.

(b) Adjustments shall be maintained to ensure correct functioning of components. The following are examples:

- (1) all functional operating mechanisms
- (2) limit devices
- (3) control systems
- (4) brakes

(c) Repairs or replacements shall be made as needed. The following are examples:

- (1) all critical parts that are cracked, broken, bent, or excessively worn.
- (2) pitted or burned electrical contacts should be corrected only by replacement and in sets. Controller parts should be lubricated as recommended by the manufacturer.
- (3) function labels on pendant control stations shall be kept legible.
- (d) If repairs of load sustaining members are made by welding, identification of materials shall be made and appropriate welding procedure shall be followed.

### 18-2.3.4 Lubrication

(a) All moving parts of the stacker crane, for which lubrication is specified, should be regularly lubricated. Lubricating systems should be checked for delivery of lubricant. Care should be taken to follow manufacturer's recommendations as to points and frequency of lubrication, maintenance of lubricant levels, and types of lubricant to be used.

(b) Machinery shall be stationary while lubricants are being applied, and protection provided as called for in paras. 18-2.3.2(a)(1) through (4) unless equipped for automatic or remote lubrication.

(c) Lubricants should be kept away from any grab surfaces on the vertical anti-free-fall devices.

## SECTION 18-2.4: ROPE INSPECTION, REPLACEMENT, AND MAINTENANCE

### 18-2.4.1 General

(16)

All inspections shall be performed by a designated person. Any deficiencies identified shall be examined and a determination made by a qualified person as to whether they constitute a hazard, and if so, what additional steps need to be taken to address the hazard.

### 18-2.4.2 Rope Inspection

(16)

#### (a) Frequent Inspection

(1) All ropes should be visually inspected at the start of each shift. These visual observations should be concerned with discovering gross damage, such as the following, which may be a hazard:

(-a) distortion of the rope such as kinking, crushing, unstranding, birdcaging, main strand displacement, or core protrusion

(-b) general corrosion

(-c) broken or cut strands

(-d) number, distribution, and type of visible broken wires [see paras. 18-2.4.3(b)(1) through (3) for further guidance]

(2) When such damage is discovered, the rope shall either be removed from service or given an inspection as detailed in para. 18-2.4.2(b).

#### (b) Periodic Inspection

(1) The inspection frequency shall be determined by a qualified person and shall be based on such factors as expected rope life, as determined by experience on the particular installation or similar installations, severity of environment, percentage of capacity lifts, frequency rates of operation, and exposure to shock loads. Inspections need not be at equal calendar intervals and should be more frequent as the rope approaches the end of its useful life.

(2) Periodic inspections shall be performed. This inspection shall cover the entire length of rope. The individual outer wires in the strands of the rope shall be visible to this person during the inspection. Any deterioration resulting in appreciable loss of original strength, such as the following, shall be noted and determination shall be made as to whether further use of the rope would constitute a hazard:

(-a) points listed in para. 18-2.4.2(a)

(-b) reduction of rope diameter below nominal diameter due to loss of core support, internal or external corrosion, or wear of outside wires

(-c) severely corroded or broken wires at end connections

(-d) severely corroded, cracked, bent, worn, or improperly applied end connections



Special care should be taken when inspecting for rapid deterioration such as the following:

- (a) sections in contact with saddles, equalizer sheaves, or other sheaves where rope travel is limited
- (b) sections of the rope at or near terminal ends where corroded or broken wires may protrude
- (c) sections subject to reverse bends
- (d) sections of rope that are normally hidden during visual inspection, such as parts passing over sheaves

(c) In order to establish data as a basis of judging the proper time for replacement, a continuing inspection record should be maintained. This record should cover points of deterioration listed in para. 18-2.4.2.

### (16) 18-2.4.3 Rope Replacement

(a) No precise rules can be given for determination of the exact time for rope replacement since many variable factors are involved. Once a rope reaches a specified removal criteria, it may be allowed to operate to the end of the work shift, based on the judgment of a qualified person. The rope shall be replaced after that work shift, at the end of the day, or, at the latest, prior to the equipment's use by the next work shift.

(b) Removal criteria for wire rope replacement shall be as follows:

(1) in running ropes, six randomly distributed broken wires in six-rope diameters or three broken wires in one strand in six-rope diameters, except as noted in para. 18-2.4.3(b)(2)

(2) in rotation resistant ropes, two randomly distributed broken wires in six rope diameters or four randomly distributed broken wires in thirty rope diameters

(3) one outer wire, broken at the contact point with the core of the rope that has worked its way out of the rope structure and protrudes or loops out from the rope structure

(4) kinking, crushing, birdcaging, or any other damage resulting in distortion of the rope structure

(5) evidence of heat damage from any cause

(6) reductions from nominal diameter greater than 5%

(c) Broken wire removal criteria cited in this Volume apply to wire rope operating on steel sheaves and drums. The user shall contact a qualified person, the sheave, drum, or crane manufacturer for broken wire removal criteria for wire ropes operating on sheaves and drums made of material other than steel.

(d) Attention shall be given to end connections. Upon development of two broken wires adjacent to a socketed end connection, the rope should be resocketed or replaced. Resocketing shall not be attempted if the resulting rope length will be insufficient for proper operation.

(e) Replacement rope and connections shall have a strength rating at least as great as the original rope and connections furnished by the crane manufacturer. Any deviation from the original size, grade, or construction shall be specified by a rope manufacturer, the crane manufacturer, or a qualified person.

### 18-2.4.4 Rope Maintenance

(a) Rope should be stored to prevent damage or deterioration.

(b) Unreeling or uncoiling of rope shall be done with care to avoid kinking or inducing a twist.

(c) Before cutting a rope, means shall be used to prevent unlaying of the strands.

(d) During installation, care should be observed to avoid dragging the rope in dirt or around objects that will scrape, nick, crush, or induce sharp bends.

(e) Rope should be maintained in a well-lubricated condition. Lubricant applied as part of a maintenance program shall be compatible with the original lubricant. Lubricant applied shall be of the type that does not hinder visual inspection. Those sections of rope that are located over sheaves or otherwise hidden during inspection and maintenance procedures require special attention when lubricating rope. The purpose of rope lubrication is to reduce internal friction and to prevent corrosion.



## Chapter 18-3 Operation

### SECTION 18-3.1: QUALIFICATIONS AND RESPONSIBILITIES

#### (16) 18-3.1.1 Operators

(a) Stacker cranes shall be operated only by the following personnel:

(1) designated persons.

(2) trainees under the supervision of a designated person. The number of trainees permitted to be supervised by a single designated person, the physical location of the designated person while supervising, and the type of communication required between the designated person and the trainee shall be determined by a qualified person.

(3) maintenance and test personnel, when it is necessary in the performance of their duties

(4) inspectors (stacker cranes)

(b) No one, other than personnel specified in para. 18-3.1.1(a), shall enter a stacker crane or pulpit with the exception of persons such as oilers and supervisors, whose duties require them to do so, and then only in the performance of their duties and with the knowledge of the operator or other designated person.

#### (16) 18-3.1.2 Qualifications for Operators

(a) Operators of floor-operated stacker cranes shall be required by the employer to pass a practical operating examination. Qualification shall be limited to the specific type of equipment for which examined.

(b) Operators of cab-operated, pulpit-operated, or remote-operated stacker cranes shall be required by the employer to pass a written or oral examination, and a practical operating examination unless able to furnish satisfactory evidence of qualifications and experience, in which case only a practical operating examination shall be required. Qualification shall be limited to the specific type of equipment for which examined.

(c) Operators and operator trainees shall meet the following physical qualifications:

(1) vision of at least 20/30 Snellen in one eye, and 20/50 in the other, with or without corrective lenses

(2) ability to distinguish colors regardless of position of colors, if color differentiation is required for operation

(3) hearing, with or without hearing aid, must be adequate for a specific operation

(4) sufficient strength, endurance, agility, coordination, and speed of reaction to meet the demands of equipment operation

(5) normal depth perception, field of vision, reaction time, manual dexterity, coordination, and no tendencies to dizziness or similar undesirable characteristics

(d) Evidence of physical defects or emotional instability that could render the operator a hazard to the operator or others, or in the opinion of the examiner could interfere with the operator's performance, may be cause for disqualification. In such cases, specialized clinical or medical judgments and tests may be required.

(e) Evidence that an operator is subject to seizures or loss of physical control shall be reason for disqualification. Specialized medical tests may be required to determine these conditions.

#### 18-3.1.3 Responsibilities

(16)

While the organizational structure of various workplaces may differ, the following roles are described for the purpose of delineating responsibilities. All responsibilities listed below shall be assigned in the workplace organization. (A single individual may perform one or more of these roles.)

*crane owner:* has custodial control of the crane by virtue of lease or ownership.

*supervisor:* exercises supervisory control over the crane operator, the facility, or the work area where the crane is being used.

*crane operator:* directly controls the crane's functions.

(a) The crane owner's responsibilities shall include the following:

(1) providing a stacker crane that meets the requirements of Chapters 18-1 and 18-2 of this Volume

(2) providing a stacker crane and all necessary components, specified by the manufacturer, that meets the required configuration and capacity for its intended use

(3) establishing an inspection, testing, and maintenance program in accordance with Chapter 18-2

(4) designating personnel for the purposes of maintenance, repair, inspection, and testing

(5) establishing qualification examinations as specified in para. 18-3.1.2





Supervisor's responsibilities shall include the ensuring that all inspection, testing, and maintenance programs are followed

(2) using crane operators that meet the requirements of para. 18-3.1.2

(3) ensuring the assigned operator(s) has been notified of adjustments or repairs that have not yet been completed, prior to commencing crane operations

(4) complying with the requirements of this Volume, manufacturer's requirements, and those regulations applicable in the workplace

(c) The crane operator's responsibilities shall include the items listed in Sections 18-3.2 and 18-3.3 of this Volume.

## (16) SECTION 18-3.2: CONDUCT OF OPERATORS

(a) The operator shall not engage in any practice that will divert attention while actually engaged in operating the stacker crane.

(b) When physically or otherwise unfit, an operator shall not engage in the operation of the stacker crane.

(c) Each operator shall be responsible for those operations under the operator's direct control. Whenever there is doubt as to safety, the operator shall consult with the supervisor before handling the loads.

(d) If a warning device is furnished, it shall be activated each time before traveling, and intermittently when approaching workpersons.

(e) Before leaving a cab-operated stacker crane unattended, the operator shall land the load, place controllers in the off position, and open the main line disconnect device of the specific stacker crane.

(f) The operator shall not close the main line disconnect device until certain that no worker is on or adjacent to the stacker crane. If there is a warning sign or lock on the device, it shall not be energized until the sign or lock is removed by the person who placed it there, or by a designated person.

(g) Before closing the main line disconnect device, the operator shall see to it that all controllers are in the off position.

(h) If power goes off during operation, the operator shall immediately place all controllers in the off position. Prior to reuse of the stacker crane, operating motions shall be checked for proper direction.

(i) The operator shall be familiar with the equipment and its proper care. If adjustments or repairs are necessary, or any defects are known, the operator shall report the same promptly to the designated person who shall be responsible for the operation and maintenance repairs of the stacker crane. The operator shall also notify the next operator or shift supervisor of any remaining uncorrected deficiencies upon changing shifts.

(j) Contacts with runway stops or other stacker cranes shall be made with caution. The operator shall do so with care for the safety of persons on or below the stacker crane, and only after making certain that any persons on the other stacker cranes are aware of what is being done.

(k) Operators of outdoor stacker cranes shall secure them when leaving.

(l) When the wind-indicating alarm is given, the bridge or gantry on outside stacker cranes shall be anchored.

(m) Before the operator performs any maintenance work on the stacker crane, the operator shall lock, tag, or flag the main switch (see para. 18-2.3.2) in the de-energized position.

(n) All controls shall be tested by the operator before beginning a new shift. If any controls do not operate properly, they should be adjusted or repaired before operations are begun.

(o) Persons boarding or leaving overhead stacker cranes should do so only at authorized locations and designated boarding entrances.

## SECTION 18-3.3: HANDLING THE LOAD

### 18-3.3.1 Load Weight

The crane shall not be loaded beyond its rated load except for test purposes as provided in para. 18-2.2.2.

### 18-3.3.2 Moving the Load

(a) The operator shall determine that

(1) the load is supported on the lifting device on the carriage

(2) the load is balanced (centered) and positioned on the lifting device on the carriage before the load is lifted more than a few inches (millimeters)

(3) the rope is seated in the drum grooves and in the sheaves, if there is or has been a slack rope condition

(b) During lifting, care shall be taken that

(1) there is no sudden acceleration or deceleration of the moving load

(2) the load does not contact any obstructions

(c) Stacker cranes shall not be used for side pushing or pulling of loads.

(d) The operator shall not lift, lower, or travel while anyone is on the carriage outside the cab, except as is necessary for maintenance, inspection, or inventory checks. Prior to any such use, the following shall be verified:

(1) the rider is secured by a fall protection system

(2) a flat, slip-resistant surface upon which to stand shall be provided either on the carriage or on a portable platform/surface attached to the carriage

(3) travel is in the jog control mode

(4) the controls shall be operated by a designated operator

(5) the operator and rider are able to communicate



(7) A means of emergency stop shall be available to person on the carriage

(7) hand hold(s) shall be available to the person(s) on the carriage

(e) The operator should avoid carrying loads over people.

(f) The operator shall check the hoist brake(s) at least once each shift if a load approaching the rated load is to be handled. This shall be done by lifting the load a short distance and applying the brake(s).

(g) The load shall not be lowered below the point where two wraps of rope remain on each anchorage of the hoisting drum unless a lower limit device is provided, in which case no less than one wrap shall remain.

#### (16) 18-3.3.3 Hoist Limit Devices (Switches)

(a) Prior to the initial use of any hoist during each shift, the operator shall verify operation of the primary upper limit device of that hoist under no load conditions. Care shall be exercised; the carriage shall be inched into the limit or run in at slow speed. If the device does not operate properly, the operator shall immediately notify the shift supervisor or other designated person.

(b) The hoist limit device that controls the upper limit of travel of the carriage shall not be used as an operating control in normal operation unless additional means are provided to prevent damage from overtravel.

### SECTION 18-3.4: MISCELLANEOUS

#### 18-3.4.1 Ladders

(a) Hands shall be free from encumbrances while personnel are using ladders.

(b) Articles that are too large to be carried in pockets or tool belts shall be lifted and lowered by hand line.

#### 18-3.4.2 Cabs

(a) Clothing and personal belongings shall be stored in such a manner as to not interfere with access or operation.

(b) Tools, oil cans, rags, and other articles shall not be permitted to lie loose in or about the cab.

#### 18-3.4.3 Fire Extinguishers

Operators shall be familiar with the location, operation, and care of fire extinguishers provided. (Refer to para. 18-1.5.4.)

#### 18-3.4.4 Crane Lockout/Tagout

(16)

(a) A lockout/tagout policy and procedure shall be developed, documented, and implemented by the owner or user of stacker cranes.

(b) The lockout/tagout policy and procedure shall comply with the requirements of ANSI/ASSE Z244.1.

(c) The policy shall give consideration to the following areas:

- (1) single-crane runways
- (2) multiple-crane runways
- (3) cranes on an adjacent runway
- (4) runway disconnecting means
- (5) crane disconnecting means
- (6) work to be done on a crane
- (7) work to be done other than on a crane but within the path of a crane where its movement creates a hazard

آریا ایمن آوات

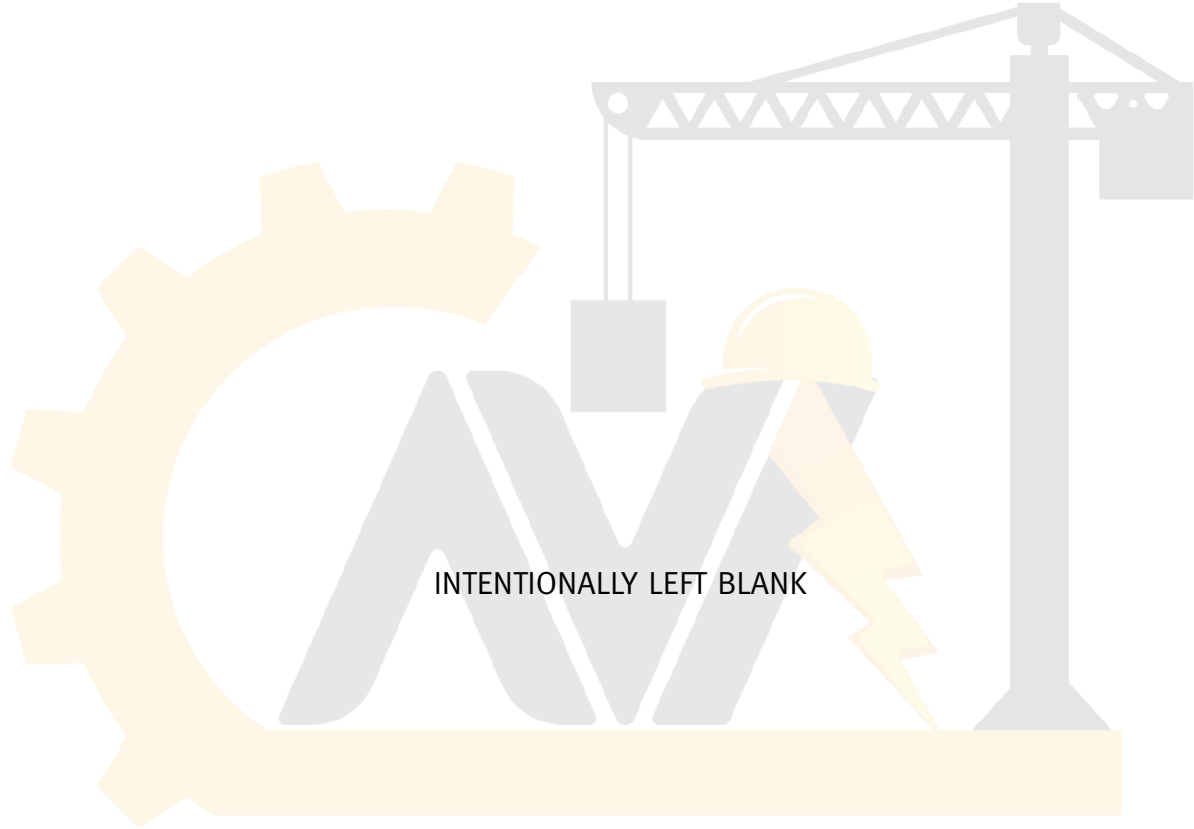

# آریا ایمن آوات



## ASME Services

ASME is committed to developing and delivering technical information. At ASME's Customer Care, we make every effort to answer your questions and expedite your orders. Our representatives are ready to assist you in the following areas:

ASME Press

*Codes & Standards*

Credit Card Orders

IMechE Publications

Meetings & Conferences

Member Dues Status

Member Services & Benefits

Other ASME Programs

Payment Inquiries

Professional Development

Short Courses

Publications

Public Information

Self-Study Courses

Shipping Information

Subscriptions/Journals/Magazines

Symposia Volumes

Technical Papers

### How can you reach us? It's easier than ever!

There are four options for making inquiries\* or placing orders. Simply mail, phone, fax, or E-mail us and a Customer Care representative will handle your request.

*Mail*

**ASME**

150 Clove Road, 6th Floor  
Little Falls, New Jersey  
07424-2138

*Call Toll Free*

**US & Canada:** 800-THE-ASME  
(800-843-2763)

**Mexico:** 95-800-THE-ASME  
(95-800-843-2763)

*Fax—24 hours*

973-882-1717  
973-882-5155

*E-Mail—24 hours*

customer care@asme.org

# آریا ایمن آوات

\* Customer Care staff are not permitted to answer inquiries about the technical content of this code or standard. Information as to whether or not technical inquiries are issued to this code or standard is shown on the copyright page. All technical inquiries must be submitted in writing to the staff secretary. Additional procedures for inquiries may be listed within.



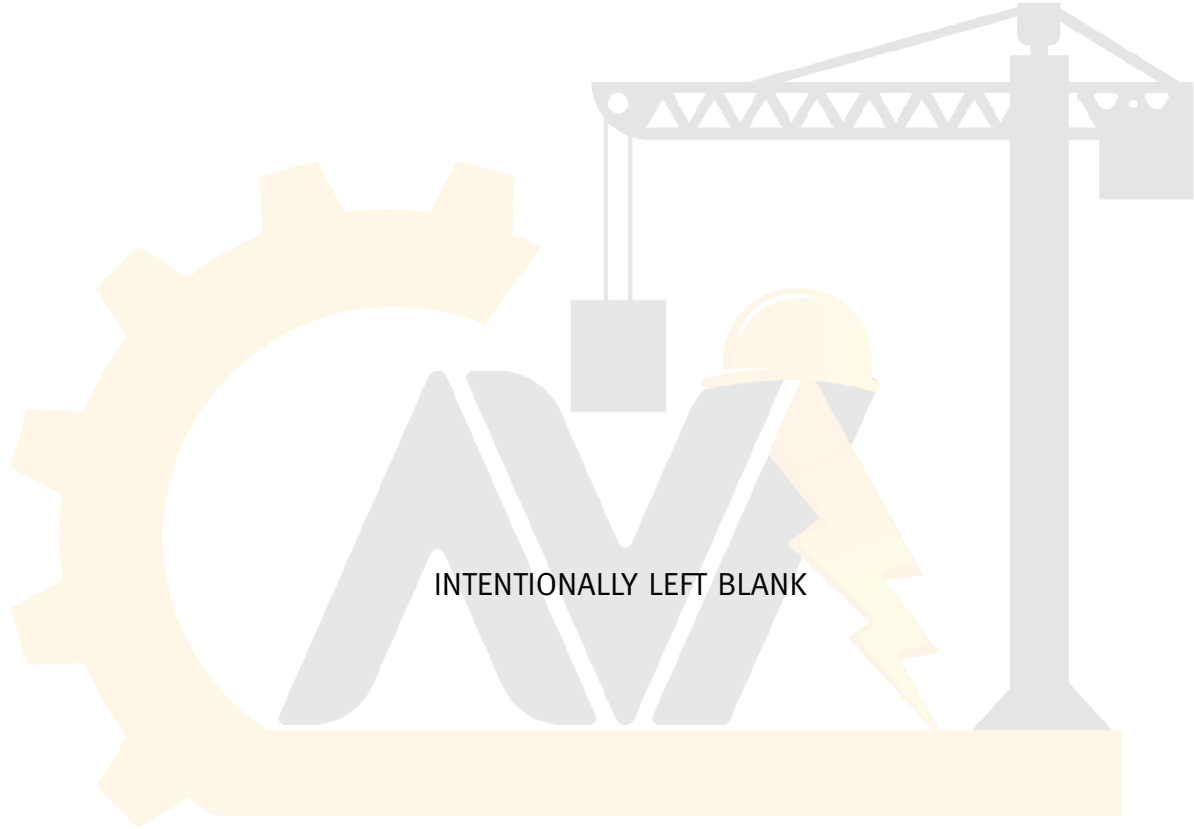

آریا ایمن آوات



30.18-2016

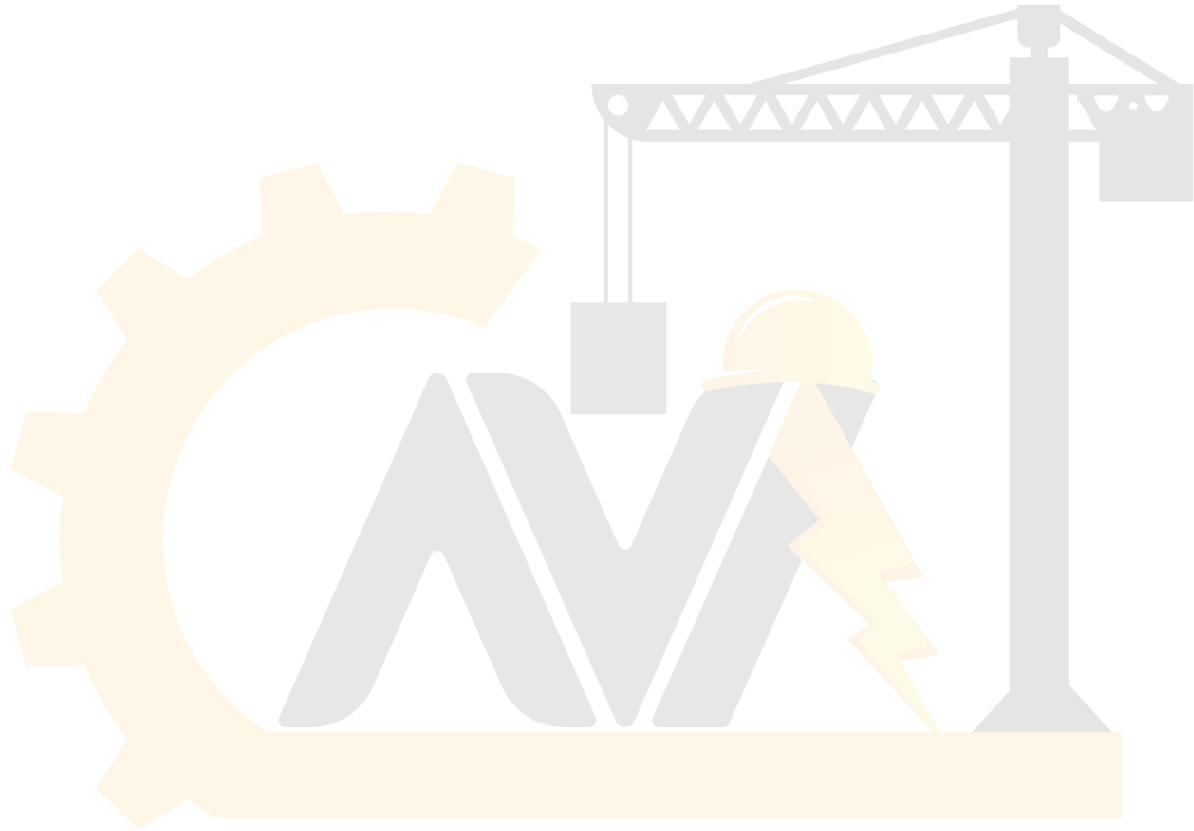

آریا ایمن آوات

ISBN 978-0-7918-7114-0



9 780791 871140



J 1 1 3 1 6