



ASME B30.20-2018
(Revision of ASME B30.20-2013)

Below-the-Hook Lifting Devices

**Safety Standard for Cableways,
Cranes, Derricks, Hoists, Hooks, Jacks,
and Slings**

AN AMERICAN NATIONAL STANDARD



**The American Society of
Mechanical Engineers**



ASME B30.20-2018
(Revision of ASME B30.20-2013)

Below-the-Hook Lifting Devices

**Safety Standard for Cableways,
Cranes, Derricks, Hoists, Hooks, Jacks,
and Slings**

AN AMERICAN NATIONAL STANDARD



**The American Society of
Mechanical Engineers**

Two Park Avenue • New York, NY • 10016 USA



Date of Issuance: July 25, 2018

The next edition of this Standard is scheduled for publication in 2023. This Standard will become effective 1 year after the Date of Issuance.

ASME issues written replies to inquiries concerning interpretations of technical aspects of this Standard. Interpretations are published on the ASME website under the Committee Pages at <http://cstools.asme.org/> as they are issued.

Errata to codes and standards may be posted on the ASME website under the Committee Pages to provide corrections to incorrectly published items, or to correct typographical or grammatical errors in codes and standards. Such errata shall be used on the date posted.

The Committee Pages can be found at <http://cstools.asme.org/>. There is an option available to automatically receive an e-mail notification when errata are posted to a particular code or standard. This option can be found on the appropriate Committee Page after selecting "Errata" in the "Publication Information" section.

ASME is the registered trademark of The American Society of Mechanical Engineers.

This code or standard was developed under procedures accredited as meeting the criteria for American National Standards. The Standards Committee that approved the code or standard was balanced to assure that individuals from competent and concerned interests have had an opportunity to participate. The proposed code or standard was made available for public review and comment that provides an opportunity for additional public input from industry, academia, regulatory agencies, and the public-at-large.

ASME does not "approve," "rate," or "endorse" any item, construction, proprietary device, or activity.

ASME does not take any position with respect to the validity of any patent rights asserted in connection with any items mentioned in this document, and does not undertake to insure anyone utilizing a standard against liability for infringement of any applicable letters patent, nor assume any such liability. Users of a code or standard are expressly advised that determination of the validity of any such patent rights, and the risk of infringement of such rights, is entirely their own responsibility.

Participation by federal agency representative(s) or person(s) affiliated with industry is not to be interpreted as government or industry endorsement of this code or standard.

ASME accepts responsibility for only those interpretations of this document issued in accordance with the established ASME procedures and policies, which precludes the issuance of interpretations by individuals.

No part of this document may be reproduced in any form,
in an electronic retrieval system or otherwise,
without the prior written permission of the publisher.

The American Society of Mechanical Engineers
Two Park Avenue, New York, NY 10016-5990

Copyright © 2018 by
THE AMERICAN SOCIETY OF MECHANICAL ENGINEERS
All rights reserved
Printed in U.S.A.



CONTENTS

| | |
|--|-----|
| Foreword | v |
| Committee Roster | vii |
| B30 Standard Introduction | ix |
| Summary of Changes | xii |
| Chapter 20-0 Scope, Definitions, Personnel Competence, Translations, and References | 1 |
| Section 20-0.1 Scope of ASME B30.20 | 1 |
| Section 20-0.2 Definitions — General | 1 |
| Section 20-0.3 Definitions for Chapter 20-1 | 1 |
| Section 20-0.4 Definitions for Chapter 20-2 | 2 |
| Section 20-0.5 Definitions for Chapter 20-3 | 2 |
| Section 20-0.6 Definitions for Chapter 20-4 | 3 |
| Section 20-0.7 Definitions for Chapter 20-5 | 3 |
| Section 20-0.8 Definitions for Chapter 20-6 | 3 |
| Section 20-0.9 Personnel Competence | 4 |
| Section 20-0.10 Translations | 4 |
| Section 20-0.11 References to Other Codes and Standards | 4 |
| Chapter 20-1 Structural and Mechanical Lifting Devices | 5 |
| Section 20-1.1 Scope | 5 |
| Section 20-1.2 Marking, Construction, and Installation | 5 |
| Section 20-1.3 Inspection, Testing, and Maintenance | 9 |
| Section 20-1.4 Operation | 11 |
| Section 20-1.5 Instruction Manuals | 13 |
| Chapter 20-2 Vacuum Lifting Devices | 14 |
| Section 20-2.1 Scope | 14 |
| Section 20-2.2 Marking, Construction, and Installation | 14 |
| Section 20-2.3 Inspection, Testing, and Maintenance | 16 |
| Section 20-2.4 Operation | 18 |
| Section 20-2.5 Instruction Manuals | 20 |
| Chapter 20-3 Close Proximity Operated Lifting Magnets | 21 |
| Section 20-3.1 Scope | 21 |
| Section 20-3.2 Marking, Construction, and Installation | 21 |
| Section 20-3.3 Inspection, Testing, and Maintenance | 23 |
| Section 20-3.4 Operation | 25 |
| Section 20-3.5 Instruction Manuals | 28 |
| Chapter 20-4 Remotely Operated Lifting Magnets | 29 |
| Section 20-4.1 Scope | 29 |
| Section 20-4.2 Marking, Construction, and Installation | 29 |
| Section 20-4.3 Inspection, Testing, and Maintenance | 30 |



| | | |
|---------------------|---|-----------|
| 20-5 | Operation | 33 |
| 20-5 | Instruction Manuals | 35 |
| 20-5 | Scrap and Material-Handling Grapples | 36 |
| Section 20-5.1 | Scope | 36 |
| Section 20-5.2 | Marking, Construction, and Installation | 36 |
| Section 20-5.3 | Inspection, Testing, and Maintenance | 36 |
| Section 20-5.4 | Operation | 39 |
| Section 20-5.5 | Instruction Manuals | 41 |
| Chapter 20-6 | Clamps | 42 |
| Section 20-6.1 | Scope | 42 |
| Section 20-6.2 | Marking, Construction, and Installation | 42 |
| Section 20-6.3 | Inspection, Testing, and Maintenance | 43 |
| Section 20-6.4 | Operation | 49 |
| Section 20-6.5 | Instruction Manuals | 51 |
| Figures | | |
| 20-1.1-1 | Structural Lifters | 6 |
| 20-1.1-2 | Mechanical Lifters | 7 |
| 20-1.1-3 | Mechanical Supporting Lifters | 8 |
| 20-2.1-1 | Vacuum Lifters | 15 |
| 20-3.1-1 | Close Proximity Operated Magnetic Lifters | 22 |
| 20-4.1-1 | Remotely Operated Magnetic Lifters | 29 |
| 20-5.1-1 | Scrap and Material-Handling Grapples | 37 |
| 20-6.0-1 | Load-Supporting Clamps | 43 |
| 20-6.0-2 | Friction-Type Pressure-Gripping Clamps | 44 |
| 20-6.0-3 | Indentation-Type Pressure-Gripping Clamps | 46 |
| 20-6.0-4 | Anchoring and Positioning Clamps | 47 |
| 20-6.0-5 | Hybrid Clamps | 47 |
| Table | | |
| 20-1.3.3-1 | Minimum Inspection for Below-the-Hook Lifting Devices | 10 |

آریا ایمن آوات



FOREWORD

This American National Standard, Safety Standard for Cableways, Cranes, Derricks, Hoists, Hooks, Jacks, and Slings, has been developed under the procedures accredited by the American National Standards Institute (ANSI). This Standard had its beginning in December 1916 when an eight-page Code of Safety Standards for Cranes, prepared by an ASME Committee on the Protection of Industrial Workers, was presented at the annual meeting of the ASME.

Meetings and discussions regarding safety on cranes, derricks, and hoists were held from 1920 to 1925, involving the ASME Safety Code Correlating Committee, the Association of Iron and Steel Electrical Engineers, the American Museum of Safety, the American Engineering Standards Committee (AESC) (later changed to American Standards Association (ASA), then to the United States of America Standards Institute (USASI), and finally to ANSI), Department of Labor — State of New Jersey, Department of Labor and Industry — State of Pennsylvania, and the Locomotive Crane Manufacturers Association. On June 11, 1925, AESC approved the ASME Safety Code Correlating Committee's recommendation and authorized the project with the U.S. Department of the Navy, Bureau of Yards and Docks, and ASME as sponsors.

In March 1926, invitations were issued to 50 organizations to appoint representatives to a Sectional Committee. The call for organization of this Sectional Committee was sent out October 2, 1926, and the committee organized November 4, 1926, with 57 members representing 29 national organizations. Commencing June 1, 1927, and using the eight-page code published by ASME in 1916 as a basis, the Sectional Committee developed the Safety Code for Cranes, Derricks, and Hoists. The early drafts of this safety code included requirements for Jacks, but, due to inputs and comments on those drafts, the Sectional Committee decided in 1938 to make the requirements for Jacks a separate code. In January 1943, ASA B30.2-1943 was published addressing a multitude of equipment types and in August 1943, ASA B30.1-1943 was published just addressing Jacks. Both documents were reaffirmed in 1952 and widely accepted as safety standards.

Due to changes in design, advancement in techniques, and general interest of labor and industry in safety, the Sectional Committee, under the joint sponsorship of ASME and the Bureau of Yards and Docks (now the Naval Facilities Engineering Command) was reorganized on January 31, 1962, with 39 members representing 27 national organizations. The new committee changed the format of ASA B30.2-1943 so that the multitude of equipment types it addressed could be published in separate volumes that could completely cover the construction, installation, inspection, testing, maintenance, and operation of each type of equipment that was included in the scope of ASA B30.2. This format change resulted in the initial publication of B30.3, B30.5, B30.6, B30.11 and B30.16 being designated as Revisions of B30.2 with the remainder of the B30 volumes being published as totally new volumes. ASA changed its name to USASI in 1966 and to ANSI in 1969, which resulted in B30 volumes from 1943 to 1968 being designated as either ASA B30, USAS B30, or ANSI B30, depending on their date of publication.

In 1982, the Committee was reorganized as an Accredited Organization Committee, operating under procedures developed by ASME and accredited by ANSI. This Standard presents a coordinated set of rules that may serve as a guide to government and other regulatory bodies and municipal authorities responsible for the guarding and inspection of the equipment falling within its scope. The suggestions leading to accident prevention are given both as mandatory and advisory provisions; compliance with both types may be required by employers of their employees.

In case of practical difficulties, new developments, or unnecessary hardship, the administrative or regulatory authority may grant variances from the literal requirements or permit the use of other devices or methods, but only when it is clearly evident that an equivalent degree of protection is thereby secured. To secure uniform application and interpretation of this Standard, administrative or regulatory authorities are urged to consult the B30 Committee, in accordance with the format described in [Section IX](#) of the Introduction, before rendering decisions on disputed points.

Safety codes and standards are intended to enhance public safety. Revisions result from committee consideration of factors such as technological advances, new data and changing environmental and industry needs. Revisions do not imply that previous editions were inadequate.

B30.20, Below-the-Hook Lifting Devices, was first published in 1985; new editions were published in 1993, 1999, 2003, and 2006. In the 2010 edition, maintenance was made mandatory, definitions were revised and other changes were made to improve clarity. The 2013 revision added requirements for personnel competence, operating controls marking and inspection, translation of non-English documentation into English, and updates to the definition of Duty Cycle to align with revisions made to BTH-1. In addition, responsibilities for Owners and Operators are defined for each piece of equipment. This 2018 edition adds Chapter 6 on Clamps, revisions to product safety labeling, addition of rated load marking requirements for remotely operated magnets, expanded and clarified magnet testing requirements, revision to the



agnet rating factor, revisions to align with recent changes to BTH-1, and updates to the operating practices align with revisions to the standards applicable to the equipment used with BTH lifters. Volume of the Standard, which was approved by the B30 Committee and by ASME, was approved by ANSI and designated as an American National Standard on April 24, 2018.

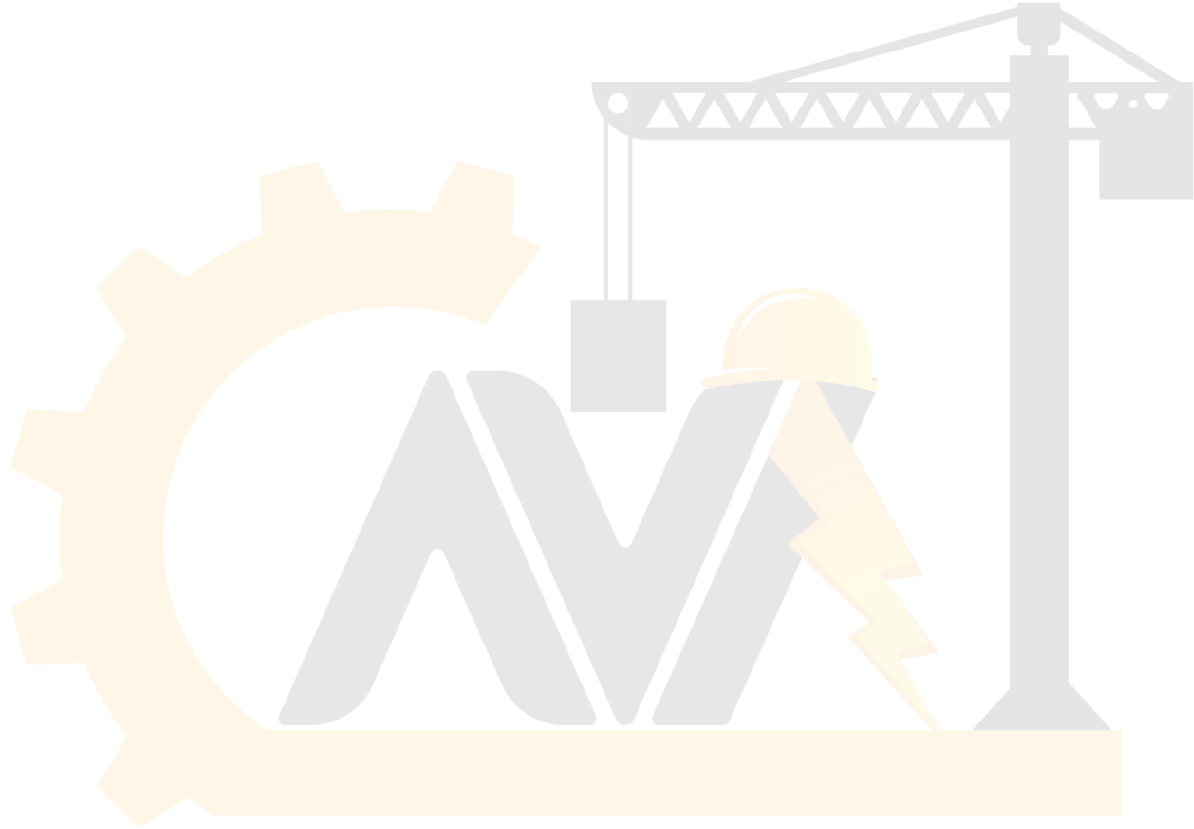

آریا ایمن آوات



ASME B30 COMMITTEE

Safety Standard for Cableways, Cranes, Derricks, Hoists, Hooks, Jacks, and Slings

(The following is the roster of the Committee at the time of approval of this Standard.)

STANDARDS COMMITTEE OFFICERS

B. D. Closson, *Chair*
T. L. Blanton, *Vice Chair*
K. M. Hyam, *Secretary*

STANDARDS COMMITTEE PERSONNEL

N. E. Andrew, LTS Cranes Mechanical
T. L. Blanton, NACB Group, Inc.
P. A. Boeckman, The Crosby Group, Inc.
P. W. Boyd, The Boeing Co.
B. D. Closson, Craft Forensic Services
J. A. Danielson, The Boeing Co.
D. R. Decker, Becket, LLC
L. D. Demark, Equipment Training Solutions, LLC
D. W. Eckstein, Eckstein & Associates, Inc.
R. J. Edwards, NBIS
A. J. Egging, National Oilwell Varco
E. D. Fidler, Grove U.S., LLC
J. A. Gilbert, Associated Wire Rope Fabricators
J. L. Gordon, Acco Material Handling Solutions, Inc.
N. C. Hargreaves, Consultant
G. B. Hetherston, Consultant
K. M. Hyam, The American Society of Mechanical Engineers
M. M. Jaxheimer, Navy Crane Center
P. R. Juhren, Morrow Equipment Co., LLC
R. M. Kohner, Landmark Engineering Services
A. J. Luci, Jr., LuMark Consulting, LLP
E. K. Marburg, Columbus McKinnon Corp.
L. D. Means, Means Engineering & Consulting
M. W. Mills, Liberty Mutual Insurance
D. L. Morgan, Critical Lift Consultants, LLC
W. E. Osborn, Ingersoll Rand
R. M. Parnell, Industrial Training International, Inc.
J. T. Perkins, First Solar Electric
B. A. Pickett, Systems Engineering and Forensic Services
J. A. Pilgrim, Manitowoc Cranes
S. K. Rammelsberg, CB&I
J. E. Richardson, U.S. Department of the Navy
D. W. Ritchie, Dave Ritchie Consultant, LLC
J. W. Rowland III, Consultant
J. C. Ryan, Boh Brothers Construction Co.
D. W. Smith, STI Group
W. J. Smith, Jr., NBIS
R. S. Stemp, Lampson International, LLC
R. G. Strain, Advanced Crane Technologies, LLC
J. Sturm, Sturm Corp.
P. D. Sweeney, Riverside Engineering, LLC
E. P. Vliet, Turner Industries Group, LLC
J. D. Wiethorn, Haag Engineering Co.
R. C. Wild, CJ Drilling, Inc.
D. N. Wolff, National Crane/Manitowoc Cranes
S. D. Wood, Terex Corp.
B. B. Bacon, *Alternate*, Tennessee Valley Authority
L. J. Bolen, *Alternate*, Consultant
G. J. Brent, *Alternate*, NCCCO
J. R. Burkey, *Alternate*, Columbus McKinnon Corp.
B. M. Casey, *Alternate*, General Dynamics Electric Boat
W. C. Dickinson, Jr., *Alternate*, Crane Industry Services, LLC
J. Dudley, *Alternate*, The Walsh Group
D. Duerr, *Alternate*, 2DM Associates, Inc.
M. Eggenberger, *Alternate*, Berry Contracting, Inc.
S. R. Fletcher, *Alternate*, Cowles, Murphy, Glover & Associates
M. Gardiner, *Alternate*, Haag Engineering Co.
D. M. Gordon, *Alternate*, Liberty Mutual Insurance
S. R. Gridley, *Alternate*, Navy Crane Center
D. A. Henninger, *Alternate*, Bridon America
D. F. Jordan, *Alternate*, American International Crane Bureau
K. Kennedy, *Alternate*, Navy Crane Center
J. Lindsay, *Alternate*, Link-Belt Construction Equipment
E. E. Lutter, *Alternate*, The Crosby Group, Inc.
T. C. Mackey, *Alternate*, WRPS Hanford
G. D. Miller, *Alternate*, Manitowoc Cranes
D. A. Moore, *Alternate*, Unified Engineering
L. S. Olver, *Alternate*, Kolo Holdings, Inc.
J. M. Randall, *Alternate*, CB&I
A. R. Ruud, *Alternate*, Atkinson Construction
J. R. Schober, *Alternate*, American Bridge Co.
J. Schoppert, *Alternate*, NBIS
L. Shapiro, *Alternate*, Howard I. Shapiro & Associates
K. J. Shinn, *Alternate*, K. J. Shinn, Inc.
C. H. Smith, *Alternate*, Morrow Equipment Co., LLC
S. Snider, *Alternate*, Ingersoll Rand
R. Stanoch, *Alternate*, IPS Cranes
C. Warren, *Alternate*, Webber, LLC
M. P. Zerba, *Alternate*, Lampson International, LLC



HONORARY MEMBERS

J. W. Downs, Jr., Downs Crane and Hoist Co.
J. J. Franks, Consultant
C. W. Ireland, Consultant

J. M. Klibert, Lift-All Co., Inc.
R. W. Parry, Consultant

B30.20 SUBCOMMITTEE PERSONNEL

P. W. Boyd, *Chair*, The Boeing Co.
B. Baker, Young Corp.
G. A. Bond, Wood's Powr-Grip Co., Inc.
D. Duerr, 2DM Associates, Inc.
J. D. Edmundson, Konecranes/P&H
T. Eicher, The Caldwell Group, Inc.
P. Friedrich, Industrial Magnetics, Inc.
F. G. Heath, Heath & Associates
K. M. Jankowski, Walker Magnetics Group
T. C. Mackey, WRPS Hanford
L. Radu, Mazzella Lifting Technologies

T. Raines, Jr., CMCO
D. T. Rebbin, Bradley Lifting
P. D. Sweeney, Riverside Engineering, LLC
D. Verenski, Hunter Lift, Ltd.
T. J. Brookbank, *Alternate*, Hunter Lift, Ltd.
T. Cobb, *Alternate*, Columbus McKinnon Forge Operations — Chattanooga
J. E. Rea, *Alternate*, Bradley Lifting Corp.
M. P. Zerba, *Alternate*, Lampson International, LLC
J. W. Downs, Jr., *Honorary Member*, Downs Crane and Hoist Co.

B30 INTEREST REVIEW GROUP

O. Akinboboye, Ropetech Engineering Services
D. Beltran, Gunnebo Johnson Corp.
J. D. Cannon, U.S. Army Corps of Engineers
B. Dobbs, LEEA
M. J. Eggenberger, Berry Contracting, Inc.
A. Gomes Rocha, Belgo Bekaert Arames
H. A. Hashem, Saudi Aramco
J. Hui, Si Pai Lou, School of Civil Engineering

C. Lan, Department of Industry — BSEE
A. C. Mattoli, Prowinch, LLC
J. P. Muhlbauer, All Ship & Cargo Surveys, Ltd.
L. S. Olver, Kolo Holdings, Inc.
G. L. Owens, Consultant
D. R. Remus, Reed Manufacturing
C.-C. Tsaur, Institute of Occupational Safety and Health

B30 REGULATORY AUTHORITY COUNCIL

C. Shelhamer, *Chair*, New York City Department of Buildings
K. M. Hyam, *Secretary*, The American Society of Mechanical Engineers
L. G. Champion, Department of Labor/OSHA
R. Feidt, Stephenson Equipment, Inc.
C. Harris, City of Chicago — Department of Buildings
R. D. Jackson, U.S. Department of Labor
J. L. Lankford, State of Nevada (OSHA)
D. E. Latham, Maryland Department of Labor, Licensing and Regulation
A. Lundeen, State of Washington, Department of Labor and Industries

J. Mendoza, North Carolina Department of Labor, Division of Occupational Safety
M. J. Nelmda, State of California, Occupational Safety and Health Standards Board
G. E. Pushies, Michigan OSHA
C. N. Stribling, Jr., Kentucky Labor Cabinet
T. Taylor, Minnesota Department of Labor & Industry
A. O. Omran, *Alternate*, New York City Department of Buildings
K. L. Powell, *Alternate*, Maryland Occupational Safety and Health — Division of Labor and Industry

B30 STANDARD INTRODUCTION

SECTION I: SCOPE

The ASME B30 Standard contains provisions that apply to the construction, installation, operation, inspection, testing, maintenance, and use of cranes and other lifting and material-movement-related equipment. For the convenience of the reader, the Standard has been divided into separate volumes. Each volume has been written under the direction of the ASME B30 Standards Committee and has successfully completed a consensus approval process under the general auspices of the American National Standards Institute (ANSI).

As of the date of issuance of this Volume, the B30 Standard comprises the following volumes:

- B30.1 Jacks, Industrial Rollers, Air Casters, and Hydraulic Gantries
- B30.2 Overhead and Gantry Cranes (Top Running Bridge, Single or Multiple Girder, Top Running Trolley Hoist)
- B30.3 Tower Cranes
- B30.4 Portal and Pedestal Cranes
- B30.5 Mobile and Locomotive Cranes
- B30.6 Derricks
- B30.7 Winches
- B30.8 Floating Cranes and Floating Derricks
- B30.9 Slings
- B30.10 Hooks
- B30.11 Monorails and Underhung Cranes (withdrawn 2018 — requirements found in latest revision of B30.17)
- B30.12 Handling Loads Suspended From Rotorcraft
- B30.13 Storage/Retrieval (S/R) Machines and Associated Equipment
- B30.14 Side Boom Tractors
- B30.15 Mobile Hydraulic Cranes (withdrawn 1982 — requirements found in latest revision of B30.5)
- B30.16 Overhead Underhung and Stationary Hoists
- B30.17 Cranes and Monorails (With Underhung Trolley or Bridge)
- B30.18 Stacker Cranes (Top or Under Running Bridge, Multiple Girder With Top or Under Running Trolley Hoist)
- B30.19 Cableways

- B30.20 Below-the-Hook Lifting Devices
- B30.21 Lever Hoists
- B30.22 Articulating Boom Cranes
- B30.23 Personnel Lifting Systems
- B30.24 Container Cranes
- B30.25 Scrap and Material Handlers
- B30.26 Rigging Hardware
- B30.27 Material Placement Systems
- B30.28 Balance Lifting Units
- B30.29 Self-Erecting Tower Cranes
- B30.30 Ropes¹
- B30.31 Self-Propelled, Towed, or Remote-Controlled Hydraulic Platform Transporters¹
- B30.32 Unmanned Aircraft Systems (UAS) Used in Inspection, Testing, Maintenance, and Lifting Operations¹

SECTION II: SCOPE EXCLUSIONS

Any exclusion of, or limitations applicable to, the equipment, requirements, recommendations, or operations contained in this Standard are established in the affected volume's scope.

SECTION III: PURPOSE

The B30 Standard is intended to

- (a) prevent or minimize injury to workers, and otherwise provide for the protection of life, limb, and property by prescribing safety requirements
- (b) provide direction to manufacturers, owners, employers, users, and others concerned with, or responsible for, its application
- (c) guide governments and other regulatory bodies in the development, promulgation, and enforcement of appropriate safety directives

SECTION IV: USE BY REGULATORY AGENCIES

These volumes may be adopted in whole or in part for governmental or regulatory use. If adopted for governmental use, the references to other national codes and standards in the specific volumes may be changed to refer to the corresponding regulations of the governmental authorities.

¹This volume is currently in the development process.



EFFECTIVE DATE

Effective Date. The effective date of this Volume of the B30 Standard shall be 1 yr after its date of issuance. Construction, installation, inspection, testing, maintenance, and operation of equipment manufactured and facilities constructed after the effective date of this Volume shall conform to the mandatory requirements of this Volume.

(b) *Existing Installations.* Equipment manufactured and facilities constructed prior to the effective date of this Volume of the B30 Standard shall be subject to the inspection, testing, maintenance, and operation requirements of this Standard after the effective date.

It is not the intent of this Volume of the B30 Standard to require retrofitting of existing equipment. However, when an item is being modified, its performance requirements shall be reviewed relative to the requirements within the current volume. The need to meet the current requirements shall be evaluated by a qualified person selected by the owner (user). Recommended changes shall be made by the owner (user) within 1 yr.

SECTION VI: REQUIREMENTS AND RECOMMENDATIONS

Requirements of this Standard are characterized by use of the word *shall*. Recommendations of this Standard are characterized by the word *should*.

SECTION VII: USE OF MEASUREMENT UNITS

This Standard contains SI (metric) units as well as U.S. Customary units. The values stated in U.S. Customary units are to be regarded as the standard. The SI units are a direct (soft) conversion from the U.S. Customary units.

SECTION VIII: REQUESTS FOR REVISION

The B30 Standards Committee will consider requests for revision of any of the volumes within the B30 Standard. Such requests should be directed to

Secretary, B30 Standards Committee
ASME Codes and Standards
Two Park Avenue
New York, NY 10016-5990

Requests should be in the following format:

- Volume: Cite the designation and title of the volume.
- Edition: Cite the applicable edition of the volume.
- Subject: Cite the applicable paragraph number(s) and the relevant heading(s).
- Request: Indicate the suggested revision.
- Rationale: State the rationale for the suggested revision.

Upon receipt by the Secretary, the request will be forwarded to the relevant B30 Subcommittee for consideration and action. Correspondence will be provided to the requester defining the actions undertaken by the B30 Standards Committee.

SECTION IX: REQUESTS FOR INTERPRETATION

The B30 Standards Committee will render an interpretation of the provisions of the B30 Standard. An Interpretation Submittal Form is available on ASME's website at <http://cstools.asme.org/Interpretation/InterpretationForm.cfm>.

Phrase the question as a request for an interpretation of a specific provision suitable for general understanding and use, not as a request for approval of a proprietary design or situation. Plans or drawings that explain the question may be submitted to clarify the question. However, they should not contain any proprietary names or information. Read carefully the note addressing the types of requests that the B30 Standards Committee can and cannot consider.

Upon submittal, the request will be forwarded to the relevant B30 Subcommittee for a draft response, which will then be subject to approval by the B30 Standards Committee prior to its formal issuance. The B30 Standards Committee may rewrite the question for the sake of clarity.

Interpretations to the B30 Standard will be available online at <https://cstools.asme.org/Interpretation/SearchInterpretation.cfm>.

SECTION X: ADDITIONAL GUIDANCE

The equipment covered by the B30 Standard is subject to hazards that cannot be abated by mechanical means, but only by the exercise of intelligence, care, and common sense. It is therefore essential to have personnel involved in the use and operation of equipment who are competent, careful, physically and mentally qualified, and trained in the proper operation of the equipment and the handling of loads. Serious hazards include, but are not limited to, improper or inadequate maintenance, overloading, dropping or slipping of the load, obstructing the free passage of the load, and using equipment for a purpose for which it was not intended or designed.

The B30 Standards Committee fully realizes the importance of proper design factors, minimum or maximum dimensions, and other limiting criteria of wire rope or chain and their fastenings, sheaves, sprockets, drums, and similar equipment covered by the Standard, all of which are closely connected with safety. Sizes, strengths, and similar criteria are dependent on many different factors, often varying with the installation and uses. These factors depend on

- (a) the condition of the equipment or material
- (b) the loads



- (d) acceleration or speed of the ropes, chains, sprockets, or drums
- (e) the type of attachments
- (e) the number, size, and arrangement of sheaves or other parts
- (f) environmental conditions causing corrosion or wear

(g) many variables that must be considered in each individual case

The requirements and recommendations provided in the volumes must be interpreted accordingly, and judgment used in determining their application.

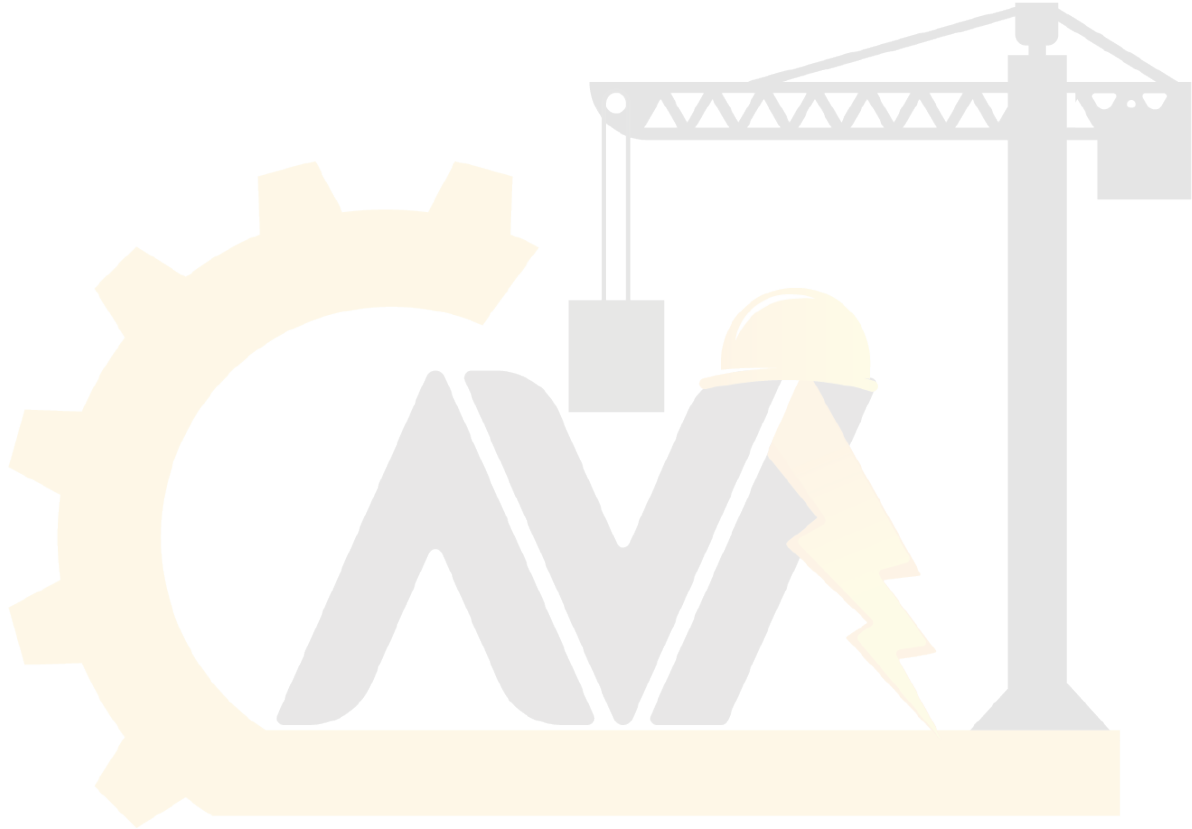

آریا ایمن آوات

ASME B30.20-2018 SUMMARY OF CHANGES

Following approval by the ASME B30 Committee and ASME, and after public review, ASME B30.20-2018 was approved by the American National Standards Institute on April 24, 2018.

ASME B30.20-2018 includes the following changes identified by a margin note, **(18)**.

| <i>Page</i> | <i>Location</i> | <i>Change</i> |
|-------------|---------------------------|---|
| ix | B30 Standard Introduction | Revised in its entirety |
| 1 | Section 20-0.1 | Second sentence and reference to new Chapter 20-6 added |
| 1 | Section 20-0.2 | (1) Definitions of <i>abnormal operating conditions</i> , <i>maintenance parts</i> , <i>severe service</i> , and <i>special or infrequent service</i> added (2) Definitions of <i>administrative or regulatory authority</i> , <i>alteration</i> , and <i>modified</i> deleted |
| 1 | Section 20-0.3 | (3) Definitions of <i>altered</i> , <i>below-the-hook lifting device</i> , <i>modification</i> , <i>rated load</i> , <i>shall</i> , and <i>should</i> revised (1) Definitions for <i>abnormal operating conditions</i> ; <i>friction-type pressure-gripping lifters</i> ; <i>grip ratio</i> ; <i>indentation-type pressure-gripping lifters</i> ; <i>ingot turnover</i> ; <i>lock bar sheet lifter</i> ; <i>service, severe</i> ; and <i>service, special or infrequent</i> deleted (2) Definitions for <i>heavy service</i> , <i>normal service</i> , and <i>supporting lifter</i> revised (3) Figures 20-0.3-1 through 20-0.3-5 deleted or moved to other Chapters |
| 2 | Section 20-0.4 | (1) Definitions for <i>abnormal operating conditions</i> ; <i>four-pad powered vacuum lifter</i> ; <i>four-pad powered vacuum lifter manipulator</i> ; <i>service, severe</i> ; and <i>service, special or infrequent</i> deleted (2) Definitions for <i>heavy service</i> , <i>normal service</i> , and <i>supporting lifter</i> revised (3) Figure 20-0.4-1 moved to Chapter 20-2 and redesignated as Figure 20-2.1-1 |
| 2 | Section 20-0.5 | Revised in its entirety |
| 3 | Section 20-0.6 | Revised in its entirety |
| 3 | Section 20-0.7 | (1) Definitions for <i>abnormal operating conditions</i> ; <i>scrap and material handling grapples</i> ; <i>service, severe</i> ; and <i>service, special</i> deleted |

| | | |
|----|------------------|---|
| | | (2) Definitions for <i>rated volume capacity</i> ; <i>service, heavy</i> ; and <i>service, normal</i> revised |
| | | (3) Figure 20-0.7-1 moved to Chapter 20-5 and redesignated as Figure 20-5.1-1 |
| 3 | Section 20-0.8 | Added, and remaining sections redesignated |
| 4 | Section 20-0.11 | Formerly Section 20-0.10; updated |
| 5 | Section 20-1.1 | Revised |
| 6 | Figure 20-1.1-1 | Added |
| 7 | Figure 20-1.1-2 | Added |
| 8 | Figure 20-1.1-3 | Added |
| 5 | 20-1.2.1 | Subparagraphs (b), (c), and (d)(1) revised |
| 5 | 20-1.2.2 | First paragraph and subparas. (a) and (c) revised |
| 9 | 20-1.3.1 | First paragraph and subparas. (a)(2), (b)(2)(-d), (b)(3)(-b), (b)(3)(-c), and (b)(3)(-d) revised |
| 10 | Table 20-1.3.3-1 | In "Item" column, fifth entry revised |
| 10 | 20-1.3.7 | Revised |
| 10 | 20-1.3.8.1 | Subparagraphs (a) and (b) revised |
| 11 | 20-1.3.8.2 | Subparagraphs (a) and (c) revised |
| 11 | 20-1.3.9 | (1) Subparagraph (b)(1)(-c) added (2) Subparagraph (b)(2) revised (3) Subparagraph (b)(6) deleted |
| 11 | 20-1.4.2 | Subparagraphs (a)(1) and (c) revised |
| 11 | 20-1.4.3.1 | Subparagraph (k) revised |
| 12 | 20-1.4.3.2 | Subparagraph (e) revised |
| 12 | 20-1.4.4 | (1) New subparagraph (b) added, and previous subpara. (b) redesignated as subpara. (c) (2) Subparagraphs (c) through (o) revised and redesignated as subparas. (d) through (p), respectively |
| 14 | Section 20-2.1 | Revised |
| 15 | Figure 20-2.1-1 | Moved from Chapter 20-0; previously designated as Figure 20-0.4-1 |
| 14 | 20-2.2.1 | Subparagraphs (b), (c), and (d)(1) revised |
| 14 | 20-2.2.2 | Revised in its entirety |
| 16 | 20-2.3.1 | First paragraph and subparas. (a)(1), (a)(2), (b)(2)(-d), (b)(3)(-b), (b)(3)(-c), and (b)(3)(-d) revised |
| 17 | 20-2.3.7 | First sentence revised |
| 17 | 20-2.3.8.1 | Subparagraphs (a) and (b) revised |
| 17 | 20-2.3.8.2 | Subparagraphs (a) and (b) revised |
| 18 | 20-2.3.9 | (1) Subparagraph (b)(2) revised (2) Subparagraphs (b)(1)(-c), (b)(2)(-c), and (b)(2)(-d) added (3) Subparagraph (b)(6) deleted |
| 18 | 20-2.4.2 | Subparagraphs (a)(1) and (c) revised |

| | | |
|----|-----------------|---|
| | 20-2.4.3.1 | Subparagraph (k) revised |
| | 20-2.4.3.2 | Subparagraph (e) revised |
| | 20-2.4.4 | (1) New subparagraph (b) added, and previous subpara. (b) redesignated as subpara. (c) (2) Subparagraphs (c) through (t) revised and redesignated as subparas. (d) through (u), respectively |
| 22 | Figure 20-3.1-1 | Added |
| 21 | 20-3.2.1 | Revised in its entirety |
| 22 | 20-3.2.2 | Revised in its entirety |
| 23 | 20-3.3.1 | First paragraph and subparas. (a)(1), (a)(2), (b)(2)(-d), (b)(3)(-b), (b)(3)(-c), and (b)(3)(-d) revised |
| 24 | 20-3.3.7 | First sentence revised |
| 24 | 20-3.3.8.1 | Subparagraphs (a) and (b) revised |
| 24 | 20-3.3.8.2 | Revised in its entirety |
| 25 | 20-3.3.9 | (1) Subparagraph (b)(1)(-c) added (2) Subparagraph (b)(2) revised (3) Subparagraph (b)(6) deleted |
| 25 | 20-3.4.2 | Subparagraphs (a)(1) and (c) revised |
| 26 | 20-3.4.3.1 | Subparagraph (k) revised |
| 26 | 20-3.4.3.2 | (1) Subparagraphs (e) and (i) revised (2) Subparagraph (r) added |
| 26 | 20-3.4.4 | Revised in its entirety |
| 28 | Section 20-3.5 | First paragraph and subparas. (a), (c), (d), and (e) revised |
| 29 | Figure 20-4.1-1 | Added |
| 29 | 20-4.2.1 | Revised in its entirety |
| 30 | 20-4.2.2 | Subparagraphs (a) through (e) revised |
| 30 | 20-4.3.1 | First paragraph and subparas. (a)(2), (b)(1)(-d), (b)(2)(-b), (b)(2)(-c), and (b)(2)(-d) revised |
| 31 | 20-4.3.2 | Subparagraph (f) added |
| 31 | 20-4.3.3 | Subparagraph (d) added |
| 31 | 20-4.3.6 | First sentence revised |
| 31 | 20-4.3.7 | Revised in its entirety |
| 32 | 20-4.3.8 | (1) Subparagraph (b)(1)(-c) added (2) Subparagraph (b)(2) revised (3) Subparagraph (b)(6) deleted |
| 33 | 20-4.4.2 | Subparagraphs (a), (a)(1), and (c) revised |
| 33 | 20-4.4.3.1 | Subparagraph (k) revised |
| 33 | 20-4.4.3.2 | (1) Subparagraph (i) revised (2) Subparagraphs (q) and (r) added |
| 34 | 20-4.4.4 | (1) New subparagraph (b) added, and previous subpara. (b) redesignated as subpara. (c) |

| | | |
|----|-----------------|--|
| 35 | Section 20-4.5 | (2) Previous subparas. (c) through (n) revised and redesignated as subparas. (d) through (o), respectively (3) Subparagraph (p) added First paragraph and subparas. (a), (c), (d), and (e) revised |
| 37 | Figure 20-5.1-1 | Moved from Chapter 20-0; previously designated as Figure 20-0.7-1 |
| 36 | 20-5.2.1 | Subparagraphs (a) and (b) revised in their entirety |
| 36 | 20-5.2.2 | Subparagraphs (a), (b), and (c) revised |
| 36 | 20-5.3.1 | First paragraph and subparas. (a)(2), (b)(1) (-d), (b)(2)(-b), (b)(2)(-c), and (b)(2)(-d) revised |
| 39 | 20-5.3.6 | First sentence revised |
| 39 | 20-5.3.7 | Subparagraphs (a) and (b) revised |
| 39 | 20-5.3.8 | (1) Subparagraphs (b)(1)(-b) and (b)(2) revised (2) Subparagraph (b)(6) deleted |
| 39 | 20-5.4.2 | Subparagraphs (a), (a)(4), and (c) revised |
| 40 | 20-5.4.4 | Subparagraphs (c), (d), (e), (g), and (j) revised |
| 42 | Chapter 20-6 | Added |



آریا ایمن آوات



Chapter 20-0

Scope, Definitions, Personnel Competence, Translations, and References

(18) SECTION 20-0.1: SCOPE OF ASME B30.20

Volume B30.20 includes provisions that apply to the marking, construction, installation, inspection, testing, maintenance, and operation of below-the-hook lifting devices, other than components addressed by other ASME B30 volumes or other standards, used for attaching loads to a hoist. The requirements in this Volume also apply to clamps used for positioning and anchoring. The devices are arranged in six chapters as follows:

| | |
|---------------|---|
| Chapter 20-1: | Structural and Mechanical Lifting Devices |
| Chapter 20-2: | Vacuum Lifting Devices |
| Chapter 20-3: | Close Proximity Operated Lifting Magnets |
| Chapter 20-4: | Remotely Operated Lifting Magnets |
| Chapter 20-5: | Scrap and Material-Handling Grapples |
| Chapter 20-6: | Clamps |

(18) SECTION 20-0.2: DEFINITIONS — GENERAL

abnormal operating conditions: environmental conditions that are unfavorable, harmful, or detrimental to or for the operation of the equipment, such as excessively high or low ambient temperatures, exposure to adverse weather, corrosive fumes, dust-laden or moisture-laden atmospheres, and hazardous locations.

altered: a physical change, addition, or deletion that modifies the original design, or intended functioning, of the equipment.

below-the-hook lifting device: a device used for attaching a load to a hoist. The device may contain components such as slings, hooks, and rigging hardware addressed by other ASME B30 volumes or other standards, typically referred to as a lifter.

design category: lifter classification that specifies the design factor to be used to establish static stress limits for the design.

hoist: a machinery unit that is used for lifting and lowering.

lifter: see *below-the-hook lifting device*.

lifting device: see *below-the-hook lifting device*.

maintenance parts: parts designated by the manufacturer that may be periodically replaced as part of normal operation of the lifter.

modification: see *altered*.

normal operating conditions: conditions during which the lifter is performing functions within the scope of the original design.

qualified person: a person who, by possession of a recognized degree in an applicable field or certificate of professional standing, or who, by extensive knowledge, training, and experience, has successfully demonstrated the ability to solve or resolve problems relating to the subject matter and work.

rated load: the maximum load designated by the manufacturer for which the equipment is designed and built.

repair: the process of reconditioning, renewal, or replacement of parts, components, and/or subsystems to a condition equal to the original manufacturer's specifications for the purpose of ensuring performance in accordance with the applicable requirements.

service class: lifter classification that establishes the allowable stress range for the specified fatigue life (load cycles).

severe service: service that involves normal or heavy service with abnormal operating conditions.

shall: a word indicating a requirement.

should: a word indicating a recommendation.

special or infrequent service: service that involves operation other than normal, heavy, or severe.

SECTION 20-0.3: DEFINITIONS FOR CHAPTER 20-1 (18)

heavy service: service that involves operation within the rated load limit that exceeds the limits of normal service.

latch: a device for holding a lifter in the open or closed position.

latch, automatic: a sequencing latch mechanism operated by lifter motion.

lifting beam (spreader beam): a load-supporting lifter [see Figure 20-1.1-1, illustration (a)].



lifter: a lifter that rotates the load about one during the lifting process (see [Figure 20-1.1-](#)

mechanical lifting device: a mechanism composed of two or more rigid parts which move with respect to each other for attaching a load to a hoisting device.

normal service:

Design Category A lifters (for ASME BTH-1): service that involves operation with various weights within the rated load limit with not more than four operations above 65% of the rated load limit per 24-hr period.

Design Category B lifters (for ASME BTH-1): service that involves operation with various weights within the rated load limit, averaging less than 65% of rated load limit.

structural lifting device: a lifter consisting of an assembly of rigid parts designed to hold and attach a load to a hoisting device.

supporting lifter: a lifter that carries the load on rigid projection(s) or bearing surface(s) [see [Figure 20-1.1-3](#), illustrations (b), (c), (d), and (e)].

(18) SECTION 20-0.4: DEFINITIONS FOR CHAPTER 20-2

heavy service: service that involves operation within the rated load limit that exceeds the limits of normal service.

horizontal surface lift: a condition where the surface to which the vacuum pad (or pads) is attached is in a horizontal plane.

nonporous material: a material that is not permeable by fluid/air.

normal service:

Design Category A lifters (for ASME BTH-1): service that involves operation with various weights within the rated load limit with not more than four operations above 65% of the rated load limit per 24-hr period.

Design Category B lifters (for ASME BTH-1): service that involves operation with various weights within the rated load limit, averaging less than 65% of rated load limit.

porous material: a material that is permeable by fluid/air.

seal ring (seal): that part of the vacuum pad which forms the seal of the vacuum chamber between the vacuum pad body or vacuum lifting device and the attached material.

single-pad mechanical vacuum lifter: see [Figure 20-2.1-1](#), illustration (b).

two-pad mechanical vacuum lifter: see [Figure 20-2.1-1](#), illustration (a).

vacuum: pressure less than ambient atmospheric pressure.

vacuum lifter: a below-the-hook lifting device for lifting and transporting loads using a holding force by means of vacuum (see [Figure 20-2.1-1](#)).

vacuum manipulator: a vacuum lifter capable of repositioning the load while suspended.

vacuum pad: a device that applies a holding force on the load by means of vacuum.

vacuum reservoir: the evacuated portion of the vacuum system that functions to compensate for leakage into the vacuum system or to provide a vacuum reserve in the event of vacuum generator failure.

vertical surface lift: a condition where the surface to which a vacuum pad is attached is in a vertical plane.

SECTION 20-0.5: DEFINITIONS FOR CHAPTER 20-3

(18)

battery backup system: batteries used to guard against inadvertent load release due to the loss of primary power to the system.

battery-powered lifting electromagnet: a lifting magnet that requires continuous current supplied by a battery to maintain holding force [see [Figure 20-3.1-1](#), illustration (a)].

breakaway force: the force required to detach a properly engaged lifting magnet from a piece of ferromagnetic material when the force is applied normal to the lifting surface of the magnet.

breakaway force test: a test that is carried out per [para. 20-3.3.8.2](#) in order to establish the rated breakaway force.

close proximity operated lifting magnet: a lifting magnet used in such a fashion that the operator manually positions the lifting magnet on the load, and manually guides the lifting magnet and load during a lift.

cold current: the current drawn by the lifting magnet when its coil is at 68°F (20°C) and at rated voltage.

electrically controlled permanent lifting magnet: a lifting magnet that derives holding force from permanent magnet material and requires electrical current during attachment or release. Also known as Electro Perm, Perm Electro, or similar names [see [Figure 20-3.1-1](#), illustration (b)].

externally powered lifting electromagnet: a lifting magnet suspended from a crane that requires power from an external source.

general application lifting magnet: lifting magnets that are intended by the manufacturer to be used on a number of different geometrical shapes and do not fall under the category of remotely operated lifting magnets.

heavy service: service that involves operation within the rated load limit that exceeds the limits of normal service.

internal control function indicator: an indicator which shows that the permanent magnet material in one type of electrically controlled permanent magnet has been positioned internally to provide full magnetic attraction.



uty cycle: the percentage of time an electro-magnet can be energized (T_e), relative to total cycle time. Deenergized time equals T_d . If not rated as continuous, the magnet duty cycle rating includes information on maximum continuous energized time and minimum deenergized time to prevent overheating.

$$\text{magnet duty cycle} = \frac{T_e}{T_e + T_d} \times 100$$

EXAMPLE: 3 min energized, 2 min deenergized equal

$$\frac{3}{3 + 2} \times 100 = 60\%$$

manually controlled permanent lifting magnet: a lifting magnet that derives holding force from permanent magnet material and requires a manual effort during period of attachment or release [see Figure 20-3.1-1, illustration (c)].

normal service: service that involves operation with various weights within the rated load limit, averaging less than 65% of rated load with the magnet operating at, or below, the rated duty cycle.

rated load: the maximum load that the lifting magnet is designated by the manufacturer to handle.

remotely operated lifting magnet: a lifting magnet that does not require the operator or other personnel to be in close proximity to the lifting magnet or its load while the lifting magnet is in use.

specified application breakaway force test: a test that is carried out in accordance with instructions from the manufacturer of the lifting magnet in order to establish the application breakaway force.

specified application lifting magnet: lifting magnets that are designed for lifting specified geometrical configurations and weights of designated parts, identified by part number or other controlled definition and used in a controlled manner.

specified application load: a load applied to the lifting magnet when it is used to handle a specified load.

(18) **SECTION 20-0.6: DEFINITIONS FOR CHAPTER 20-4**

close proximity operated lifting magnet: a lifting magnet used in such a fashion that the operator manually positions the lifting magnet on the load, and manually guides the lifting magnet and load during a lift.

cold current: the current drawn by the lifting magnet when its coil is at 68°F (20°C) and at rated voltage.

heavy service: service that involves operation within the rated load limit that exceeds the limits of normal service.

magnet duty cycle: the percentage of time an electro-magnet can be energized (T_e), relative to total cycle time. Deenergized time equals T_d . If not rated as continuous, the magnet duty cycle rating includes information on maximum continuous energized time and minimum deenergized time to prevent overheating.

$$\text{magnet duty cycle} = \frac{T_e}{T_e + T_d} \times 100$$

EXAMPLE: 3 min energized, 2 min deenergized equal

$$\frac{3}{3 + 2} \times 100 = 60\%$$

normal service: service that involves operation with various weights within the rated load limit, averaging less than 65% of rated load with the magnet operating at, or below, the rated duty cycle over one shift (8 hr).

rated load: the maximum load that the lifting magnet is designated by the manufacturer to handle.

remotely operated lifting magnet: a lifting magnet that does not require the operator or other personnel to be in close proximity to the lifting magnet or its load while the lifting magnet is in use [see Figure 20-4.1-1, illustrations (a) and (b)].

SECTION 20-0.7: DEFINITIONS FOR CHAPTER 20-5 (18)

heavy service: service that involves operation within the rated capacity and load limit for:

(a) one work shift per day working in material that will not crush or deform as the grapple closes

(b) two or more work shifts per day working in material that will crush or deform as the grapple closes

normal service: service that is limited to operation for a period of one shift or less per day working within the rated load limit in material that will crush or deform as the grapple closes.

rated volume capacity: the volume of scrap/material that can be handled with the grapple closed and the tine tips touching. This is to be expressed in cubic yards or cubic meters.

tine: the hinged portion of the grapple that comes in contact with or encompasses the load.

SECTION 20-0.8: DEFINITIONS FOR CHAPTER 20-6 (18)

friction-type pressure-gripping clamps: clamps that grip the load without significant or harmful permanent deformation of the load surface (see Figure 20-6.0-2).

heavy service: service that involves operation within the rated load limit that exceeds the limits of normal service.



type pressure-gripping clamps: clamps that are used by applying force to indent the sides of the clamps (see Figure 20-6.0-3).

normal service:

Design Category A lifters (for ASME BTH-1): service that involves operation with various weights within the rated load limit with not more than four operations above 65% of the rated load limit per 24-hr period.

Design Category B lifters (for ASME BTH-1): service that involves operation with various weights within the rated load limit, averaging less than 65% of rated load limit.

SECTION 20-0.9: PERSONNEL COMPETENCE

Persons performing the functions identified in this Volume shall, through education, training, experience, skill, and physical fitness, as necessary, be competent and capable to perform the functions as determined by the employer or employer's representative.

SECTION 20-0.10: TRANSLATIONS

20-0.10.1 Technical and Safety-Related Information

The manufacturer shall provide instructions [manual (s)] for the operation, inspection, testing, maintenance, assembly, and disassembly of the equipment.

(a) The instructions shall be provided in a language specified by the purchaser at the time of the initial sale by the manufacturer.

(b) Pictograms used to identify controls shall be described in the instructions. The pictograms should comply with ISO 7000, ISO 7296, or other recognized source, if previously defined.

(c) Translations of the original language instructions (if the manufacturer no longer exists, translation of the instructions with the equipment is acceptable) shall meet professional translation industry standards, which include, but are not limited to, the following:

- (1) translating the complete paragraph message, instead of word by word
- (2) ensuring grammatical accuracy
- (3) preserving the source document content without omitting or expanding the text
- (4) translating the terminology accurately
- (5) reflecting the level of sophistication of the original document

(d) The finished translation shall be verified for compliance with (c)(1) through (c)(5) by a qualified person having an understanding of the technical content of the subject matter.

20-0.10.2 Translation of Technical and Safety-Related Information and Manual(s)

The entities responsible for the operation, use, inspection, testing, and maintenance of the covered equipment shall have the technical and safety-related information available in a language that their employees can read and understand. The entities shall obtain a translation of the original manufacturer's written safety information and manuals from the manufacturer or from a translation service provider if the manuals are not in a language understood by their employees. The translation(s) shall meet the requirements of paras. 20-1.10-1(c) and 20-1.10-1(d).

SECTION 20-0.11: REFERENCES TO OTHER CODES AND STANDARDS (18)

The following is a list of publications referenced in this Volume:

ANSI Z535.4-2011, Product Safety Signs and Labels
Publisher: American National Standards Institute (ANSI),
25 West 43rd Street, New York, NY 10036
(www.ansi.org)

ASME B30.9-2014, Slings
ASME B30.10-2014, Hooks
ASME B30.26-2015, Rigging Hardware
ASME BTH-1-2017, Design of Below-the-Hook Lifting Devices
Publisher: The American Society of Mechanical Engineers (ASME), Two Park Avenue, New York, NY 10016-5990
(www.asme.org)

ISO 7000-2012, Graphical symbols for use on equipment — Registered symbols
ISO 7296-1991, Cranes — Graphical symbols — Parts 1-3
Publisher: International Organization for Standardization (ISO), Central Secretariat, Chemin de Blandonnet 8, Case Postale 401, 1214 Vernier, Geneva, Switzerland
(www.iso.org)

NFPA 70, National Electrical Code
Publisher: National Fire Protection Association (NFPA), 1 Batterymarch Park, Quincy, MA 02169-7471
(www.nfpa.org)



Chapter 20-1 Structural and Mechanical Lifting Devices

(18) SECTION 20-1.1: SCOPE

Chapter 20-1 applies to the classification, marking, construction, installation, inspection, testing, maintenance, and operation of structural and mechanical lifting devices. Structural and mechanical lifters/lifting devices are categorized as load-supporting lifters, and include a positive connection to the load or other component (see Figures 20-1.1-1, 20-1.1-2, and 20-1.1-3). Structural and mechanical lifting devices frequently contain components within the scope of Chapters 20-2 through 20-6 for load attachment.

SECTION 20-1.2: MARKING, CONSTRUCTION, AND INSTALLATION

(18) 20-1.2.1 Marking

(a) *Rated Load.* The rated load of the lifting device shall be legibly marked on its main structure or on a tag attached to its main structure where it is visible. If the lifting device is made up of several lifters, each detachable from the group, these lifters shall also be marked with their individual rated loads.

(b) *Identification.* Structural and mechanical lifting devices shall be marked with, but not limited to, the following information:

- (1) manufacturer's name and contact information
- (2) serial number (unique unit identifier)
- (3) lifter weight, if over 100 lb (45 kg)
- (4) cold current (amps) (when applicable)
- (5) rated voltage (when applicable)
- (6) rated load [as described in (a)]
- (7) ASME BTH-1 Design Category
- (8) ASME BTH-1 Service Class

(c) *Repaired or Altered Lifters.* Repaired or altered structural and mechanical lifters shall be provided with identification displaying, but not limited to, the following information:

- (1) name and contact information of the repairer or alterer
- (2) repairer's or alterer's unit identification
- (3) lifter weight (if altered)
- (4) cold current (amps) (if altered)
- (5) rated voltage (if altered)
- (6) rated load (if altered) [as described in (a)]
- (7) ASME BTH-1 Design Category (if altered)

(8) ASME BTH-1 Service Class (if altered)

This requirement is not applicable to repairs limited to replacement of maintenance parts.

(d) *Product Safety Labels*

(1) Where size and shape of the lifter allow, lifters shall have labels affixed to them in a readable position, that include the appropriate signal word, according to ANSI Z535.4-2011, to bring the label to the attention of the operator. The label should include cautionary language identifying hazards, methods for accident prevention, and refer to instruction manuals for additional information.

(2) Where size or shape of the lifter prohibits the inclusion of all or any such markings, a label shall be affixed, referring user to consult manufacturer's instruction manual for product safety information.

(e) *Operating Controls.* Each control shall be clearly marked describing resulting motion or function of the lifter.

20-1.2.2 Construction

(18)

The manufacturer shall verify that structural and mechanical lifting devices are designed in accordance with ASME BTH-1.

Structural and mechanical lifting devices shall be designed to ASME BTH-1 Design Category B (static strength criteria) and the proper Service Class (fatigue life criteria) selected for its number of load cycles, unless a qualified person representing the owner, purchaser, or user of the lifting device determines and can demonstrate that ASME BTH-1 Design Category A is appropriate.

Design Category A shall only be designated when the magnitude and variation of loads applied to the lifter are predictable and do not exceed the rated capacity, where the loading and environmental conditions are accurately defined, service is not severe, and the anticipated number of load cycles does not exceed Service Class 0.

(a) *Welding.* Welding shall be in accordance with ASME BTH-1, para. 1-4.6.

(b) *Guards for Moving Parts.* Exposed moving parts, such as, but not limited to, gearing, projecting shafts, and chain drives, that constitute a hazard under normal operating conditions, should be guarded.

Figure 20-1.1-1 Structural Lifters

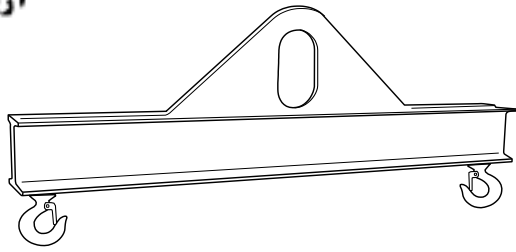

(a) Spreader Beam

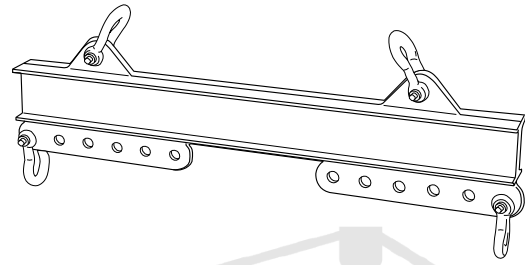

(b) Adjustable Spreader Bar

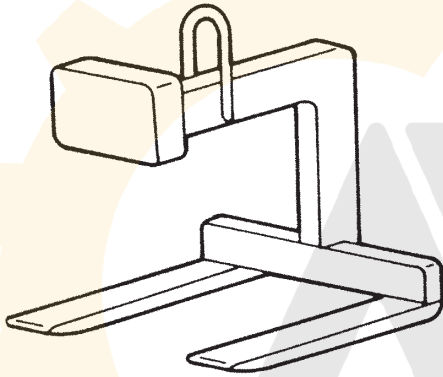

(c) Balanced Pallet Lifter

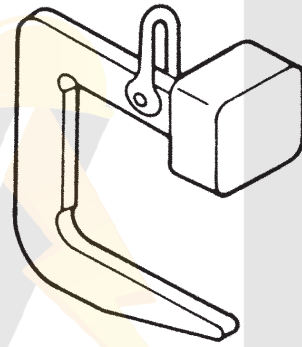

(d) Balanced "C" Lifter

آریا ایمن آوات

Figure 20-1.1-2 Mechanical Lifters

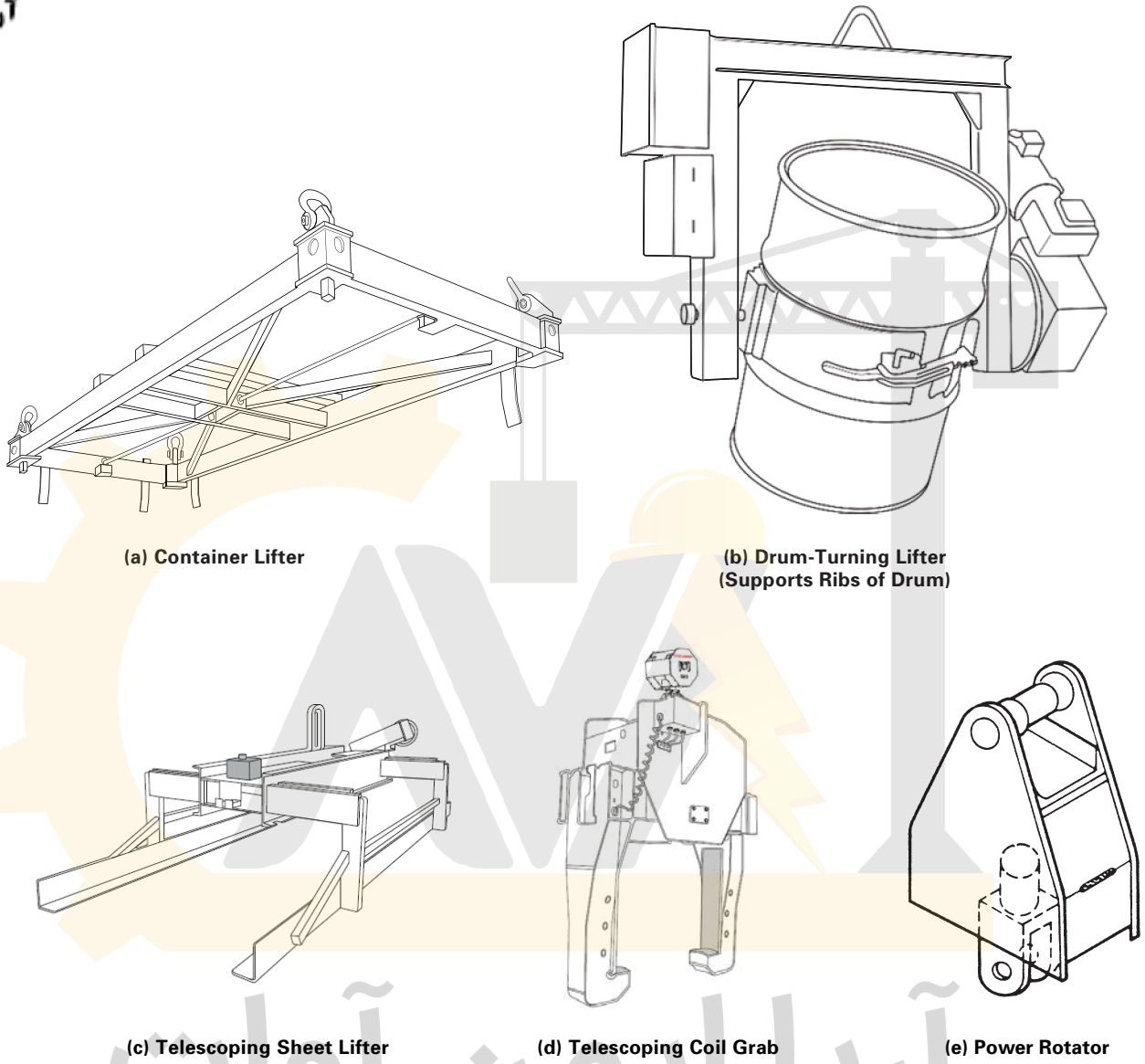

آریا امین آوات

Figure 20-1.1-3 Mechanical Supporting Lifters

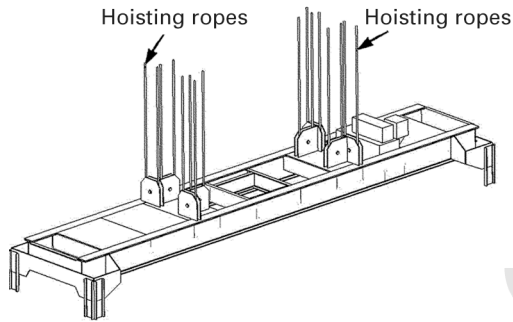

(a) Lifting Beam
(Reeved Into Hoist Ropes)

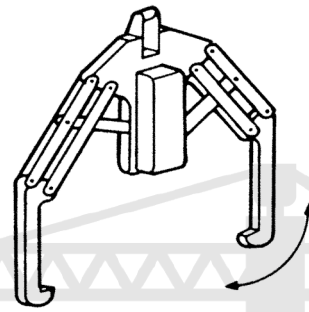

(b) Parallel Coil Grab

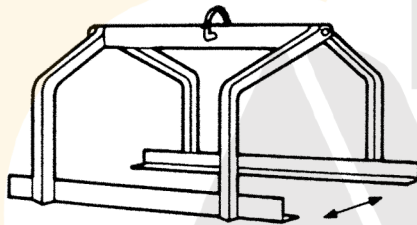

(c) Simple Sheet Lifter

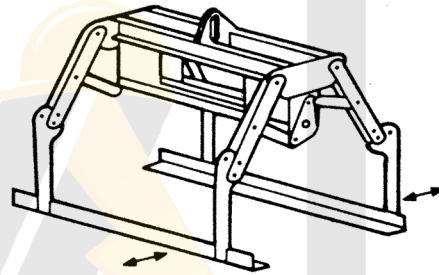

(d) Lock Bar Sheet Lifter

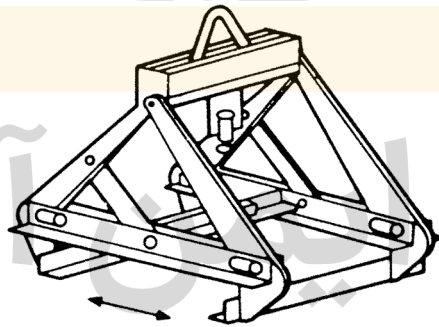

(e) Rack Lifter



Electrical Equipment. External power supply, electrical equipment, and wiring for below-the-hook lifters shall be in accordance with ASME BTH-1.

(d) *Alterations.* Structural and mechanical lifters may be altered or rerated, provided such alterations are analyzed and approved by the equipment manufacturer or a qualified person. A rerated lifter, or one whose components have been altered, shall conform to [para. 20-1.2.2](#) and be tested according to [para. 20-1.3.8](#). New rated load shall be displayed in accordance with [para. 20-1.2.1](#).

(e) *Slings.* When employed, slings shall meet the requirements of ASME B30.9.

(f) *Hooks.* When employed, hooks shall meet the requirements of ASME B30.10.

(g) *Rigging Hardware.* When employed, rigging hardware shall meet the requirements of ASME B30.26.

20-1.2.3 Installation

(a) The lifter shall be installed in accordance with the manufacturer's instructions.

(b) The installer shall check for correct rotation of all motors.

SECTION 20-1.3: INSPECTION, TESTING, AND MAINTENANCE

(18) 20-1.3.1 Inspection Classification

General. All inspections shall be performed by a designated person. Any deficiencies identified shall be examined and a determination made by a qualified person as to whether they constitute a hazard, and if so, what additional steps need to be taken to address the hazard.

Inspection of slings (ASME B30.9), hooks (ASME B30.10), rigging hardware (ASME B30.26), or other special devices shall comply with the inspection requirements in the applicable volume.

(a) Initial Inspection

(1) New and reinstalled lifters shall be inspected prior to initial use to verify compliance with applicable provisions of this Volume.

(2) Altered or repaired lifters shall be inspected. The inspection may be limited to the components affected by the alteration or repair, as determined by a qualified person.

(b) *Inspection Intervals.* Inspection procedure for lifters in regular service is divided into three general classifications based upon the intervals at which inspection should be performed. The intervals, in turn, are dependent upon the critical components of the lifters and the degree of their exposure to wear, deterioration, or malfunction. The three general classifications are herein designated as *every lift*, *frequent*, and *periodic*, with respective intervals between inspections as defined below.

(1) *Every Lift Inspection.* Visual examination by the operator before and during each lift made by the lifter.

(2) *Frequent Inspection.* Visual examinations by the operator or other designated persons with records not required.

(-a) Normal service — monthly

(-b) Heavy service — weekly to monthly

(-c) Severe service — daily to weekly

(-d) Special or infrequent service — as recommended by a qualified person before and after each lift

(3) *Periodic Inspection.* Visual inspection making records of apparent external conditions to provide the basis for a continuing evaluation. An external code mark on the lifter is an acceptable identification in lieu of records.

(-a) Normal service for equipment in place — yearly

(-b) Heavy service — semiannually

(-c) Severe service — quarterly

(-d) Special or infrequent service — as recommended by a qualified person before the first such lift and as directed by the qualified person for any subsequent lifts

20-1.3.2 Every Lift Inspection

Items such as the following shall be inspected by the operator before and/or during every lift for any indication of damage as specifically indicated, including observations during operation for any damage that might occur during the lift:

(a) surface of the load for debris

(b) condition and operation of the controls

(c) condition and operation of the indicators and meters when installed

20-1.3.3 Frequent Inspection (See Also Table 20-1.3.3-1)

Items such as the following shall be inspected for damage at intervals as defined in [para. 20-1.3.1\(b\)\(2\)](#), including observations during operation for any indications of damage that might appear between inspections. A qualified person shall determine whether any indications of damage constitute a hazard or will require more frequent inspection. For all lifters, inspect

(a) structural members for deformation, cracks, or excessive wear on any part of the lifter

(b) loose or missing guards, fasteners, covers, stops, or nameplates

(c) all functional operating mechanisms and automatic hold-and-release mechanisms for misadjustments interfering with operation

(d) missing or illegible operating control markings



Table 20-1.3.3-1 Minimum Inspection for Below-the-Hook Lifting Devices

| Item | Normal Service | | Heavy Service | | Severe Service | |
|---|----------------------------|--------------------------|--------------------------------------|--------------------------------|------------------------------------|-----------------------------|
| | Visual, Monthly [Note (1)] | Record Yearly [Note (2)] | Visual, Weekly to Monthly [Note (1)] | Record Semiannually [Note (3)] | Visual, Daily to Weekly [Note (3)] | Record Quarterly [Note (3)] |
| Frequent Inspection (refer to para. 20-1.3.3) — structural deformation, cracks, or excessive wear of any part of the lifter | X | ... | X | ... | X | ... |
| Loose or missing guards, fasteners, covers, stops, or nameplates | X | ... | X | ... | X | ... |
| All functional operating mechanisms and automatic hold and release mechanisms for misadjustments interfering with operation | X | ... | X | ... | X | ... |
| Periodic Inspection (refer to para. 20-1.3.4) — loose bolts or fasteners | ... | X | ... | X | ... | X |
| Cracked or worn gears, pulleys, sheaves, sprockets, bearings, drive chains, and belts | ... | X | ... | X | ... | X |
| Excessive wear of linkages and other mechanical parts | ... | X | ... | X | ... | X |
| Excessive wear at hoist hooking points and load support clevises, or pins | ... | X | ... | X | ... | X |

NOTES:

- (1) By operator or designated person with records not required.
- (2) Visual inspection by designated person making records of apparent external conditions to provide the basis for a continuing evaluation.
- (3) As in Note (2), unless external conditions indicate that disassembly should be done to permit detailed inspection.

20-1.3.4 Periodic Inspection (See Also Table 20-1.3.3-1)

Complete inspection of the lifter shall be performed at intervals as defined in para. 20-1.3.1(b)(3). Any deficiencies, such as listed below, shall be examined and determination made as to whether they constitute a hazard. These inspections shall include the requirements of para. 20-1.3.3 and, in addition, items such as the following:

- (a) loose bolts or fasteners
- (b) cracked or worn gears, pulleys, sheaves, sprockets, bearings, drive chains, and belts
- (c) excessive wear of friction pads, linkages, and other mechanical parts
- (d) excessive wear at hoist hooking points and load support clevises or pins
- (e) missing or illegible product safety labels required by para. 20-1.2.1(d)

20-1.3.5 Lifting Devices Not in Regular Use

A lifter that has been idle for a period of 1 month to 1 yr shall be inspected in accordance with para. 20-1.3.3 before being placed in service. A lifter that has been idle for a period of 1 yr or more shall be inspected in accordance with para. 20-1.3.4 before being returned to service.

20-1.3.6 Inspection Records

Dated inspection reports shall be made on critical items such as those listed in para. 20-1.3.4. Records should be available for each periodic inspection and when the lifter is either altered or repaired.

20-1.3.7 Repairs

(18)

Damage disclosed by the inspection requirements of Section 20-1.3 shall be corrected according to the procedures outlined in para. 20-1.3.9 before operation of the lifter is resumed, unless a qualified person determines the damage does not constitute a hazard. Repairs of slings (ASME B30.9), hooks (ASME B30.10), rigging hardware (ASME B30.26), or other special devices shall comply with repair requirements in the applicable volumes or standards.

20-1.3.8 Testing

20-1.3.8.1 Operational Tests

(18)

(a) New and reinstalled lifting devices shall be tested by a qualified person, or a designated person under the direction of the manufacturer or a qualified person, prior to initial use to verify compliance with applicable provisions of this Volume, including, but not limited to, the following:

(1) *Moving Parts.* Lifters with moving parts shall be tested to determine that the lifter operates in accordance with manufacturer’s instructions.

(2) *Latches.* Lifters with manually operated or automatic latches shall be tested to determine that the latch operates in accordance with manufacturer’s instructions.

(b) Altered or repaired lifters shall be tested by a qualified person, or a designated person under the direction of the manufacturer or a qualified person. This test may be limited to the components affected by the alteration or



determined by a qualified person with guidance from the manufacturer.

All indicator lights, gages, horns, bells, alarms, pointers, and other warning devices shall be tested.

(d) Dated reports of all operational tests shall be filed.

(18) **20-1.3.8.2 Load Test**

(a) Prior to initial use, all new, altered, or repaired lifting devices should be tested and inspected. If performed, tests shall be done under the direction of the manufacturer or a qualified person and a written report be furnished by such a person, confirming the load rating of the lifter. The load rating should not be more than 80% of the maximum load sustained during the test. Test loads shall not be more than 125% of the rated load unless otherwise recommended by the manufacturer. Test reports should be available.

(b) The load test, if made, shall consist of the following operations as a minimum requirement:

(1) Hoist the test load a sufficient distance to ensure the load is supported by the lifter, or apply the required load if the test is made using a testing machine.

(2) After the test load is released, visually inspect the lifter for deformation, cracks, or other defects.

(c) Tests of altered or repaired lifters may be limited to the components affected by the alteration or repair, as determined by a qualified person with guidance from the manufacturer.

(18) **20-1.3.9 Maintenance**

(a) *Maintenance Program.* A maintenance program shall be established and be based on recommendations made by the lifter manufacturer. If a qualified person determines it is appropriate, the program should also include that individual's additional recommendations based on a review of the lifter application and operations.

(b) *Maintenance Procedure*

(1) Before adjustments and repairs are started on a lifter, the following precautions shall be taken:

(-a) All sources of power shall be disconnected, locked out, and tagged "Out of Service."

(-b) A lifter removed from service for repair shall be tagged "Out of Service."

(-c) Relieve fluid pressure from all circuits before loosening or removing fluid power components.

(2) Only designated persons shall perform adjustments, repairs, and tests when required.

(3) Replacement parts shall be at least equal to the original manufacturer's specifications.

(4) After adjustments and repairs have been made, the lifter shall not be returned to service until it has been inspected according to [para. 20-1.3.4](#).

(5) Dated records of repairs and replacements should be made.

SECTION 20-1.4: OPERATION

20-1.4.1 Operators

Below-the-hook lifting devices shall be operated only by trained, designated persons.

20-1.4.2 Qualifications

(18)

Qualifications for operators of below-the-hook lifting devices are as follows:

(a) The operator shall be instructed in the use of the device by a designated person. Instructions should include, but not be limited to, the following:

(1) application of the lifter to the load and material-handling device, and adjustments, if any, that adapt the lifter to various sizes or kinds of loads

(2) instructions in any special operations or precautions

(3) the manufacturer's suggested operating procedures

(4) condition of the load itself required for operation of the lifter, such as, but not limited to, balance, surface cleanliness, flatness, bending, and load thickness

(5) storage of the lifter to protect it from damage

(6) not exceeding the rated load of the lifting device nor the capacity of the hoisting equipment by the combined weight of the load, the lifting device, and rigging

(7) the proper attachment of adapters to lifting device for special load handling

(b) The operator shall demonstrate the ability to operate the lifter as instructed before assuming responsibility for using the lifter.

(c) The operator shall demonstrate an understanding of standard hand signals when applicable.

20-1.4.3 Responsibilities

While the organizational structure of various projects may differ, the following roles are described here for purposes of delineating responsibilities. All responsibilities listed below shall be assigned in the worksite organization. (A single individual may perform one or more of these roles.)

operator: directly controls the lifting device's functions.

owner: has custodial control of a lifting device by virtue of lease or ownership.

These persons and roles may or may not match the persons and roles associated with the hoisting equipment in use.

20-1.4.3.1 Responsibilities of the Lifting Device Owner (18)

Owner. The responsibilities of the lifting device owner shall include the following:



ing a lifting device, and all necessary components provided by the manufacturer, that meets the requirements of Sections 20-1.2 and 20-1.3 as well as specific job requirements.

(b) providing all applicable operating instructions.

(c) providing field assembly, and disassembly (if applicable), operation and maintenance information, and warning decals and placards installed as prescribed by the lifting device manufacturer.

(d) establishing an inspection, testing, and maintenance program in accordance with Section 20-1.3.

(e) using designated personnel to perform the required maintenance, repair, and inspections.

(f) ensuring that the lifting device is in proper operating condition prior to initial use at the worksite by the following:

(1) verifying that all inspections have been performed as required by Section 20-1.3

(2) verifying that the lifting device has the necessary lifting capacity to perform the proposed lifting operations in the planned configuration

(g) using operators that meet the requirements of para. 20-1.4.2.

(h) ensuring that all personnel involved in maintenance, repair, assembly, disassembly, and inspection are aware of their responsibilities, assigned duties, and the associated hazards.

(i) determining if additional regulations are applicable to lifting device operations.

(j) ensuring that conditions that may adversely affect lifting device operations are addressed. Such conditions include, but are not limited to, the following:

(1) wind velocity or gusting winds

(2) precipitation

(3) fog

(4) extreme temperatures

(5) lighting

(k) addressing safety concerns raised by the operator or other personnel and being responsible if he and a qualified person decide to overrule those concerns and directs lifting device operations to continue. (In all cases, the manufacturer's criteria for safe operation and the requirements of this Volume shall be followed.)

- (18) **20-1.4.3.2 Responsibilities of Operators.** The operator shall be responsible for the following listed items. The operator shall not be responsible for hazards or conditions that are not under his direct control and that adversely affect operation of the lifting device. Whenever the operator has doubt as to the safety of lifting device operations, the operator shall place the load in a safe condition and stop the lifting device's functions in a controlled manner. Use of the lifting device shall resume only after safety concerns have been addressed or the continuation of lifting device operations is directed by the owner.

The operator's responsibilities shall include the following:

(a) reviewing the requirements for the lifting device with the owner before operations.

(b) knowing what types of site conditions could adversely affect the operation of the lifting device and consulting with the owner concerning the possible presence of those conditions.

(c) understanding and applying the information contained in the lifting device manufacturer's operating manual.

(d) understanding the lifting device's functions and limitations as well as its particular operating characteristics.

(e) ensuring an inspection is performed prior to every lift as specified in para. 20-1.3.2.

(f) promptly reporting the need for any adjustments or repairs to a designated person.

(g) following applicable lock out/tag out procedures.

(h) not operating the lifting device when physically or mentally unfit.

(i) ensuring that all controls are in the off or neutral position and that all personnel are in the clear before energizing the lifting device.

(j) not engaging in any practice that will divert his attention while operating the lifting device.

(k) testing the lifting device function controls that will be used and operating the lifting device only if those function controls respond properly.

(l) operating the lifting device's functions, under normal operating conditions, in a smooth and controlled manner.

(m) knowing and following the procedures specified by the manufacturer or approved by a qualified person, for assembly, disassembly, setting up, and reeving/rigging of the lifting device.

(n) considering all factors known that might affect the lifting device capacity and informing the owner of the need to make appropriate adjustments.

(o) understanding basic load attachment procedures.

(p) responding only to instructions from designated persons. However, the operator shall obey a stop order at all times, no matter who gives it.

(q) ensuring that all personnel shall stay clear of the load.

20-1.4.4 Lifting Device Operating Practices

(18)

(a) Lifting devices shall be operated only by the following qualified personnel:

(1) designated persons

(2) trainees under the supervision of a designated person, the number of trainees permitted to be supervised by a single designated person, the physical location of the designated person while supervising, and the type of communication required between the designated



- and the trainee shall be determined by a qualified
- (j) maintenance and test personnel, when it is necessary in the performance of their duties
 - (4) inspectors (lifting devices)
 - (b) Ensure the weight of the load and its approximate center of gravity have been obtained, provided, or calculated.
 - (c) The lifting device shall not be loaded in excess of its rated load or handle any load for which it is not designed.
 - (d) Properly attaching the lifting device to the hook, shackle, or other load handling device.
 - (e) The lifter shall be applied to the load in accordance with the instruction manual.
 - (f) Before lifting, the operator shall make sure that lifter ropes or chains are not kinked, and that multiple part lines are not twisted around each other.
 - (g) Care should be taken to make certain the load is correctly distributed for the lifter being used.
 - (h) The temperature of the load should not exceed the maximum allowable limits of the lifter.
 - (i) Verify that the load is well secured and properly balanced in the lifting device when it is initially lifted.
 - (j) Do not allow load or lifter to come into contact with any obstruction.
 - (k) The operator shall ensure that the lifting device is adequately protected from damage during use.
 - (l) The lifter shall not be used for side pulls or sliding the load unless specifically authorized by a qualified person.
 - (m) The operator shall land any attached load and store the lifter before leaving the lifting device. The operator shall not leave suspended loads unattended.

(n) The operator shall not ride, or allow others to ride loads or the lifting device.

(o) The operation of the lifter shall be observed during use. Any deficiency observed shall be examined by a designated person. If the deficiency constitutes a hazard, the lifter shall be removed from service and tagged "Out of Service." Any indication of a hazardous condition shall be reported to a qualified person for evaluation.

(p) Loads shall be guided in such a manner as to avoid endangering hands or other body parts as the load is moved, or if it drops.

20-1.4.5 Miscellaneous Operating Practices

(a) An operator shall not use a lifting device that is tagged "Out of Service" or otherwise designated as nonfunctioning.

(b) "Out of Service" tags on lifting devices shall not be removed without the approval of the person placing them or a designated person.

(c) The lifter, when not in use, should be stored at an assigned location.

(d) Caution should be taken that operating markings or tags shall not be removed or defaced. Missing or illegible markings or tags shall be replaced.

SECTION 20-1.5: INSTRUCTION MANUALS

Operating instructions and maintenance and parts information shall be furnished by the manufacturer.

آریا ایمن آوات



Chapter 20-2 Vacuum Lifting Devices

(18) SECTION 20-2.1: SCOPE

Chapter 20-2 applies to the marking, construction, installation, inspection, testing, maintenance, and operation of vacuum below-the-hook lifting devices. The provisions of Chapter 20-2 apply to all power operated and mechanically operated vacuum lifting and manipulating devices, except those vacuum lifting devices handling porous materials that require special design considerations (see Figure 20-2.1-1).

SECTION 20-2.2: MARKING, CONSTRUCTION, AND INSTALLATION

(18) 20-2.2.1 Marking

(a) *Rated Load.* The rated load of the lifter and each pad shall be legibly marked on its main structure or on a tag attached to its main structure where it is visible. This marking shall refer to the instruction manual for information relating to decreases in rating due to additional considerations.

(b) *Identification.* Vacuum lifting devices shall be marked with, but not limited to, the following information:

- (1) manufacturer's name and contact information
- (2) serial number (unique unit identifier)
- (3) lifter weight
- (4) electrical power requirements (when applicable)
- (5) pressure and volume of compressed air required (when applicable)
- (6) rated load [as described in (a)]
- (7) ASME BTH-1 Design Category
- (8) ASME BTH-1 Service Class

(c) *Repaired or Altered Lifters.* Repaired or altered vacuum lifting devices shall be provided with identification displaying, but not limited to, the following information:

- (1) name and contact information of the repairer or alterer
- (2) repairer's or alterer's unit identification
- (3) lifter weight (if altered)
- (4) electrical power requirements (if altered)
- (5) pressure and volume of compressed air required (if altered)
- (6) rated load (if altered) [as described in (a)]
- (7) ASME BTH-1 Design Category (if altered)
- (8) ASME BTH-1 Service Class (if altered)

This requirement is not applicable to repairs limited to replacement of maintenance parts.

(d) *Product Safety Labels*

(1) Where size and shape of the lifter allow, lifters shall have labels affixed to them in a readable position, that include the appropriate signal word, according to ANSI Z535.4-2011, to bring the label to the attention of the operator. The label should include cautionary language identifying hazards, methods for accident prevention, and refer to instruction manuals for additional information.

(2) Where size or shape of lifter prohibits the inclusion of all or any such markings, a label shall be affixed, referring user to consult manufacturer's instruction manual for product safety information.

(e) *Operating Controls*

(1) If the vacuum lifting device has manual shutoff valves that control pads or groups of pads, the valves shall be marked to show operating position. Should this marking be some type of coding, then a label or tag shall be attached at or near the valve that explains such markings.

(2) Each control shall be clearly marked describing resulting motion or function of the lifter.

20-2.2.2 Construction

(18)

(a) *Vacuum Lifter Design.* The manufacturer shall verify that vacuum lifting devices are designed by or under the supervision of a qualified person. The design shall be in accordance with ASME BTH-1.

(b) *Welding.* Welding shall be in accordance with ASME BTH-1, para. 1-4.6.

(c) *Electrical Equipment.* External power supply, electrical equipment, and wiring for below-the-hook lifters shall be in accordance with ASME BTH-1.

(d) *Alterations.* Vacuum lifters may be altered or rerated, provided such alterations are analyzed and approved by the equipment manufacturer or a qualified person. A rerated lifter or one whose components have been altered shall conform to this paragraph and be tested according to para. 20-2.3.8. The new rated load shall be displayed in accordance with para. 20-2.2.1(a).

(e) *Slings.* When employed, slings shall meet the requirements of ASME B30.9.

(f) *Hooks.* When employed, hooks shall meet the requirements of ASME B30.10

Figure 20-2.1-1 Vacuum Lifters

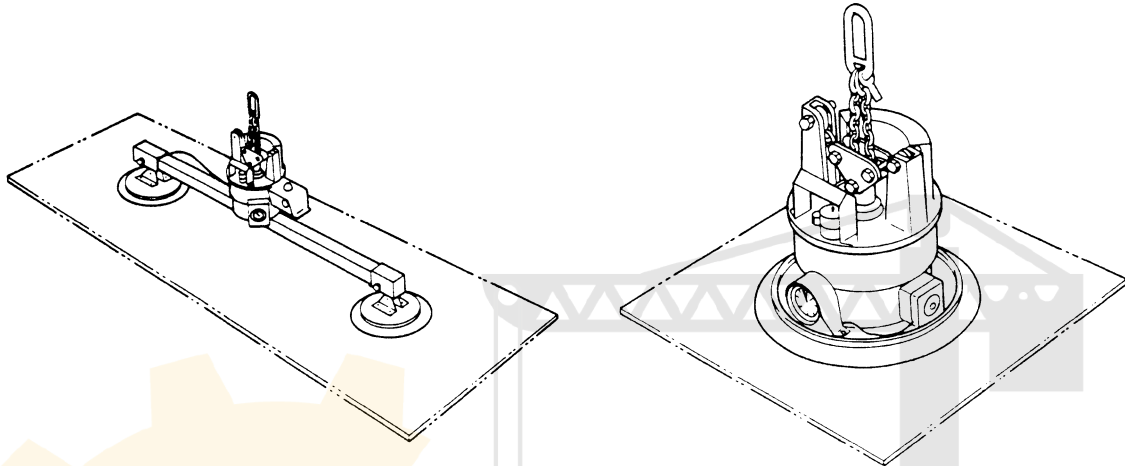

(a) Two-Pad Mechanical Vacuum Lifter

(b) Single-Pad Mechanical Vacuum Lifter

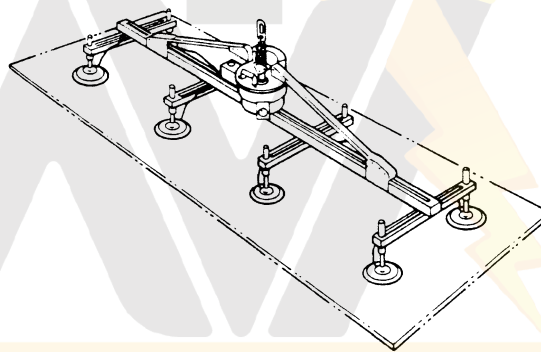

(c) Multiple-Pad Mechanical Vacuum Lifter

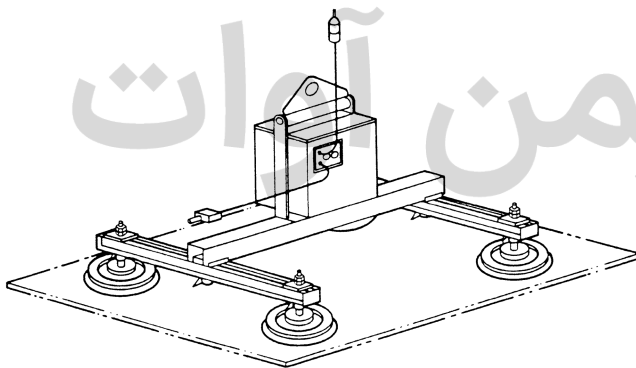

(d) Four-Pad Powered Vacuum Lifter

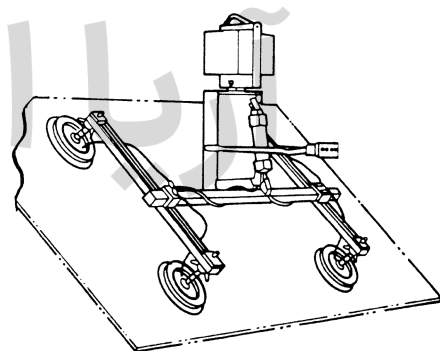

(e) Four-Pad Powered Vacuum Lifter Manipulator



Hardware. When employed, rigging hardware shall meet the requirements of ASME B30.26.

20-2.3.3 Installation

(a) The vacuum lifting device shall be assembled and installed in accordance with the manufacturer's instructions.

(b) The installer shall ensure that the power supply is the same as that shown on the nameplate.

(c) The electrical power supply to the vacuum lifter shall be connected to the line side of the crane disconnect or to an independent circuit.

(d) The installer shall check for correct rotation of all motors.

(e) Prior to initial use, the lifter shall be tested per [para. 20-2.3.8](#).

(f) Operating instructions, maintenance, and parts information shall be furnished by the manufacturer.

(g) External power supply and electrical equipment for below-the-hook lifters shall comply with NFPA 70.

SECTION 20-2.3: INSPECTION, TESTING, AND MAINTENANCE

(18) 20-2.3.1 Inspection Classification

General. All inspections shall be performed by a designated person. Any deficiencies identified shall be examined and a determination made by a qualified person as to whether they constitute a hazard, and if so, what additional steps need to be taken to address the hazard.

Inspection of slings (ASME B30.9), hooks (ASME B30.10), rigging hardware (ASME B30.26), or other special devices shall comply with the inspection requirements in the applicable volume.

(a) Initial Inspection

(1) New and reinstalled vacuum lifters shall be inspected prior to initial use to verify compliance with applicable provisions of this Volume.

(2) Altered or repaired vacuum lifters shall be inspected. The inspection may be limited to the components affected by the alteration or repair, as determined by a qualified person.

(b) *Inspection Intervals.* Inspection procedure for vacuum lifting devices in regular service is divided into three general classifications, based upon the intervals at which inspection should be performed. The intervals, in turn, are dependent upon the nature of the critical components of the vacuum lifting device and the degree of their exposure to wear, deterioration, or malfunction. The three general classifications are designated as *every lift*, *frequent*, and *periodic*, with respective intervals between inspections as defined below.

(1) *Every Lift Inspection.* Visual examination by the operator before and during each lift made by the vacuum lifting device.

(2) *Frequent Inspection.* Visual examinations by the operator or other designated persons with records not required.

(-a) Normal service — monthly

(-b) Heavy service — weekly to monthly

(-c) Severe service — daily to weekly

(-d) Special or infrequent service — as recommended by a qualified person before and after each lift

(3) *Periodic Inspection.* Visual inspection making records of apparent external conditions to provide the basis for a continuing evaluation. An external coded mark on the vacuum lifting device is an acceptable identification in lieu of records.

(-a) Normal service for equipment in place — yearly

(-b) Heavy service — semiannually

(-c) Severe service — quarterly

(-d) Special or infrequent service — as recommended by a qualified person before the first lift and as directed by the qualified person for any subsequent lifts

20-2.3.2 Every Lift Inspection

Items such as the following shall be inspected by the operator before and/or during every lift for any indication of damage as specifically indicated, including observations during operation for any damage that might occur during the lift:

(a) surface of the load for debris

(b) seal of the vacuum pad for debris

(c) condition and operation of the controls

(d) condition and operation of the indicators, meters, and pumps when installed

20-2.3.3 Frequent Inspection

Items such as the following shall be inspected for damage at intervals as defined in [para. 20-2.3.1\(b\)\(2\)](#), including observations during operation for any indications of damage that might appear between inspections. A qualified person shall determine whether any indications of damage constitute a hazard or will require more frequent inspection. For all vacuum lifters, inspect

(a) structural members for deformation, cracks, and excessive wear on any part of the lifter.

(b) the vacuum generator for output.

(c) all vacuum pad seal rings for cuts, tears, excessive wear, and presence of foreign particles.

(d) all vacuum lines and vacuum line connections for leakage, cuts, kinks, and collapsed areas of hoses.

(e) the vacuum reservoir for leaks and visual damage.

(f) the entire vacuum system, including indicator lights, gages, horns, bells, pointers or other warning devices, and vacuum level indicators, by attaching a nonporous, clean surface to the vacuum pad or pads and then stopping the vacuum source. The vacuum level in the system shall not decrease by more than the manufacturer's specified rate.

(g) missing or illegible operating control markings.



Periodic Inspection

Complete inspections of the vacuum lifting device shall be performed at intervals as defined in [para. 20-2.3.1\(b\)](#) (3). Any deficiencies, such as listed below, shall be examined, and determination made as to whether they constitute a hazard. These inspections shall include the requirements of [para. 20-2.3.3](#) and, in addition, items such as the following:

- (a) external evidence of
 - (1) looseness
 - (2) wear
 - (3) deformation
 - (4) cracking
 - (5) corrosion
- (b) external evidence of damage to
 - (1) supporting structure
 - (2) motors
 - (3) controls
 - (4) other auxiliary components
- (c) missing or illegible product safety labels required by [para. 20-2.2.1\(d\)](#)

20-2.3.5 Vacuum Lifters Not in Regular Use

A vacuum lifter that has been idle for a period of 1 month to 1 yr shall be inspected in accordance with [para. 20-2.3.3](#) before being placed in service. A vacuum lifter that has been idle for a period of 1 yr or more shall be inspected in accordance with [para. 20-2.3.4](#) before being returned to service.

20-2.3.6 Inspection Records

Dated inspection reports shall be made on critical items such as those listed in [para. 20-2.3.4](#). Records should be available for each periodic inspection and when the vacuum lifter is either altered or repaired.

(18) 20-2.3.7 Repairs

Damage disclosed by the inspection requirements of [Section 20-2.3](#) shall be corrected according to the procedures outlined in [para. 20-2.3.9](#) before operation of the vacuum lifter is resumed, unless a qualified person determines the damage does not constitute a hazard. Repairs of slings (ASME B30.9), hooks (ASME B30.10), rigging hardware (ASME B30.26), or other special devices shall comply with repair requirements in the applicable volumes or standards.

20-2.3.8 Testing

(18) 20-2.3.8.1 Operational Tests

(a) New and reinstalled lifting devices shall be tested by, or under the direction of the manufacturer or a qualified person prior to initial use to verify compliance with applicable provisions of this Volume, including, but not limited to, the following:

- (1) moving parts
- (2) latches
- (3) stops
- (4) limit switches
- (5) control devices
- (6) vacuum pad seals
- (7) vacuum lines

(b) Altered or repaired lifting devices shall be tested by a qualified person, or a designated person under the direction of the manufacturer or a qualified person. This test may be limited to the components affected by the alteration or repair, as determined by a qualified person with guidance from the manufacturer.

(c) The seals and connections shall be tested for leaks by attaching a smooth, nonporous, clean material to the vacuum pad or pads and then stopping the vacuum source. Vacuum level in the system shall not decrease by more than the manufacturer's specified rate.

(d) All indicator lights, gages, horns, bells, pointers, and other warning devices and vacuum level indicators shall be tested by the same method as in [para. 20-2.3.8.2](#) below.

(e) Dated reports of all operational tests shall be filed.

20-2.3.8.2 Load Test

(18)

(a) Prior to initial use, all new, altered, or repaired vacuum lifting devices shall be load tested and inspected by a qualified person, or a designated person under the direction of the manufacturer or a qualified person. A written report shall be prepared by the qualified person and placed on file, confirming the load rating of the vacuum lifting device. The load rating should not be more than 80% of the maximum load sustained during the test. Test loads shall not be more than 125% of the rated load of the system, unless otherwise recommended by the manufacturer or a qualified person.

(b) Altered or repaired vacuum lifting devices shall be tested by, or under the direction of, a qualified person. This test may be limited to the components affected by the alteration or repair, as determined by a qualified person with guidance from the manufacturer.

(c) The load test shall consist of one of the following procedures:

(1) Actual Load Test

(-a) Attach pads to the designated test load.

(-b) Raise the test load a minimum distance to ensure the load is supported by the vacuum lifting device.

(-c) Hold the load for 2 min.

(-d) Lower the load for release.

(2) Simulated Load Test. Using a test fixture, apply forces to all load-bearing components, either individually or in assemblies, equivalent to the force encountered by the components if they were supporting a load that was 125% of the rated load.

(d) After the test, the vacuum lifting device shall be visually inspected. Any condition that constitutes a hazard shall be corrected before the lifting device is



vice. If the correction affects the structure, the device shall be retested.

(18) 20-2.3.9 Maintenance

(a) *Maintenance Program.* A maintenance program shall be established and be based on recommendations made by the vacuum lifting device manufacturer. If a qualified person determines it is appropriate, the program should also include that individual's additional recommendations based on a review of the vacuum lifting device application and operations.

(b) *Maintenance Procedure*

(1) Before adjustments and repairs are started on a vacuum lifting device, the following precautions shall be taken:

(-a) Locate the vacuum lifting device where it will cause the least interference with other operations in the area.

(-b) All sources of power shall be disconnected, locked out, and tagged "Out of Service."

(-c) Relieve fluid pressure from all circuits before loosening or removing fluid power components.

(2) Only designated personnel shall perform adjustments, repairs, and tests when required.

(-a) Provisions should be made for designated persons to work on energized equipment when adjustments and tests are required.

(-b) All moving parts of the vacuum lifting device for which lubrication is specified should be regularly lubricated. The manufacturer's recommendations as to points and frequency of lubrication, maintenance of lubrication levels, and types of lubricant should be used.

(-c) Adjustments shall be maintained to assure correct functioning of components.

(-d) Repairs or replacements shall be made as needed.

(3) Replacement parts shall be at least equal to the original manufacturer's specifications.

(4) After adjustments and repairs have been made, the vacuum lifting device shall not be returned to service until it has been inspected according to [para. 20-2.3.4](#).

(5) Dated records of repairs and replacements should be made.

SECTION 20-2.4: OPERATION

20-2.4.1 Operators

Below-the-hook lifting devices shall be operated only by trained, designated persons.

(18) 20-2.4.2 Qualifications

Qualifications for operators of below-the-hook lifting devices are as follows:

(a) The operator shall be instructed in the use of the device by a designated person. Instructions should include, but not be limited to, the following:

(1) application of the lifter to the load and material-handling device, and adjustments, if any, that adapt the lifter to various sizes or kinds of loads

(2) instructions in any special operations or precautions

(3) the manufacturer's suggested operating procedures

(4) condition of the load required for operation of the lifter, such as, but not limited to, balance, surface cleanliness, flatness, bending, and load thickness

(5) storage of the lifter to protect it from damage

(6) not exceeding the rated load of the lifting device nor the capacity of the hoisting equipment by the combined weight of the load, the lifting device, and rigging

(7) charging of the battery (if required)

(8) the purpose of indicators, meters, or alarms on the vacuum lifter

(9) the proper attachment of adapters to lifting device for special load handling

(b) The operator shall demonstrate the ability to operate the lifter as instructed before assuming responsibility for using the lifter.

(c) The operator shall demonstrate an understanding of standard hand signals when applicable.

20-2.4.3 Responsibilities

While the organizational structure of various projects may differ, the following roles are described here for purposes of delineating responsibilities. All responsibilities listed below shall be assigned in the worksite organization. (A single individual may perform one or more of these roles.)

operator: directly controls the lifting device's functions.

owner: has custodial control of a lifting device by virtue of lease or ownership.

These persons and roles may or may not match the persons and roles associated with the hoisting equipment in use.

20-2.4.3.1 Responsibilities of the Lifting Device (18)

Owner. The responsibilities of the lifting device owner shall include the following:

(a) providing a lifting device, and all necessary components specified by the manufacturer, that meets the requirements of [Sections 20-2.2](#) and [20-2.3](#) as well as specific job requirements.

(b) providing all applicable operating instructions.

(c) providing field assembly, and disassembly (if applicable), operation and maintenance information, and warning decals and placards installed as prescribed by the lifting device manufacturer.



establishing an inspection, testing, and maintenance program in accordance with [Section 20-2.3](#).
using designated personnel to perform the required maintenance, repair, and inspections.

(f) ensuring that the lifting device is in proper operating condition prior to initial use at the worksite by the following:

(1) verifying that all inspections have been performed as required by [Section 20-2.3](#)

(2) verifying that the lifting device has the necessary lifting capacity to perform the proposed lifting operations in the planned configuration

(g) using operators that meet the requirements of [paras. 20-2.4.2](#).

(h) ensuring that all personnel involved in maintenance, repair, assembly, disassembly, and inspection are aware of their responsibilities, assigned duties, and the associated hazards.

(i) determining if additional regulations are applicable to lifting device operations.

(j) ensuring that conditions that may adversely affect lifting device operations are addressed. Such conditions include, but are not limited to, the following:

(1) wind velocity or gusting winds

(2) precipitation

(3) fog

(4) extreme temperatures

(5) lighting

(k) addressing safety concerns raised by the operator or other personnel and being responsible if he and a qualified person decide to overrule those concerns and directs lifting device operations to continue. (In all cases, the manufacturer's criteria for safe operation and the requirements of this Volume shall be followed.)

- (18) **20-2.4.3.2 Responsibilities of Operators.** The operator shall be responsible for the following listed items. The operator shall not be responsible for hazards or conditions that are not under his direct control and that adversely affect operation of the lifting device. Whenever the operator has doubt as to the safety of lifting device operations, the operator shall place the load in a safe condition and stop the lifting device's functions in a controlled manner. Use of the lifting device shall resume only after safety concerns have been addressed or the continuation of lifting device operations is directed by the owner.

The operator's responsibilities shall include the following:

(a) reviewing the requirements for the lifting device with the owner before operations.

(b) knowing what types of site conditions could adversely affect the operation of the lifting device and consulting with the owner concerning the possible presence of those conditions.

(c) understanding and applying the information contained in the lifting device manufacturer's operating manual.

(d) understanding the lifting device's functions and limitations as well as its particular operating characteristics.

(e) ensuring an inspection is performed prior to every lift as specified in [para. 20-2.3.2](#).

(f) promptly reporting the need for any adjustments or repairs to a designated person.

(g) following applicable lock out/tag out procedures.

(h) not operating the lifting device when physically or mentally unfit.

(i) ensuring that all controls are in the off or neutral position and that all personnel are in the clear before energizing the lifting device.

(j) not engaging in any practice that will divert his attention while operating the lifting device.

(k) testing the lifting device function controls that will be used and operating the lifting device only if those function controls respond properly.

(l) operating the lifting device's functions, under normal operating conditions, in a smooth and controlled manner.

(m) knowing and following the procedures specified by the manufacturer or approved by a qualified person, for assembly, disassembly, setting up, and reeving/rigging of the lifting device.

(n) considering all factors known that might affect the lifting device capacity and informing the owner of the need to make appropriate adjustments.

(o) understanding basic load attachment procedures.

(p) responding only to instructions from designated persons. However, the operator shall obey a stop order at all times, no matter who gives it.

(q) ensuring that all personnel shall stay clear of the load.

20-2.4.4 Lifting Device Operating Practices

(18)

(a) Lifting devices shall be operated only by the following qualified personnel:

(1) designated persons

(2) trainees under the supervision of a designated person, the number of trainees permitted to be supervised by a single designated person, the physical location of the designated person while supervising, and the type of communication required between the designated person and the trainee shall be determined by a qualified person.

(3) maintenance and test personnel, when it is necessary in the performance of their duties

(4) inspectors (lifting devices)

(b) Ensure the weight of the load and its approximate center of gravity have been obtained, provided, or calculated.



ng device shall not be loaded in excess of its handle any load for which it is not designed. properly attaching the lifting device to the hook, snackle, or other load handling device.

(e) The lifter shall be applied to the load in accordance with the instruction manual.

(f) Before lifting, the operator shall make sure that lifter ropes or chains are not kinked, and that multiple part lines are not twisted around each other.

(g) Care should be taken to make certain the load is correctly distributed for the lifter being used.

(h) The temperature of the load should not exceed the maximum allowable limits of the lifter.

(i) Verify that the load is well secured and properly balanced in the lifting device when it is initially lifted.

(j) Do not allow the load to come into contact with any obstruction.

(k) The operator shall ensure that the lifting device is adequately protected from damage during use.

(l) The lifter shall not be used for side pulls or sliding the load unless specifically authorized by a qualified person.

(m) If power goes off while making a lift, the operator shall immediately warn all persons in the vicinity of the lifter and land the load if at all possible to do so.

(n) The vacuum lines shall be free from kinks and twists, and shall not be wrapped around or looped over portions of the lifter that will move during the lift.

(o) The pad contact surface shall be clean and free of loose particles.

(p) Before starting to lift, verify that the vacuum level indicator has reached the required level.

(q) Before starting to lift, raise the load a few inches to establish that the vacuum lifting device has been correctly applied and that a stable vacuum level exists.

(r) The operator shall land any attached load and store the lifter before leaving the lifting device. The operator shall not leave suspended loads unattended.

(s) The operator shall not ride, or allow others to ride loads or the lifting device.

(t) The operation of the lifter shall be observed during use. Any deficiency observed shall be examined by a designated person. If the deficiency constitutes a hazard, the lifter shall be removed from service and tagged "Out of Service." Any indication of a hazardous condition shall be reported to a qualified person for evaluation.

(u) Loads shall be guided in such a manner as to avoid endangering hands or other body parts as the load is moved, or if it drops.

20-2.4.5 Miscellaneous Operating Practices

(a) An operator shall not use a lifting device that is tagged "Out of Service" or otherwise designated as nonfunctioning.

(b) "Out of Service" tags on lifting devices shall not be removed without the approval of the person placing them or a designated person.

(c) The lifter, when not in use, should be stored at an assigned location.

(d) Caution should be taken that operating markings or tags shall not be removed or defaced. Missing or illegible markings or tags shall be replaced.

SECTION 20-2.5: INSTRUCTION MANUALS

The manufacturer shall provide operating instructions, and maintenance and parts information. In addition, the manual shall also provide a statement of those factors that alter the vacuum lifter's lifting capacity and related limitations. Several factors known to affect the vacuum lifter's lifting capacity are noted below.

(a) *Load Rigidity.* The rigidity may cause the vacuum pads and the structure to be loaded unevenly. The rigidity may vary depending on orientation.

(b) *Load Strength.* Stress induced by the load's own weight and the stress from the vacuum pads may damage the load.

(c) *Load Surface Conditions.* Uneven or rough surfaces may affect the vacuum pad's ability to attach or maintain a seal. Frictional properties may affect the capacity.

(d) *Load Overhang.* As the load extends past the supports of the vacuum pads, the load may be damaged or deflect and peel away from the pad seal.

(e) *Angle of the Load.* The effect of the coefficient of friction between the load and vacuum pad becomes significant when the load is not horizontal.

(f) *Number of Pads Attached to the Load.* The capacity varies with the number of pads fully attached to the load.

(g) *Load Temperature.* Elevated temperatures may damage the vacuum pads or affect the function of the pads.

(h) *Elevation and Vacuum Level.* The vacuum pad rating varies with the vacuum level achieved under the pads. If the vacuum level decreases from the vacuum level used for capacity calculations, the ultimate pad capacity is reduced. At various elevations, the vacuum level that can be reached may vary.



Chapter 20-3

Close Proximity Operated Lifting Magnets

SECTION 20-3.1: SCOPE

Chapter 20-3 applies to the marking, construction, installation, inspection, testing, maintenance, and operation of all lifting magnets when used for single or multiple steel piece handling operations in which the operator of the lifting magnet is required to manually position the lifting magnet on the load and manually guide the load during its movement, or in remotely operated lifting magnets when operated in close proximity to people. For multi-magnet systems where individual lifting magnets are suspended from a spreader beam or its equivalent, this section applies only to the individual lifting magnet, excluding the spreader beam or its equivalent and the associated control equipment (see Figure 20-3.1-1). This Chapter does not apply to remotely operated lifting magnets in areas where people are excluded during normal operation.

SECTION 20-3.2: MARKING, CONSTRUCTION, AND INSTALLATION

(18) 20-3.2.1 Marking

(a) Rated Load

(1) *General Application Lifting Magnets.* The rated load of the lifting magnet shall be legibly marked on the lifting magnet or on a tag attached to the lifting magnet where it is visible. This marking shall refer to the instruction manual for information relating to decreases in rating due to the load surface condition, thickness, percentage of contact with the lifting magnet, temperature, metallurgical composition, and deflection.

(2) *Specified Application Lifting Magnets.* The rated load of the lifting magnet shall be legibly marked on the lifting magnet or on a tag attached to the lifting magnet where it is visible. This marking shall describe the specific loads for which this rating applies.

(b) *Identification.* Close proximity operated lifting magnets shall be provided with identification displaying, but not limited to, the following information:

- (1) manufacturer's name and contact information
- (2) serial number (unique unit identifier)
- (3) weight of lifting magnet
- (4) duty cycle (when applicable)
- (5) the cold current (amps) at 68°F (20°C) (when applicable)

(6) the voltage of the primary power supply or battery (when applicable)

(7) rated load [as described in (a)]

(8) ASME BTH-1 Design Category B

(9) ASME BTH-1 Service Class

(c) *Repaired or Altered Lifting Magnets.* Repaired or altered magnets shall be provided with identification displaying, but not limited to, the following information:

(1) name and address of the repairer or alterer

(2) repairer's or alterer's unit identification

(3) weight of lifting magnet (if altered)

(4) duty cycle (if altered)

(5) the cold current or wattage at 68°F (20°C) (if altered)

(6) the voltage of the primary power supply or battery (if altered)

(7) rated load (if altered) [as described in (a)]

(8) ASME BTH-1 Design Category B

(9) ASME BTH-1 Service Class (if altered)

This requirement is not applicable to repairs limited to replacement of maintenance parts.

(d) *Product Safety Labels*

(1) Where size and shape of the lifter allow, lifters shall have labels affixed to them in a readable position, that include the appropriate signal word, according to ANSI Z535.4-2011, to bring the label to the attention of the operator. The label should include cautionary language identifying hazards, methods for accident prevention, and refer to instruction manuals for additional information.

(2) Where size or shape of lifting magnet prohibits the inclusion of all or any such markings, a label shall be affixed, referring user to consult manufacturer's instruction manual for product safety information.

(3) Labels on battery operated lifting magnets shall provide additional cautionary language about operating when the battery capacity is inadequate.

(4) Labels on externally powered electromagnets shall contain additional cautionary language against

(-a) exceeding lifting magnet duty cycle

(-b) disconnecting lifting magnet with power on

(5) Labels on electrically controlled permanent magnets shall contain additional cautionary language about operating if the internal control function indicator, where applicable, does not indicate a complete cycle.

Figure 20-3.1-1 Close Proximity Operated Magnetic Lifters

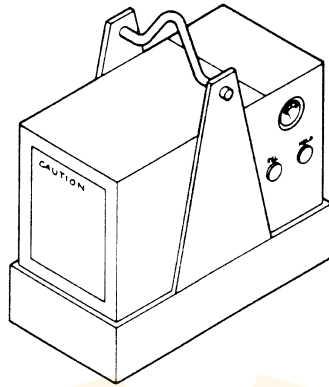

(a) Close Proximity Operated Battery-Powered Lifting Electromagnet

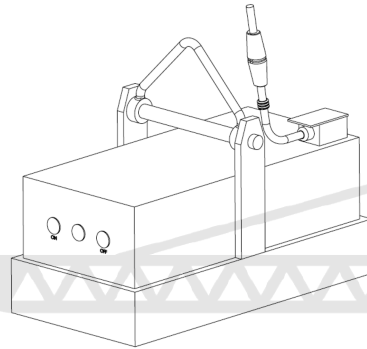

(b) Close Proximity Operated Electrically Controlled Permanent Magnet

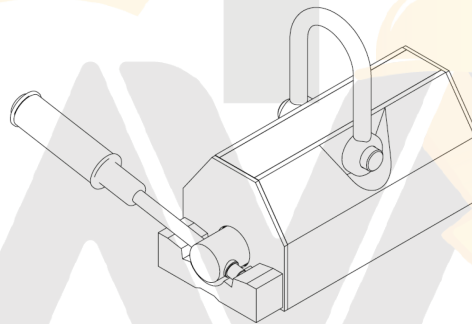

(c) Close Proximity Operated Manually Controlled Permanent Magnet

(6) Labels on manually controlled permanent magnets shall contain additional precautionary language about operating with the control handle latch not fully in the “attach” position.

(e) *Operating Controls.* Each control shall be clearly marked describing resulting motion or function of the lifter.

(18) **20-3.2.2 Construction**

(a) *General*

(1) *Lifter Design.* The manufacturer shall verify that close proximity operated lifting magnets are designed in accordance with ASME BTH-1. Close proximity lifting magnets shall be designed to ASME BTH-1 Design Category B (static strength criteria) and the proper Service Class (fatigue life criteria) selected for the number of load cycles.

(2) *Welding.* Welding shall be in accordance with ASME BTH-1, para. 1-4.6.

(b) *Electrical Equipment.* External power supply, electrical equipment, and wiring for electromagnets shall be in accordance with ASME BTH-1.

(c) *Lifting Magnet Controllers.* Lifting magnet controllers should have voltage and amperage indicators (when applicable).

(d) *Power Disconnects.* Disconnects are not required on externally powered electromagnets operating from a 120 VAC single-phase power source.

(e) *Alterations.* Lifting magnets may be altered or rerated, provided such alterations and the supporting structure are analyzed and approved by the lifting magnet manufacturer or a qualified person. A rerated lifting magnet or one whose load-supporting components have been altered shall conform to (a)(1) and be tested in accordance with para. 20-3.3.8. New rated load and application load shall be displayed in accordance with para. 20-3.2.1.

(f) *Slings.* When employed, slings shall meet the requirements of ASME B30.9.

(g) *Hooks.* When employed, hooks shall meet the requirements of ASME B30.10.



ging Hardware. When employed, rigging hardware shall meet the requirements of ASME B30.26.

20-3.2.3 Installation

(a) The lifting magnet shall be installed in accordance with the manufacturer's instructions.

(b) Determine that the external power input is in accordance with paras. 20-3.2.2(b) and 20-3.2.2(f), is of the correct voltage and amperage, and that the power conductors and controls are of adequate rating, and insulated and protected against accidental interruption or damage.

SECTION 20-3.3: INSPECTION, TESTING, AND MAINTENANCE

(18) 20-3.3.1 Inspection Classification

General. All inspections shall be performed by a designated person. Any deficiencies identified shall be examined and a determination made by a qualified person as to whether they constitute a hazard, and if so, what additional steps need to be taken to address the hazard.

Inspection of slings (ASME B30.9), hooks (ASME B30.10), rigging hardware (ASME B30.26), or other special devices shall comply with the inspection requirements in the applicable volume.

(a) Initial Inspection

(1) New and reinstalled lifting magnets shall be inspected prior to initial use to verify compliance with applicable provisions of this Volume.

(2) Altered or repaired lifting magnets shall be inspected. The inspection may be limited to the components affected by the alteration or repair, as determined by a qualified person.

(b) *Inspection Intervals.* Inspection procedures for lifting magnets in regular service are divided into three general classifications, based upon the intervals at which the inspections shall be performed. The intervals, in turn, are dependent upon the nature of the critical components of the lifting magnet and the degree of their exposure to wear, deterioration, or malfunction. The three general classifications are designated as *every lift*, *frequent*, and *periodic*, with respective intervals between inspections as defined below.

(1) *Every Lift Inspection.* Visual examination by the operator before and during each lift made by the lifting magnet.

(2) *Frequent Inspection.* Visual examination by the operator or other designated persons with records not required.

(-a) Normal service — monthly

(-b) Heavy service — weekly to monthly

(-c) Severe service — daily to weekly

(-d) Special or infrequent service — as recommended by a qualified person before and after each lift

(3) *Periodic Inspection.* Visual inspection making records of apparent external conditions to provide the basis for a continuing evaluation.

(-a) Normal service for equipment in place — yearly

(-b) Heavy service for equipment in place — quarterly

(-c) Severe service — monthly

(-d) Special or infrequent service — as recommended by a qualified person before the first lift and as directed by the qualified person for any subsequent lifts

20-3.3.2 Every Lift Inspection

Items such as the following shall be inspected by the operator before and/or during every lift for any indication of damage as specifically indicated, including observations during operation for any damage that might occur during the lift:

(a) lifting magnet face and surface of the load for foreign materials and smoothness

(b) condition and operation of the control handle of a manually controlled permanent magnet

(c) condition and operation of indicators and meters when installed

20-3.3.3 Frequent Inspection

Items such as the following shall be inspected for damage at intervals as defined in para. 20-3.3.1(b)(2), including observations during operation for any indications of damage that might appear between inspections. A qualified person shall determine whether any indications of damage constitute a hazard or will require more frequent inspection. For all lifting magnets, inspect

(a) structural and suspension members for deformation, cracks, or excessive wear on any part of the lifting magnet

(b) lifting magnet face for foreign materials and smoothness

(c) condition of lifting bail or sling suspension

(d) condition and operation of control handle

(e) condition and operation of indicators and meters, where applicable

(f) for all lifting magnets, except manually controlled permanent magnets, inspect all electrical conductors that are visible without disassembly for loose connections, continuity, corrosion, and damage to insulation

(g) for battery operated electromagnets, inspect for proper level of battery electrolyte and for corrosion of either the battery posts or connectors

(h) cracked housings, welds, and loose bolts

(i) labels and markings

(j) missing or illegible operating control markings



Periodic Inspection

The inspections of lifting magnets shall be performed and recorded at intervals as defined in [para. 20-3.3.1\(b\)\(3\)](#). Any deficiencies, such as those listed below, shall be examined by a qualified person and determination made as to whether they constitute a hazard. These inspections shall include the requirements of [para. 20-3.3.3](#) and, in addition, items such as the following:

(a) All members, fasteners, locks, switches, warning labels, and lifting parts shall be inspected for deformation, wear, and corrosion.

(b) All electrical components described in [paras. 20-3.2.2\(b\)](#) through [20-3.2.2\(f\)](#), including meters, indicators, or alarms, shall be tested for proper operation and condition.

(c) The lifting magnet coil shall be tested for ohmic and ground readings and compared to manufacturer's standards.

(d) missing or illegible product safety labels required by [para. 20-3.2.1\(d\)](#).

20-3.3.5 Lifting Magnets Not in Regular Use

A lifting magnet that has been idle for a period of 1 month to 1 yr shall be inspected in accordance with [para. 20-3.3.3](#) before being placed in service. A lifting magnet that has been idle for a period of 1 yr or more shall be inspected in accordance with [para. 20-3.3.4](#) before being returned to service.

20-3.3.6 Inspection Records

Dated inspection reports shall be made on critical items, such as those listed in [para. 20-3.3.4](#). Records should be available for each periodic inspection and when the lifting magnet is either altered or repaired.

(18) 20-3.3.7 Repairs

Damage disclosed by the inspection requirements of [Section 20-3.3](#) shall be corrected according to the procedures outlined in [para. 20-3.3.9](#) before operation of the lifting magnet is resumed, unless a qualified person determines the damage does not constitute a hazard. Repairs of slings (ASME B30.9), hooks (ASME B30.10), rigging hardware (ASME B30.26), or other special devices shall comply with repair requirements in the applicable volumes or standards.

20-3.3.8 Testing

(18) 20-3.3.8.1 Operational Tests

(a) New and reinstalled lifting magnets shall be tested by a qualified person, or a designated person under the direction of the manufacturer or a qualified person, prior to initial use to verify compliance with applicable provisions

of this Volume, including, but not limited to, the following:

- (1) moving parts
- (2) latches
- (3) stops
- (4) switches
- (5) any control devices
- (6) alarms

(b) Altered or repaired lifting magnets shall be tested by a qualified person, or a designated person under the direction of the manufacturer or a qualified person. The test may be limited to the components affected by the alteration or repair, as determined by a qualified person with guidance from the manufacturer.

(c) All indicator lights, gages, horns, bells, alarms, pointers, and other warning devices shall be tested.

(d) Dated reports of all operational tests shall be filed.

20-3.3.8.2 Load Test

(18)

(a) Prior to initial use, all new, altered, or repaired lifting magnets shall be tested by, or under the direction of the manufacturer or a qualified person. The rated load of all lifting components associated with the magnet shall exceed the maximum breakaway force of the magnet to avoid overload, or the components shall not be included in the test. The test results shall be recorded confirming the load rating of the lifting magnet.

(1) Breakaway Force Test

(-a) General application lifting magnets shall be required to satisfy the rated breakaway force test.

(-1) The rated load for permanent magnet lifters shall be less than 33% of the breakaway force measured in this test.

(-2) The rated load for electromagnetic lifters shall be less than 50% of the breakaway force measured in this test.

(-b) Specified application lifting magnets shall be required to satisfy the specified application lifting magnet breakaway force test.

(-1) The rated load for permanent magnet lifters shall be less than 33% of the breakaway force measured in this test.

(-2) The rated load for electromagnetic lifters shall be less than 50% of the breakaway force measured in this test.

(2) *Design Factor Test.* Close proximity operated lifting magnets should have an annual magnetic design factor test to verify the magnet meets [para. 20-3.3.8.2](#). This test should be performed to the actual breakaway point of the magnet or may be performed at the calculated minimum breakaway force. The rated load of all components associated with the (magnetic) design factor test shall exceed the maximum breakaway load of the magnet to avoid overload or the lifting hardware shall be removed. Caution should be exercised during the



test shall be performed under the direction of a qualified person.

The general application lifting magnet breakaway force test shall establish the force required to vertically remove the lifting magnet from a low carbon, rolled steel plate of the minimum thickness stated by the lifting magnet manufacturer. The portion of this plate that is in contact with the lifting magnet shall not exceed 125 $\mu\text{in.}$ (3.2×10^{-3} mm) or better and be flat within 0.002 in./ft (0.05 mm/m), without exceeding 0.005 in. (0.127 mm) total. The full operating face of the lifting magnet shall be in contact with the steel plate, which shall be between 60°F (15°C) and 120°F (50°C). The steel plate, load cell, or other testing device shall be mounted to allow self-alignment so the load is applied to the magnet through the magnet's center of force.

(c) The specified application lifting magnet breakaway force test shall establish the breakaway forces of the lifting magnet under the variety of loading conditions for which the lifting magnet is specified. The details of this test should be supplied by the manufacturer of the lifting magnet.

(d) Battery operated electromagnets and externally powered electromagnets shall be operated at the manufacturer's recommended voltage and current levels.

(e) The test for altered or repaired lifting magnets may be limited to the components affected by the alteration or repair, as determined by a qualified person with guidance from the manufacturer.

(18) 20-3.3.9 Maintenance

(a) *Maintenance Program.* A maintenance program shall be established and be based on recommendations made by the lifting magnet manufacturer. If a qualified person determines it is appropriate, the program should also include that individual's additional recommendations based on a review of the lifting magnet application and operations.

(b) *Maintenance Procedure*

(1) Before adjustment and repairs are started on a lifting magnet or its controls, the following precautions shall be taken:

(-a) All sources of lifting magnet power shall be disconnected, locked out, and tagged "Out of Service."

(-b) A lifting magnet removed for repair shall be tagged "Out of Service."

(-c) Relieve fluid pressure from all circuits before loosening or removing fluid power components.

(2) Only designated personnel shall work on equipment when adjustments, repairs, and tests are required.

(3) Replacement parts shall be at least equal to the original manufacturer's specifications.

(4) After adjustments and repairs have been made, the lifting magnet shall not be returned to service until it has been inspected according to [para. 20-3.3.4](#).

(5) Dated records of repairs and replacements should be made.

SECTION 20-3.4: OPERATION

20-3.4.1 Operators

Below-the-hook lifting devices shall be operated only by a trained, designated person.

20-3.4.2 Qualifications

(18)

Qualifications for operators of below-the-hook lifting devices are as follows:

(a) The operator shall be instructed in the use of the device by a designated person. Instructions should include, but not be limited to, the following:

(1) application of the lifter to the load and material-handling device, and adjustments, if any, that adapt the lifter to various sizes or kinds of loads

(2) instructions in any special operations or precautions

(3) the manufacturer's suggested operating procedures

(4) condition of the load required for operation of the lifter, such as, but not limited to, balance, surface cleanliness, flatness, bending, and load thickness

(5) storage of the lifter to protect it from damage

(6) not exceeding the rated load of the lifting device nor the capacity of the hoisting equipment by the combined weight of the load, the lifting device, and rigging

(7) charging of the lifting magnet battery (if required)

(8) the purpose of indicators, meters, or alarms on the lifting magnet

(9) the proper attachment of adapters to lifting device for special load handling

(b) The operator shall demonstrate the ability to operate the lifter as instructed before assuming responsibility for using the lifter.

(c) The operator shall demonstrate an understanding of standard hand signals when applicable.

20-3.4.3 Responsibilities

While the organizational structure of various projects may differ, the following roles are described here for purposes of delineating responsibilities. All responsibilities listed below shall be assigned in the worksite organization. (A single individual may perform one or more of these roles.)

operator: directly controls the lifting device's functions.

owner: has custodial control of a lifting device by virtue of lease or ownership.

These persons and roles may or may not match the persons and roles associated with the hoisting equipment in use.



Responsibilities of the Lifting Device

responsibilities of the lifting device owner shall include the following:

(a) providing a lifting device, and all necessary components specified by the manufacturer, that meets the requirements of Sections 20-3.2 and 20-3.3 as well as specific job requirements.

(b) providing all applicable operating instructions.

(c) providing field assembly, and disassembly (if applicable), operation and maintenance information, and warning decals and placards installed as prescribed by the lifting device manufacturer.

(d) establishing an inspection, testing, and maintenance program in accordance with Section 20-3.3.

(e) using designated personnel to perform the required maintenance, repair, and inspections.

(f) ensuring that the lifting device is in proper operating condition prior to initial use at the worksite by the following:

(1) verifying that all inspections have been performed as required by Section 20-3.3

(2) verifying that the lifting device has the necessary lifting capacity to perform the proposed lifting operations in the planned configuration

(g) using operators that meet the requirements of para. 20-3.4.2.

(h) ensuring that all personnel involved in maintenance, repair, assembly, disassembly, and inspection are aware of their responsibilities, assigned duties, and the associated hazards.

(i) determining if additional regulations are applicable to lifting device operations.

(j) ensuring that conditions that may adversely affect lifting device operations are addressed. Such conditions include, but are not limited to, the following:

(1) wind velocity or gusting winds

(2) precipitation

(3) fog

(4) extreme temperatures

(5) lighting

(k) addressing safety concerns raised by the operator or other personnel and being responsible if he and a qualified person decide to overrule those concerns and direct lifting device operations to continue. (In all cases, the manufacturer's criteria for safe operation and the requirements of this Volume shall be followed.)

- (18) **20-3.4.3.2 Responsibilities of Operators.** The operator shall be responsible for the following listed items. The operator shall not be responsible for hazards or conditions that are not under his direct control and that adversely affect operation of the lifting device. Whenever the operator has doubt as to the safety of lifting device operations, the operator shall place the load in a safe condition and stop the lifting device's functions in a controlled manner. Use of the lifting device shall resume only after safety concerns

have been addressed or the continuation of lifting device operations is directed by the owner.

The operator's responsibilities shall include the following:

(a) reviewing the requirements for the lifting device with the owner before operations.

(b) knowing what types of site conditions could adversely affect the operation of the lifting device and consulting with the owner concerning the possible presence of those conditions.

(c) understanding and applying the information contained in the lifting device manufacturer's operating manual.

(d) understanding the lifting device's functions and limitations as well as its particular operating characteristics.

(e) ensuring an inspection is performed prior to every lift as specified in para. 20-3.3.2.

(f) promptly reporting the need for any adjustments or repairs to a designated person.

(g) following applicable lock out/tag out procedures.

(h) not operating the lifting device when physically or mentally unfit.

(i) ensuring that all controls are in the off or neutral position and that all personnel are in the clear before attaching the lifting device.

(j) not engaging in any practice that will divert his attention while operating the lifting device.

(k) testing the lifting device function controls that will be used and operating the lifting device only if those function controls respond properly.

(l) operating the lifting device's functions, under normal operating conditions, in a smooth and controlled manner.

(m) knowing and following the procedures specified by the manufacturer or approved by a qualified person, for assembly, disassembly, setting up, and reeving/rigging of the lifting device.

(n) considering all factors known that might affect the lifting device capacity and informing the owner of the need to make appropriate adjustments.

(o) understanding basic load attachment procedures.

(p) responding only to instructions from designated persons. However, the operator shall obey a stop order at all times, no matter who gives it.

(q) ensuring that all personnel shall stay clear of the load.

(r) not lifting stacked loads with a permanent magnet unless approved by the manufacturer.

20-3.4.4 Lifting Device Operating Practices

(18)

(a) *All Magnets*

(1) Lifting devices shall be operated only by the following qualified personnel:

(-a) designated persons



trainees under the supervision of a designated person. The number of trainees permitted to be supervised by a single designated person, the physical location of the designated person while supervising, and the type of communication required between the designated person and the trainee shall be determined by a qualified person

(-c) maintenance and test personnel, when it is necessary in the performance of their duties

(-d) inspectors (lifting devices)

(2) Ensure the weight of the load and its approximate center of gravity have been obtained, provided, or calculated.

(3) The lifting device shall not be loaded in excess of its rated load or handle any load for which it is not designed.

(4) Properly attaching the lifting device to the hook, shackle, or other load handling device.

(5) The lifter shall be applied to the load in accordance with the instruction manual.

(6) Before lifting, the operator shall make sure that lifter ropes or chains are not kinked and that multiple part lines are not twisted around each other.

(7) Verify that the load is well secured and properly balanced in the lifting device when it is initially lifted.

(8) Care should be taken to make certain the load is correctly distributed for the lifter being used.

(9) The temperature of the load should not exceed the maximum allowable limits of the lifter.

(10) Do not allow the load or lifter to come into contact with any obstruction.

(11) The operator shall ensure that the lifting device is adequately protected from damage during use.

(12) The lifter shall not be used for side pulls or sliding the load unless specifically authorized by a qualified person.

(13) The lifting magnet face and the lifting magnet contact area on the load shall be clean.

(14) The load to be lifted shall be within the lifting magnet's rated load (capacity) or application load (capacity) and lifting equipment rated load (capacity).

(15) The operator shall observe all meters and indicators on the lifting magnet to confirm proper operation prior to making a lift.

(16) Before raising the load more than 2 in. (50 mm), any adjustable input control should be switched to the "full power" or "full on" position and remain in this position until the load is removed from the lifting magnet.

(-a) Before lifting, the operator shall warn people near the lift.

(-b) The operator shall not switch the magnet to the "attach" position until the lifting magnet has been placed in contact with the load to be lifted. Prematurely switching the magnet to the "attach" position could cause unwanted materials to be attracted to the lifting magnet.

(-c) The operator shall land any attached load and release the load before leaving the lifting device. The operator shall not leave suspended loads unattended.

(-d) The operator shall not ride, or allow others to ride loads or the lifting device.

(-e) The operation of the lifter shall be observed during use. Any deficiency observed shall be examined by a designated person. If the deficiency constitutes a hazard, the lifter shall be removed from service and tagged "Out of Service." Any indication of a hazardous condition shall be reported to a qualified person for evaluation.

(-f) Loads shall be guided in such a manner as to avoid endangering hands or other body parts as the load is moved, or if it drops.

(-g) When lifting loads that do not absorb all available flux, use caution to avoid lifting multiple loads.

(b) Battery Operated Electromagnets

(1) Before lifting, the operator should confirm that the device indicating correct current flow remains stable for a minimum of 5 sec.

(2) For a lift of extended duration, the operator should observe the device indicating existing battery conditions every 5 min.

(3) The operator should open the ventilation lid before charging the battery.

(c) *Electrically Controlled Permanent Magnets.* Before lifting, the operator should check the internal control function indicator, where applicable, to confirm proper operation of the lifting magnet.

(d) *Manually Controlled Permanent Magnets.* Before lifting, the operator should confirm that the control handle is in the "attach" position and the control handle latch is operating.

(e) Battery Charging of Battery Operated Electromagnets or Battery Backup Systems

(1) Vented wet cell batteries shall be recharged at the first indication of current flow or voltage below the manufacturer's recommended range.

(2) Vented wet cell batteries shall be charged (-a) in a well-ventilated area to avoid accumulation of combustible gases

(-b) where personnel are least likely to be exposed to vented fumes or electrolyte spillage

(3) All batteries shall be charged prior to being returned to service according to the recommendations supplied by the lifting magnet manufacturer.

(4) Eye, hand, and body protection shall be worn while servicing batteries.

20-3.4.5 Miscellaneous Operating Practices

(a) An operator shall not use a lifting device that is tagged "Out of Service" or otherwise designated as nonfunctioning.



Service” tags on lifting devices shall not be without the approval of the person placing them. The person placing them shall be a qualified person.

(c) The lifter, when not in use, should be stored at an assigned location.

(d) Caution should be taken that operating markings or tags shall not be removed or defaced. Missing or illegible markings or tags shall be replaced.

(18) SECTION 20-3.5: INSTRUCTION MANUALS

The manufacturer shall provide operating instructions, safety precautions, and maintenance information. In addition, the manual shall also provide a statement of those factors that alter the magnet’s lifting capacity and related limitations. Several factors known to affect that magnet’s lifting capacity are noted below.

(a) *Load Thickness.* The magnetic flux flowing from a lifting magnet into a load increases as the thickness of the load increases. Consequently, as a lifting magnet’s lifting capacity is a function of this flux, the lift capacity increases with load thickness. For every lifting magnet design, there is a critical load thickness where all of the lifting magnet’s available flux flows into the load and the lift capacity reaches maximum. Loads thicker than the critical load thickness will not increase the magnet lift capacity beyond this level. As loads become thinner than the critical load thickness, the magnet’s lift capacity diminishes since the load cannot transmit all the flux generated by the magnet.

(b) *Load Alloy.* Many alloys of iron do not accept magnetic flux as easily as do low carbon steels. Consequently, loads of such alloys will not accept all of

the flux available in the lifting magnet, which reduces the lifting magnet’s lift capacity.

(c) *Load Surface Conditions.* Anything that creates an air gap or nonmagnetic separation between a lifting magnet and the load reduces the flux flowing from the lifting magnet into the load, which reduces the lifting capacity of a lifting magnet. Typical causes of air gaps are: rough surface finish, paper, dirt, rust, paint, and scale.

(d) *Load Length or Width.* As the length or width of the load increases, the load begins to deflect and to peel at the lifting magnet face. This may create an air gap between the load and the lifting magnet, which reduces the lifting capacity per (c). The manual shall contain manufacturer’s recommendations pertaining to the maximum load dimensions.

(e) *Attitude of Load.* As the attitude of the surface of the load to which a lifting magnet is attached (lifting surface) changes from horizontal to vertical, the lifting capacity of the lifting magnet is greatly reduced and becomes dependent upon the coefficient of friction of the lifting surface.

(f) *Portion of Lifting Magnet Face in Contact With Load.* The full face of the lifting magnet must contact the load if the lifting magnet is to achieve maximum capabilities.

(g) *Load Temperature.* The temperature of the load can cause damage to the lifting magnet and, if high enough, even change the magnetic characteristics of the load. Consequently, the manual shall contain the manufacturer’s recommendations pertaining to operation of the lifting magnet on loads at temperatures exceeding normal ambient temperatures.

آریا ایمن آوات

Chapter 20-4 Remotely Operated Lifting Magnets

SECTION 20-4.1: SCOPE

Chapter 20-4 applies to the marking, construction, installation, inspection, testing, maintenance, and operation of remotely operated lifting magnets (see Figure 20-4.1-1). This Chapter applies to remotely operated lifting magnets in areas where people are excluded during normal operation. This Chapter does not apply to close proximity operated magnets.

SECTION 20-4.2: MARKING, CONSTRUCTION, AND INSTALLATION

(18) 20-4.2.1 Marking

(a) Rated Load

(1) *General Application Lifting Magnets.* The rated load of the lifting magnet shall be legibly marked on the lifting magnet or on a tag attached to the lifting magnet where it is visible. This marking shall refer to the instruction manual for information relating to

decreases in rating due to the load surface condition, thickness, percentage of contact with the lifting magnet, temperature, metallurgical composition, and deflection.

(2) *Specified Application Lifting Magnets.* The rated load of the lifting magnet shall be legibly marked on the lifting magnet or on a tag attached to the lifting magnet where it is visible. This marking shall describe the specific loads for which this rating applies.

(b) *Identification.* Remotely operated lifting magnets shall be provided with identification displaying, but not limited to, the following information:

- (1) manufacturer's name and contact information
- (2) serial number (unique unit identifier)
- (3) weight of lifting magnet
- (4) duty cycle (when applicable)
- (5) the cold current (amps) at 68°F (20°C) (when applicable)
- (6) the voltage of the primary power supply or battery (when applicable)
- (7) rated load [see (a)]

(18)

Figure 20-4.1-1 Remotely Operated Magnetic Lifters

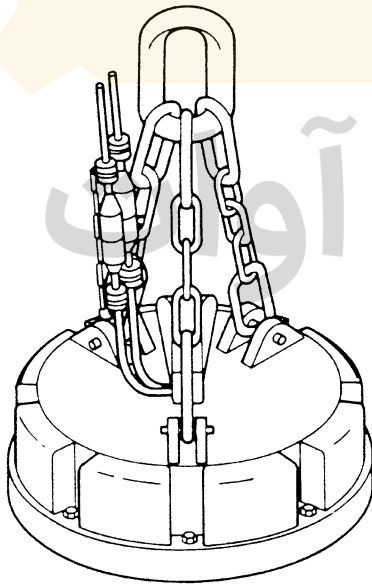

(a) Remotely Operated Lifting Electromagnet — Circular

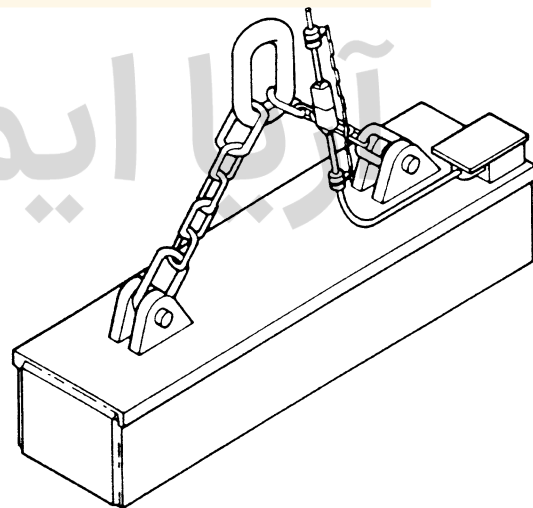

(b) Remotely Operated Lifting Electromagnet — Rectangular



ASME BTH-1 Design Category B
ASME BTH-1 Service Class

Repaired or Altered Lifting Magnets. Repaired or altered magnets shall be provided with identification displaying, but not limited to, the following information:

- (1) name and contact information of the repairer or alterer
- (2) repairer's or alterer's unit identification
- (3) weight of lifting magnet (if altered)
- (4) duty cycle (if altered)
- (5) the cold current or wattage at 68°F (20°C) (if altered)
- (6) the voltage of the primary power supply or battery (if altered)
- (7) rated load [see (a)]
- (8) ASME BTH-1 Design Category B
- (9) ASME BTH-1 Service Class (if altered)

This requirement is not applicable to repairs limited to replacement of maintenance parts.

(d) Product Safety Labels

(1) Where size and shape of the lifter allow, lifters shall have labels affixed to them in a readable position, that include the appropriate signal word, according to ANSI Z535.4-2011, to bring the label to the attention of the operator. The label should include cautionary language identifying hazards, methods for accident prevention, and refer to instruction manuals for additional information.

(2) Where size or shape of lifting magnet prohibits the inclusion of all or any such markings, a label shall be affixed, referring user to consult manufacturer's instruction manual for product safety information.

(3) Labels on battery operated lifting magnets shall provide additional cautionary language about operating when the battery capacity is inadequate.

(4) Labels on externally powered electromagnets shall contain additional cautionary language against

(-a) exceeding lifting magnet duty cycle

(-b) disconnecting lifting magnet with power on

(e) *Operating Controls*. Each control shall be clearly marked describing resulting motion or function of the lifter.

(18) **20-4.2.2 Construction**

(a) General

(1) *Suspension Devices*. Lifting magnet suspension devices should meet the lifting magnet manufacturer's recommendations.

(2) *Lifter Design*. The manufacturer shall verify that remotely operated lifting magnets are in accordance with ASME BTH-1. Remotely operated lifting magnets shall be designed to ASME BTH-1, Design Category B (static strength criteria), and the proper Service Class (fatigue life criteria) selected for its number of load cycles.

(3) *Welding*. Welding shall be in accordance with ASME BTH-1, para. 1-4.6.

(b) *Electrical Equipment*. External power supply, electrical equipment, and wiring for electromagnets shall be in accordance with ASME BTH-1.

(c) *Lifting Magnet Controllers*. Lifting magnet controllers should have voltage and amperage indicated (when applicable).

(d) *Power Disconnects*. Disconnects are not required on externally powered electromagnets operating from a 120 VAC single-phase power source.

(e) *Alterations*. Lifting magnets may be altered or repaired, provided such alterations and the supporting structure are analyzed and approved by the lifting magnet manufacturer or a qualified person. A repaired lifting magnet or one whose load-bearing structural components have been altered shall conform to (a)(3) and be tested in accordance with para. 20-4.3.7.

(f) *Slings*. When employed, slings shall meet the requirements of ASME B30.9.

(g) *Hooks*. When employed, hooks shall meet the requirements of ASME B30.10.

(h) *Rigging Hardware*. When employed, rigging hardware shall meet the requirements of ASME B30.26.

20-4.2.3 Installation

(a) The lifting magnet shall be installed in accordance with the manufacturer's instructions.

(b) Determine that the external power input is in accordance with paras. 20-4.2.2(b) and 20-4.2.2(d), is of the correct voltage and amperage, and that the power conductors and controls are of adequate rating, and insulated and protected against accidental interruption or damage.

SECTION 20-4.3: INSPECTION, TESTING, AND MAINTENANCE

20-4.3.1 Inspection Classification

(18)

General. All inspections shall be performed by a designated person. Any deficiencies identified shall be examined and a determination made by a qualified person as to whether they constitute a hazard, and if so, what additional steps need to be taken to address the hazard.

Inspection of slings (ASME B30.9), hooks (ASME B30.10), rigging hardware (ASME B30.26), or other special devices shall comply with the inspection requirements in the applicable volume.

(a) Initial Inspection

(1) New and reinstalled lifting magnets shall be inspected prior to initial use to verify compliance with applicable provisions of this Volume.

(2) Altered or repaired lifting magnets shall be inspected. The inspection may be limited to the components affected by the alteration or repair, as determined by a qualified person.



pection Intervals. Inspection procedures for magnets in regular service are divided into two general classifications, based upon the intervals at which the inspections shall be performed. The intervals, in turn, are dependent upon the nature of the critical components of the lifting magnet and the degree of their exposure to wear, deterioration, or malfunction. The two general classifications are designated as *frequent* and *periodic*, with respective intervals between inspections as defined below.

(1) *Frequent Inspection.* Visual examination by the operator or other designated persons with records not required.

(-a) Normal service — monthly

(-b) Heavy service — weekly to monthly

(-c) Severe service — daily to weekly

(-d) Special or infrequent service — as recommended by a qualified person before and after each lift

(2) *Periodic Inspection.* Visual inspection making records of apparent external conditions to provide the basis for a continuing evaluation.

(-a) Normal service for equipment in place — yearly

(-b) Heavy service for equipment in place — quarterly

(-c) Severe service — monthly

(-d) Special or infrequent service — as recommended by a qualified person before the first lift and as directed by the qualified person for any subsequent lifts

(18) 20-4.3.2 Frequent Inspection

Items such as the following shall be inspected for damage at intervals as defined in para. 20-4.3.1(b)(1), including observations during operation for any indications of damage that might appear between inspections. A qualified person shall determine whether any indications of damage constitute a hazard or will require more frequent inspection. For all lifting magnets, inspect

(a) structural and suspension members for deformation, cracks, or excessive wear on any part of the lifting magnet

(b) lifting magnet face for foreign materials and smoothness, if applicable

(c) all electrical conductors that are visible without disassembly

(d) cracked housings, welds, and loose bolts

(e) missing or illegible operating control markings

(f) for battery operated electromagnets, inspect for proper level of battery electrolyte and for corrosion of either the battery posts or connectors

(18) 20-4.3.3 Periodic Inspection

Complete inspections of lifting magnets shall be performed and recorded at intervals as defined in para. 20-4.3.1(b)(2). Any deficiencies, such as those listed below, shall be examined by a qualified person

and determination made as to whether they constitute a hazard. These inspections shall include the requirements of para. 20-4.3.2 and, in addition, items such as the following:

(a) All members, fasteners, and lifting parts shall be inspected for deformation, wear, and corrosion.

(b) All electrical components described in para. 20-4.2.2, including meters, indicators, or alarms, shall be tested for proper operation and condition.

(c) The lifting magnet coil shall be tested for ohmic and ground readings, and compared to manufacturer's standards.

(d) Missing or illegible product safety labels required by para. 20-4.2.1(d).

20-4.3.4 Lifting Magnets Not in Regular Use

A lifting magnet that has been idle for a period of 1 month to 1 yr shall be inspected in accordance with para. 20-4.3.2 before being placed in service. A lifting magnet that has been idle for a period of 1 yr or more shall be inspected in accordance with para. 20-4.3.3 before being returned to service.

20-4.3.5 Inspection Records

Dated inspection reports shall be made on critical items, such as those listed in para. 20-4.3.3. Records should be available for each periodic inspection and when the lifting magnet is either altered or repaired.

20-4.3.6 Repairs

(18)

Damage disclosed by the inspection requirements of Section 20-4.3 shall be corrected according to the procedures outlined in para. 20-4.3.8 before operation of the lifting magnet is resumed, unless a qualified person determines the damage does not constitute a hazard. Repairs of slings (ASME B30.9), hooks (ASME B30.10), rigging hardware (ASME B30.26), or other special devices shall comply with repair requirements in the applicable volumes or standards.

20-4.3.7 Testing

(18)

20-4.3.7.1 Operational Tests

(a) New and reinstalled lifting magnets shall be tested by a qualified person, or a designated person under the direction of the manufacturer or a qualified person, prior to initial use to verify compliance with applicable provisions of this Volume, including, but not limited to, the following:

(1) moving parts

(2) latches

(3) stops

(4) switches

(5) any control devices

(6) alarms



ator lights, gages, horns, bells, alarms, pointer warning devices

Altered or repaired lifting magnets shall be tested by a qualified person, or a designated person under the direction of the manufacturer or a qualified person. The test may be limited to the components affected by the alteration or repair, as determined by a qualified person with guidance from the manufacturer.

(c) Dated reports of all operational test shall be filed.

20-4.3.7.2 Load Test

(a) Prior to initial use, all new, altered, or repaired lifting magnets shall be tested by a qualified person, or a designated person under the direction of the manufacturer or a qualified person. The rated load for all components associated with the magnet shall meet the maximum breakaway force of the magnet to avoid overload or the components shall not be included in the test. The test results shall be recorded confirming the load rating of the lifting magnet.

(1) Breakaway Force Test

(-a) General application lifting magnets shall be required to satisfy the general application lifting magnet breakaway force test.

(-1) The rated load for permanent magnet lifters shall be less than 33% of the breakaway force measured in this test.

(-2) The rated load for electromagnet lifters shall be less than 50% of the breakaway force measured in this test.

(-b) Specified application lifting magnets shall be required to satisfy the specified application lifting magnet breakaway force test.

(-1) The rated load for permanent magnet lifters shall be less than 33% of the breakaway force measured in this test.

(-2) The rated load for electromagnet lifters shall be less than 50% of the breakaway force measured in this test.

(2) *Design Factor Test.* Remote operated lifting magnets should have an annual magnetic design factor test to verify the magnet meets (1)(-a) or (1)(-b). This test should be performed to the actual breakaway point of the magnet or may be performed at the calculated minimum breakaway force. The rated load of lifting hardware associated with the magnetic design factor test shall exceed the maximum breakaway load of the magnet to avoid overload or the lifting hardware shall be removed. Caution should be applied during the test. The test shall be performed under the direction of a qualified person.

(b) The general application lifting magnet breakaway force test shall establish the force required to vertically remove the lifting magnet from a low carbon, rolled steel plate of the minimum thickness stated by the lifting magnet manufacturer. The portion of this plate that is

in contact with the lifting magnet shall have a surface finish of 125 $\mu\text{in.}$ (3.2×10^{-3} mm) or better and be flat within 0.002 in./ft (0.05 mm/30 cm), without exceeding 0.005 in. (0.127 mm) total. The full operating face of the lifting magnet shall be in contact with the steel plate, which shall be between 60°F (15°C) and 120°F (50°C). The steel plate, load cell or other testing device shall be mounted to allow self-alignment so the load is applied to the magnet through the magnet's center of force.

(c) The specified application lifting magnet breakaway force test shall establish the breakaway forces of the lifting magnet under the variety of loading conditions for which the lifting magnet is specified. The details of this test should be supplied by the manufacturer of the lifting magnet.

(d) Battery operated electromagnets and externally powered electromagnets shall be operated at the manufacturer's recommended voltage and current levels.

(e) The test for altered or repaired lifting magnets may be limited to the components affected by the alteration or repair, as determined by a qualified person with guidance from the manufacturer.

20-4.3.8 Maintenance

(18)

(a) *Maintenance Program.* A maintenance program shall be established and be based on recommendations made by the lifting magnet manufacturer. If a qualified person determines it is appropriate, the program should also include that individual's additional recommendations based on a review of the lifting magnet application and operations.

(b) Maintenance Procedure

(1) Before adjustments and repairs are started on a lifting magnet or its controls, the following precautions shall be taken:

(-a) All sources of lifting magnet power shall be disconnected, locked out, and tagged "Out of Service."

(-b) A lifting magnet removed from service for repair shall be tagged "Out of Service."

(-c) Relieve fluid pressure from all circuits before loosening or removing fluid power components.

(2) Only designated personnel shall work on equipment when maintenance, repairs, and tests are required.

(3) Replacement parts shall be at least equal to the original manufacturer's specifications.

(4) After adjustments and repairs have been made, the lifting magnet shall not be returned to service until it has been inspected according to para. 20-4.3.3.

(5) Dated records of repairs and replacements should be made.



20-4.4: OPERATION

4.1 Operators

Below-the-hook lifting devices shall be operated only by trained, designated persons.

(18) 20-4.4.2 Qualifications

Qualifications for operators of below-the-hook lifting devices are as follows:

(a) The operator shall be instructed in the use of the device by a designated person before operating the device. Instructions should include, but not be limited to, the following:

(1) application of the lifter to the load and material-handling device, and adjustments, if any, that adapt the lifter to various sizes or kinds of loads

(2) instructions in any special operations or precautions

(3) the manufacturer's suggested operating procedures

(4) condition of the load required for operation of the lifter, such as, but not limited to, balance, surface cleanliness, flatness, bending, and load thickness

(5) storage of the lifter to protect it from damage

(6) not exceeding the rated load of the lifting device nor the capacity of the hoisting equipment by the combined weight of the load, the lifting device, and rigging

(7) charging of the lifting magnet battery (if required)

(8) the purpose of indicators, meters, or alarms on the lifting magnet

(9) the proper attachment of adapters to lifting device for special load handling

(b) The operator shall demonstrate the ability to operate the lifter as instructed before assuming responsibility for using the lifter.

(c) The operator shall demonstrate an understanding of standard hand signals when applicable.

20-4.4.3 Responsibilities

While the organizational structure of various projects may differ, the following roles are described here for purposes of delineating responsibilities. All responsibilities listed below shall be assigned in the worksite organization. (A single individual may perform one or more of these roles.)

operator: directly controls the lifting device's functions.

owner: has custodial control of a lifting device by virtue of lease or ownership.

These persons and roles may or may not match the persons and roles associated with the hoisting equipment in use.

20-4.4.3.1 Responsibilities of the Lifting Device Owner. The responsibilities of the lifting device owner shall include the following: (18)

(a) providing a lifting device, and all necessary components specified by the manufacturer, that meets the requirements of Sections 20-4.2 and 20-4.3 as well as specific job requirements.

(b) providing all applicable operating instructions.

(c) providing field assembly, and disassembly (if applicable), operation and maintenance information, and warning decals and placards installed as prescribed by the lifting device manufacturer.

(d) establishing an inspection, testing, and maintenance program in accordance with Section 20-4.3.

(e) using designated personnel to perform the required maintenance, repair, and inspections.

(f) ensuring that the lifting device is in proper operating condition prior to initial use at the worksite by the following:

(1) verifying that all inspections have been performed as required by Section 20-4.3

(2) verifying that the lifting device has the necessary lifting capacity to perform the proposed lifting operations in the planned configuration

(g) using operators that meet the requirements of para. 20-4.4.2.

(h) ensuring that all personnel involved in maintenance, repair, assembly, disassembly, and inspection are aware of their responsibilities, assigned duties, and the associated hazards.

(i) determining if additional regulations are applicable to lifting device operations.

(j) ensuring that conditions that may adversely affect lifting device operations are addressed. Such conditions include, but are not limited to, the following:

(1) wind velocity or gusting winds

(2) precipitation

(3) fog

(4) extreme temperatures

(5) lighting

(k) addressing safety concerns raised by the operator or other personnel and being responsible if he and a qualified person decide to overrule those concerns and directs lifting device operations to continue. (In all cases, the manufacturer's criteria for safe operation and the requirements of this Volume shall be followed.)

20-4.4.3.2 Responsibilities of Operators. The operator shall be responsible for the following listed items. The operator shall not be responsible for hazards or conditions that are not under his direct control and that adversely affect operation of the lifting device. Whenever the operator has doubt as to the safety of lifting device operations, the operator shall place the load in a safe condition and stop the lifting device's functions in a controlled manner. Use of the lifting device shall resume only after safety concerns (18)



pressed or the continuation of lifting device operation directed by the owner.

The operator's responsibilities shall include the following:

(a) reviewing the requirements for the lifting device with the owner before operations.

(b) knowing what types of site conditions could adversely affect the operation of the lifting device and consulting with the owner concerning the possible presence of those conditions.

(c) understanding and applying the information contained in the lifting device manufacturer's operating manual.

(d) understanding the lifting device's functions and limitations as well as its particular operating characteristics.

(e) performing a Frequent Inspection as specified in para. 20-4.3.2.

(f) promptly reporting the need for any adjustments or repairs to a designated person.

(g) following applicable lock out/tag out procedures.

(h) not operating the lifting device when physically or mentally unfit.

(i) ensuring that all controls are in the off or neutral position and that all personnel are in the clear before attaching the lifting device.

(j) not engaging in any practice that will divert his attention while operating the lifting device.

(k) testing the lifting device function controls that will be used and operating the lifting device only if those function controls respond properly.

(l) operating the lifting device's functions, under normal operating conditions, in a smooth and controlled manner.

(m) knowing and following the procedures specified by the manufacturer or approved by a qualified person, for assembly, disassembly, setting up, and reeving/rigging of the lifting device.

(n) considering all factors known that might affect the lifting device capacity and informing the owner of the need to make appropriate adjustments.

(o) understanding basic load attachment procedures.

(p) responding only to instructions from designated persons. However, the operator shall obey a stop order at all times, no matter who gives it.

(q) ensuring that all personnel shall stay clear of the load.

(r) not lifting stacked loads with a permanent magnet unless approved by the manufacturer.

(18) 20-4.4.4 Lifting Device Operating Practices

(a) Lifting devices shall be operated only by the following personnel:

(1) designated persons

(2) trainees under the supervision of a designated person, the number of trainees permitted to be supervised by a single designated person, the physical location of the designated person while supervising, and the type of communication required between the designated person and the trainee shall be determined by a qualified person

(3) maintenance and test personnel, when it is necessary in the performance of their duties

(4) inspectors (lifting devices)

(b) Ensure the weight of the load and its approximate center of gravity have been obtained, provided, or calculated.

(c) The lifting device shall not be loaded in excess of its rated load or handle any load for which it is not designed.

(d) Properly attaching the lifting device to the hook, shackle, or other load handling device.

(e) The lifter shall be applied to the load in accordance with the instruction manual.

(f) Before lifting, the operator shall make sure that lifter ropes or chains are not kinked and that multiple part lines are not twisted around each other.

(g) Verify that the load is well secured and properly balanced in the lifting device when it is initially lifted.

(h) Care should be taken to make certain the load is correctly distributed for the lifter being used.

(i) The temperature of the load should not exceed the maximum allowable limits of the lifter.

(j) Do not allow load or lifter to come into contact with any obstruction.

(k) The operator shall ensure that the lifting device is adequately protected from damage during use.

(l) The lifter shall not be used for side pulls or sliding the load unless specifically authorized by a qualified person.

(m) The operator shall land any attached load and store the lifter before leaving the lifting device. The operator shall not leave suspended loads unattended.

(n) The operator shall not ride, or allow others to ride loads or the lifting magnet.

(o) The operation of the lifter shall be observed during use. Any deficiency observed shall be examined by a designated person. If the deficiency constitutes a hazard, the lifter shall be removed from service and tagged "Out of Service." Any indication of a hazardous condition shall be reported to a qualified person for evaluation.

(p) When lifting loads that do not absorb all available flux, use caution to avoid lifting multiple loads.

20-4.4.5 Miscellaneous Operating Practices

(a) An operator shall not use a lifting device that is tagged "Out of Service" or otherwise designated as nonfunctioning.

(b) "Out of Service" tags on lifting devices shall not be removed without the approval of the person placing them or a designated person.



lifter, when not in use, should be stored at an appropriate location.

Caution should be taken that operating markings or tags shall not be removed or defaced. Missing or illegible markings or tags shall be replaced.

(18) SECTION 20-4.5: INSTRUCTION MANUALS

The manufacturer shall provide operating instructions, safety precautions, and maintenance information. In addition, the manual shall also provide a statement of those factors that alter the lifting magnet's lifting capacity and related limitations. Several key factors known to affect the magnet's lifting capacity are noted below.

(a) *Load Thickness.* For every lifting magnet design, there is a critical load thickness where all of the lifting magnet's available flux flows into the load and the magnet's lift capacity reaches maximum. Loads thicker than the critical load thickness will not increase the magnet lift capacity beyond this level. As loads become thinner than the critical load thickness, the magnet's lift capacity diminishes since the load cannot transmit all the flux generated by the magnet.

(b) *Load Alloy.* Many alloys of iron do not accept magnetic flux as easily as do low carbon steels. Consequently, loads of such alloys will not accept all of the flux available in the lifting magnet, which reduces the lifting magnet's lift capacity.

(c) *Load Surface Conditions.* Anything that creates an air gap or nonmagnetic separation between a lifting magnet and the load reduces the flux flowing from the lifting magnet into the load, which reduces the lifting capacity of a lifting magnet. Typical causes of air gaps are: rough surface finish, paper, dirt, rust, paint, and scale.

(d) *Load Length or Width.* As the length or width of the load increases, the load begins to deflect and to peel at the lifting magnet face. This may create an air gap between the load and the lifting magnet, which reduces the lifting capacity per (c). The manual shall contain manufacturer's recommendations pertaining to the maximum load dimensions for a particular lifting magnet.

(e) *Attitude of Load.* As the attitude of the surface of the load to which a lifting magnet is attached (lifting surface) changes from horizontal to vertical, the lifting capacity of the lifting magnet is greatly reduced and becomes dependent upon the coefficient of friction of the lifting surface.

(f) *Portion of Lifting Magnet Face in Contact With Load.* The full face of the lifting magnet must contact the load if the lifting magnet is to achieve maximum capabilities.

(g) *Load Temperature.* The temperature of the load can cause damage to the lifting magnet and, if high enough, even change the magnetic characteristics of the load. Consequently, the manual shall contain the manufacturer's recommendations pertaining to operation of the lifting magnet on loads at temperatures exceeding normal ambient temperatures.

آریا ایمن آوات

Chapter 20-5 Scrap and Material-Handling Grapples

SECTION 20-5.1: SCOPE

Chapter 20-5 applies to the marking, construction, installation, inspection, testing, maintenance, and operation of hydraulically operated scrap and material-handling grapples (see Figure 20-5.1-1).

SECTION 20-5.2: MARKING, CONSTRUCTION, AND INSTALLATION

(18) 20-5.2.1 Marking

(a) *Identification.* Scrap and material-handling grapples shall be marked with, but not limited to, the following information:

- (1) manufacturer's name and contact information
- (2) serial number (unique unit identifier)
- (3) grapple weight
- (4) rated voltage (when applicable)
- (5) operating hydraulic pressure(s)
- (6) rated load
- (7) ASME BTH-1 Design Category B
- (8) ASME BTH-1 Service Class

(b) *Repaired or Altered Grapples.* Repaired or altered scrap and material-handling grapples shall be provided with identification displaying, but not limited to, the following information:

- (1) name and contact information of the repairer or alterer
- (2) repairer's or alterer's unit identification
- (3) grapple weight (if altered)
- (4) operating hydraulic pressure(s) (if altered)
- (5) rated voltage (if altered)
- (6) rated load (if altered)
- (7) ASME BTH-1 Design Category B
- (8) ASME BTH-1 Service Class (if altered)

This requirement is not applicable to repairs limited to replacement of maintenance parts.

(c) *Operating Controls.* Each control shall be clearly marked describing resulting motion or function of the lifter (if altered).

(18) 20-5.2.2 Construction

(a) *General.* The manufacturer shall verify that scrap and material-handling grapples are designed by or under the supervision of a qualified person. The design shall be in accordance with ASME BTH-1.

Scrap and material-handling grapples shall be designed to ASME BTH-1 Design Category B (static strength criteria) and the proper Service Class (fatigue life criteria) selected for the number of load cycles.

(b) *Welding.* Welding shall be in accordance with ASME BTH-1, para. 1-4.6.

(c) *Electrical Equipment.* External power supply, electrical equipment, and wiring for below-the-hook lifters shall be in accordance with ASME BTH-1.

(d) *Grapple Magnets.* Lifting magnet construction shall comply with para. 20-4.2.2.

(e) *Alterations.* Grapples may be altered or rerated, provided such modifications are analyzed and approved by the equipment manufacturer or a qualified person. A rerated grapple or one whose components have been altered shall be tested according to para. 20-5.3.7. New rated capacity shall be displayed in accordance with para. 20-5.2.1(b).

(f) *Slings.* When employed, slings shall meet the requirements of ASME B30.9.

(g) *Hooks.* When employed, hooks shall meet the requirements of ASME B30.10.

(h) *Rigging Hardware.* When employed, rigging hardware shall meet the requirements of ASME B30.26.

20-5.2.3 Installation

(a) The grapple shall be installed in accordance with the manufacturer's instructions.

(b) The user shall confirm that the hydraulic flows and pressures are the same as indicated on the grapple nameplate.

(c) Determine that the external power input is in accordance with para. 20-5.2.2(c), and is of the correct voltage and amperage.

(d) Confirm that the electrical power conductors and controls are of adequate rating, and insulated and protected against inadvertent interruption or damage.

SECTION 20-5.3: INSPECTION, TESTING, AND MAINTENANCE

20-5.3.1 Inspection Classification

(18)

General. All inspections shall be performed by a designated person. Any deficiencies identified shall be examined and a determination made by a qualified person as to

Figure 20-5.1-1 Scrap and Material-Handling Grapples

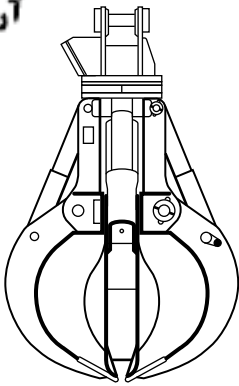

(a) Four-Tine Orange Peel Grapple

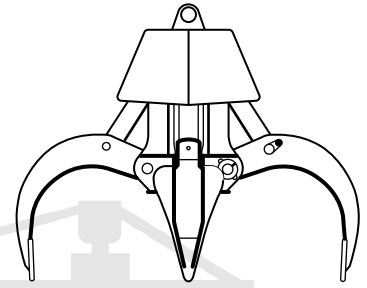
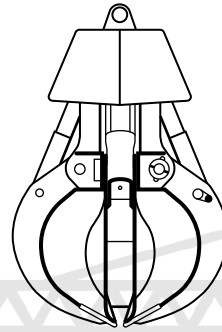
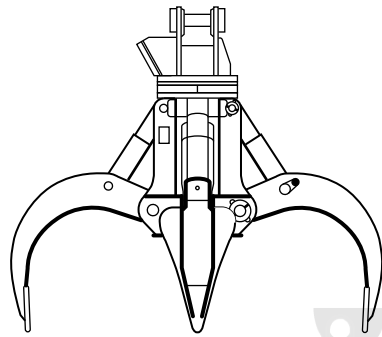

(b) Electrohydraulic Grapple

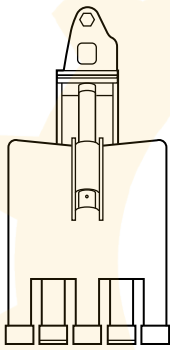

(c) Three-in-One Grapple

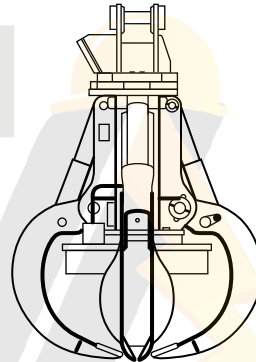
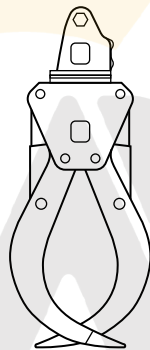

(d) Magnet Grapple

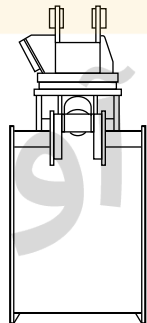
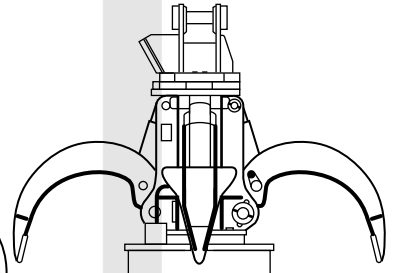

(e) Car Body Grapple

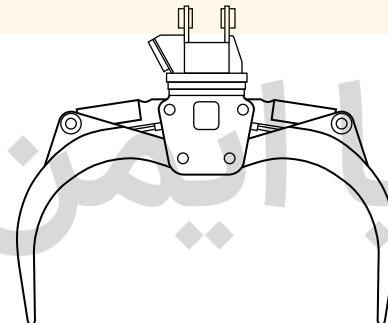



constitute a hazard, and if so, what addition need to be taken to address the hazard. of slings (ASME B30.9), hooks (ASME B30.10), rigging hardware (ASME B30.26), or other special devices shall comply with the inspection requirements in the applicable volume.

(a) *Initial Inspection*

(1) New and reinstalled grapples shall be inspected prior to initial use to verify compliance with applicable provisions of this Volume.

(2) Altered or repaired grapples shall be inspected. The inspection may be limited to the components affected by the alteration or repair, as determined by a qualified person.

(b) *Inspection Intervals.* Inspection procedures for grapples in regular service are divided into two general classifications, based upon the intervals at which the inspections shall be performed. The intervals, in turn, are dependent upon the nature of the critical components of the grapple and the degree of their exposure to wear, deterioration, or malfunction. The two general classifications are designated as *frequent* and *periodic*, with respective intervals between inspections as defined below.

(1) *Frequent Inspection.* Visual examination by the operator or other designated persons with records not required.

(-a) Normal service — monthly

(-b) Heavy service — weekly to monthly

(-c) Severe service — daily to weekly

(-d) Special or infrequent service — as recommended by a qualified person before and after each lift

(2) *Periodic Inspection.* Visual inspection making records of apparent external conditions to provide the basis for a continuing evaluation.

(-a) Normal service for equipment in place — yearly

(-b) Heavy service for equipment in place — quarterly

(-c) Severe service for equipment in place — monthly

(-d) Special or infrequent service — as recommended by a qualified person before the first lift and as directed by the qualified person for any subsequent lifts

20-5.3.2 Frequent Inspection

Items such as the following shall be inspected for damage at intervals as defined in [para. 20-5.3.1\(b\)\(1\)](#), including observations during operation for any indications of damage that might appear between inspections. A qualified person shall determine whether any indications of damage constitute a hazard or will require more frequent inspection. For all grapples, inspect

(a) structural members for deformation, cracks, or excessive wear on any part of the grapple

(b) pins and bushings

(c) hydraulic lines

(d) hydraulic cylinders

(e) loose bolts

(f) for combination magnet/grapples, inspect the lifting magnet per [para. 20-4.3.2](#)

(g) for electrohydraulic grapples, inspect all electrical conductors that are visible without disassembly

(h) missing or illegible operating control markings

20-5.3.3 Periodic Inspection

Complete inspections of grapples shall be performed and recorded at intervals as defined in [para. 20-5.3.1\(b\)\(2\)](#). Any deficiencies, such as those listed below, shall be examined by a qualified person and determination made as to whether they constitute a hazard. These inspections shall include the requirements of [para. 20-5.3.2](#) and, in addition, items such as the following:

(a) all members, fasteners, and lifting parts shall be inspected for deformation, wear, and corrosion

(b) hydraulic hose, fittings, and tubing inspection

(1) evidence of leakage at the surface of flexible hose or its junction with metal couplings

(2) blistering or abnormal deformation of the outer covering of the hydraulic hose

(3) leakage at threaded or clamped joints that cannot be eliminated by normal tightening or recommended procedures

(4) evidence of excessive abrasion or scrubbing on the outer surface of a hose, rigid tube, or fitting

(c) hydraulic motors

(1) loose bolts or fasteners

(2) leaks at joints between sections

(3) shaft seal leaks

(4) unusual noises or vibration

(5) loss of operating speed

(6) excessive heating of the fluid

(7) loss of pressure

(d) hydraulic cylinders

(1) drifting caused by fluid leaking across the piston seals

(2) rod seal leakage

(3) leaks at welded joints

(4) scored, nicked, or dented cylinder rods

(5) dented case (barrel)

(6) loose or deformed rod eyes or connecting joints

(e) for combination magnet/grapples, inspect the magnet per [para. 20-4.3.3](#)

(f) for electrohydraulic grapples, all electrical components, including meters, indicators, and alarms, shall be tested for proper operation and condition

20-5.3.4 Grapples Not in Regular Use

A grapple that has been idle for a period of 1 month to 1 yr shall be inspected in accordance with [para. 20-5.3.2](#) before being placed in service. A grapple that has been



period of 1 yr or more shall be inspected in accordance with para. 20-5.3.3 before being returned to service.

20-5.3.5 Inspection Records

Dated inspection reports shall be made on critical items such as those listed in para. 20-5.3.3. Records should be available for each periodic inspection and when the grapple is either altered or repaired.

(18) 20-5.3.6 Repairs

Damage disclosed by the inspection requirements of Section 20-5.3 shall be corrected according to the procedures outlined in para. 20-5.3.8 before normal operation of the grapple is resumed, unless a qualified person determines the damage does not constitute a hazard. Repairs of slings (ASME B30.9), hooks (ASME B30.10), rigging hardware (ASME B30.26), or other special devices shall comply with repair requirements in the applicable volumes or standards.

(18) 20-5.3.7 Testing

(a) New and reinstalled grapples shall be tested by a qualified person, or a designated person under the direction of the manufacturer or a qualified person prior to initial use, to verify compliance with applicable provisions of this Volume, including a visual inspection to verify that the grapple contains no visible indications of hazardous conditions.

(b) Altered or repaired grapples shall be tested by a qualified person, or a designated person under the direction of the manufacturer or a qualified person. This test may be limited to the components affected by the alteration or repair, as determined by a qualified person with guidance from the manufacturer.

(c) All indicator lights, gages, horns, bells, alarms, pointers, and other warning devices shall be tested.

(d) Dated reports of all operational tests shall be filed.

(18) 20-5.3.8 Maintenance

(a) *Maintenance Program.* A maintenance program shall be established and be based on recommendations made by the grapple manufacturer. If a qualified person determines it is appropriate, the program should also include that individual's additional recommendations based on a review of the grapple application and operations.

(b) *Maintenance Procedure*

(1) Before maintenance is started on a grapple or its controls, the following precautions shall be taken:

(-a) all sources of grapple power shall be disconnected, locked out, and tagged "Out of Service"

(-b) relieve fluid pressure from all circuits before loosening or removing fluid power components

(-c) a grapple removed from service for repair shall be tagged "Out of Service"

(2) Only designated personnel shall perform maintenance, repairs, and tests when required. All moving parts of the grapple for which lubrication is specified should be regularly lubricated. The manufacturer's recommendations as to the points and frequency of lubrication, and types of lubricant, should be used.

(3) Replacement parts shall be at least equal to the original manufacturer's specifications.

(4) After adjustments and repairs have been made, the grapple shall not be returned to service until it has been inspected according to para. 20-5.3.3.

(5) Dated records of repairs and replacements should be made.

SECTION 20-5.4: OPERATION

20-5.4.1 Operators

Grapples shall be operated only by trained, designated persons.

20-5.4.2 Qualifications

(18)

Qualifications for operators of grapples are as follows:

(a) The operator shall be instructed in the use of the grapple by a designated person before handling the grapple. Instructions should include, but not be limited to, the following:

(1) instructions in any special operations or precautions

(2) the manufacturer's suggested operating procedures

(3) storage of the grapple to protect it from damage

(4) not exceeding the rated load of the grapple nor the material handler by the combined weight of the grapple and the load

(b) The operator shall demonstrate the ability to operate the grapple as instructed before assuming responsibility for using the grapple.

(c) The operator shall demonstrate an understanding of standard hand signals when applicable.

20-5.4.3 Responsibilities

While the organizational structure of various projects may differ, the following roles are described here for purposes of delineating responsibilities. All responsibilities listed below shall be assigned in the worksite organization. (A single individual may perform one or more of these roles.)

operator: directly controls the lifting device's functions.

owner: has custodial control of a lifting device by virtue of lease or ownership.

These persons and roles may or may not match the persons and roles associated with the hoisting equipment in use.



Responsibilities of the Lifting Device

responsibilities of the lifting device owner shall be the following:

- (a) providing a lifting device, and all necessary components specified by the manufacturer, that meets the requirements of Sections 20-5.2 and 20-5.3 as well as specific job requirements.
- (b) providing all applicable operating instructions.
- (c) providing field assembly, and disassembly (if applicable), operation and maintenance information, and warning decals and placards installed as prescribed by the lifting device manufacturer.
- (d) establishing an inspection, testing, and maintenance program in accordance with Section 20-5.3.
- (e) using designated personnel to perform the required maintenance, repair, and inspections.
- (f) ensuring that the lifting device is in proper operating condition prior to initial use at the worksite by the following:
 - (1) verifying that all inspections have been performed as required by Section 20-5.3
 - (2) verifying that the lifting device has the necessary lifting capacity to perform the proposed lifting operations in the planned configuration
 - (g) using operators that meet the requirements of para. 20-5.4.2.
 - (h) ensuring that all personnel involved in maintenance, repair, assembly, disassembly, and inspection are aware of their responsibilities, assigned duties, and the associated hazards.
 - (i) determining if additional regulations are applicable to lifting device operations.
 - (j) ensuring that conditions that may adversely affect lifting device operations are addressed. Such conditions include, but are not limited to, the following:
 - (1) wind velocity or gusting winds
 - (2) precipitation
 - (3) fog
 - (4) extreme temperatures
 - (5) lighting
 - (k) addressing safety concerns raised by the operator or other personnel and being responsible if he decides to overrule those concerns and directs lifting device operations to continue. (In all cases, the manufacturer's criteria for safe operation and the requirements of this Volume shall be followed.)

20-5.4.3.2 Responsibilities of Operators. The operator shall be responsible for the following listed items. The operator shall not be responsible for hazards or conditions that are not under his direct control and that adversely affect operation of the lifting device. Whenever the operator has doubt as to the safety of lifting device operations, the operator shall place the load in a safe condition and stop the lifting device's functions in a controlled manner. Use of the lifting device shall resume only after safety concerns

have been addressed or the continuation of lifting device operations is directed by the owner.

The operator's responsibilities shall include the following:

- (a) reviewing the requirements for the lifting device with the owner before operations.
- (b) knowing what types of site conditions could adversely affect the operation of the lifting device and consulting with the owner concerning the possible presence of those conditions.
- (c) understanding and applying the information contained in the lifting device manufacturer's operating manual.
- (d) understanding the lifting device's functions and limitations as well as its particular operating characteristics.
- (e) performing a Frequent Inspection as specified in para. 20-5.3.2.
- (f) promptly reporting the need for any adjustments or repairs to a designated person.
- (g) following applicable lock out/tag out procedures.
- (h) not operating the lifting device when physically or mentally unfit.
- (i) ensuring that all controls are in the off or neutral position and that all personnel are in the clear before energizing the lifting device.
- (j) not engaging in any practice that will divert his attention while operating the lifting device.
- (k) testing the lifting device function controls that will be used and operating the lifting device only if those function controls respond properly.
- (l) operating the lifting device's functions, under normal operating conditions, in a smooth and controlled manner.
- (m) knowing and following the procedures specified by the manufacturer or approved by a qualified person, for assembly, disassembly, setting up, and reeving/rigging of the lifting device.
- (n) considering all factors known that might affect the lifting device capacity and informing the owner of the need to make appropriate adjustments.
- (o) understanding basic load attachment procedures.
- (p) responding only to instructions from designated persons. However, the operator shall obey a stop order at all times, no matter who gives it.

20-5.4.4 Grapple Operating Practices

(18)

(a) Grapples shall be operated by the following qualified personnel:

- (1) designated persons
- (2) trainees under the supervision of a designated person, the number of trainees permitted to be supervised by a single designated person, the physical location of the designated person while supervising, and the type of communication required between the designated



- and the trainee shall be determined by a qualified
- (j) maintenance and test personnel, when it is necessary in the performance of their duties
- (b) The grapple shall not be loaded in excess of its rated load or handle any load for which it is not designed.
- (c) Properly attaching the lifting device to the hook, shackle, or other load handling device.
- (d) The grapple shall be applied to the load in accordance with the instruction manual.
- (e) The temperature of the load shall not exceed the maximum allowable limits of the grapple.
- (f) Do not allow load or grapple to come into contact with any obstruction.
- (g) The operator shall ensure that the lifting device is adequately protected from damage during use.
- (h) The operator shall land any attached load and store the lifter before leaving the lifting device. The operator shall not leave suspended loads unattended.
- (i) The operator shall not ride, or allow others to ride loads or the grapple.
- (j) The operation of the lifter shall be observed during use. Any deficiency observed shall be examined by a designated person. If the deficiency constitutes a hazard, the

lifter shall be removed from service and tagged "Out of Service." Any indication of a hazardous condition shall be reported to a qualified person for evaluation.

20-5.4.5 Miscellaneous Operating Practices

- (a) An operator shall not use a grapple that is tagged "Out of Service" or otherwise designated as nonfunctioning.
- (b) "Out of Service" tags on grapples shall not be removed without the approval of the person placing them or a designated person.
- (c) The grapple, when not in use, shall be stored.
- (d) Caution should be taken that operating markings or tags shall not be removed or defaced. Missing or illegible markings or tags shall be replaced.

SECTION 20-5.5: INSTRUCTION MANUALS

Operating instructions and maintenance and parts information shall be furnished by the manufacturer.

آریا ایمن آوات

Chapter 20-6 Clamps

(18)

SECTION 20-6.1: SCOPE

Chapter 20-6 applies to the classification, marking, construction, installation, inspection, testing, maintenance, and operation of clamps. For proper function, a clamp relies on a nonvertical force against the surface of the load to generate a vertical lifting force, or a force normal to the surface of the load or anchorage to prevent motion of the clamp relative to the load or anchorage, or both. These forces may be generated by gravity or by screw, cam, or similar device. Clamps included in this Chapter may be used for attaching loads to a hoist, or for other load handling purposes such as anchoring or positioning. Within Chapter 20-6, the clamps are categorized as follows:

- (a) supporting clamps (see Figure 20-6.0-1 for examples).
- (b) friction-type pressure-gripping clamps (see Figure 20-6.0-2 for examples).
- (c) indentation-type pressure-gripping clamps (see Figure 20-6.0-3 for examples).
- (d) anchoring and positioning clamps. Anchoring clamps are used for suspending or attaching detachable rigging hardware. Positioning clamps are used to hold or locate parts during assembly operations (see Figure 20-6.0-4 for examples).
- (e) hybrid clamps that use a combination of categories above (see Figure 20-6.0-5 for example).

SECTION 20-6.2: MARKING, CONSTRUCTION, AND INSTALLATION

20-6.2.1 Marking

(a) *Rated Load.* The rated maximum and minimum (if applicable) loads of the clamp shall be legibly marked on its main structure or on a tag attached to its main structure where it is visible. The minimum load (if applicable) shall be defined by the manufacturer or a qualified person.

(b) *Identification.* Clamps shall be marked with, but not limited to, the following information:

- (1) manufacturer's name and contact information
- (2) serial number (unique unit identifier)
- (3) clamp weight, if over 100 lb (45 kg)
- (4) rated maximum load [as described in (a)]
- (5) rated minimum load [as described in (a)]
- (6) ASME BTH-1 Design Category

(7) ASME BTH-1 Service Class

(8) clamps that are designed only for anchoring or positioning shall be marked accordingly

(c) *Repaired or Altered Clamps.* Repaired or altered clamps shall be provided with identification displaying, but not limited to, the following information:

(1) name and contact information of the repairer or alterer

(2) repairer's or alterer's unit identification

(3) clamp weight (if altered)

(4) rated maximum load (if altered) [as described in

(a)]

(5) rated minimum load (if altered) [as described in

(a)]

(6) ASME BTH-1 Design Category (if altered)

(7) ASME BTH-1 Service Class (if altered)

This requirement is not applicable to repairs limited to replacement of maintenance parts.

(d) *Product Safety Labels*

(1) Where size and shape of the clamp allow, clamps shall have labels affixed to them in a readable position, that include the appropriate signal word, according to ANSI Z535.4-2011, to bring the label to the attention of the operator. The label should include cautionary language identifying hazards, methods for accident prevention, and refer to instruction manuals for additional information.

(2) Where size or shape of the clamp prohibits the inclusion of all or any such markings, a label shall be affixed, referring user to consult manufacturer's instruction manual for product safety information.

20-6.2.2 Construction

The manufacturer shall verify that clamps are designed in accordance with ASME BTH-1.

Clamps shall be designed to ASME BTH-1 Design Category B (static strength criteria) and the proper Service Class (fatigue life criteria) selected for its number of load cycles, unless a qualified person representing the owner, purchaser, or user of the clamp determines that ASME BTH-1 Design Category A is appropriate.

Design Category A shall only be designated when the magnitude and variation of loads applied to the clamp are predictable and where the loading and environmental conditions are accurately defined, where service is not

Figure 20-6.0-1 Load-Supporting Clamps

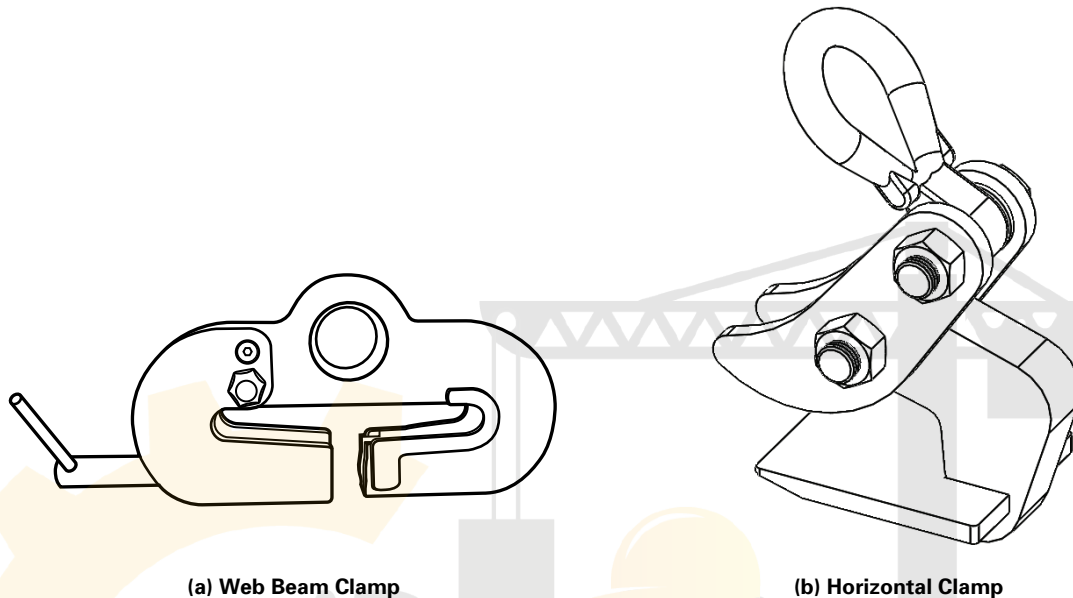

severe, and where the anticipated number of load cycles does not exceed Service Class 0.

(a) *Welding.* Welding shall be in accordance with ASME BTH-1, para. 1-4.6.

(b) *Guards for Moving Parts.* Exposed moving parts, such as, but not limited to, gearing and projecting shafts, that constitute a hazard under normal operating conditions shall be guarded.

(c) *Electrical Equipment.* External power supply, electrical equipment, and wiring for clamps shall be in accordance with ASME BTH-1.

(d) *Alterations.* Clamps may be altered or rerated, provided such alterations are analyzed and approved by the equipment manufacturer or a qualified person. A rerated clamp, or one whose components have been altered, shall conform to this paragraph and be tested according to para. 20-6.3.8. The new rated load shall be displayed in accordance with para. 20-6.2.1.

(e) *Slings.* When employed, slings shall meet the requirements of ASME B30.9.

(f) *Hooks.* When employed, hooks shall meet the requirements of ASME B30.10.

(g) *Rigging Hardware.* When employed, rigging hardware shall meet the requirements of ASME B30.26.

20-6.2.3 Installation

The clamp shall be installed in accordance with the manufacturer's instructions.

SECTION 20-6.3: INSPECTION, TESTING, AND MAINTENANCE

20-6.3.1 Inspection Classification

General. All inspections shall be performed by a designated person. Any deficiencies identified shall be examined and a determination made by a qualified person as to whether they constitute a hazard, and if so, what additional steps need to be taken to address the hazard.

Inspection of slings (ASME B30.9), hooks (ASME B30.10), rigging hardware (ASME B30.26), or other devices shall comply with the inspection requirements in the applicable volume.

(a) Initial Inspection

(1) New and reinstalled clamps shall be inspected prior to initial use to verify compliance with applicable provisions of this Volume.

(2) Altered or repaired clamps shall be inspected. The inspection may be limited to those components affected by the alteration or repair, as determined by a qualified person.

(b) *Inspection Intervals.* Inspection procedure for clamps in regular service is divided into three general classifications based upon the intervals at which inspection should be performed. The intervals, in turn, are dependent upon the critical components of the clamps and the degree of their exposure to wear or deterioration. The three general classifications are herein designated as *every lift*, *frequent*, and *periodic*, with respective intervals between inspections as defined below.

Figure 20-6.0-2 Friction-Type Pressure-Gripping Clamps

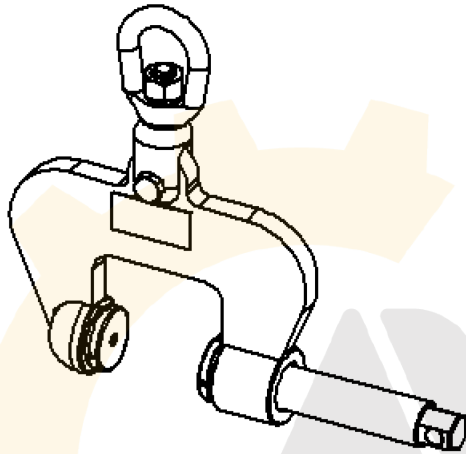

(a) Screw Clamp

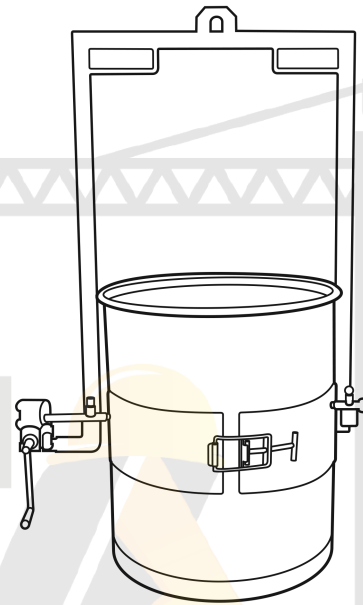

(b) Drum of Cylinder Friction-Type Cam Clamp
(Lifts by Friction)

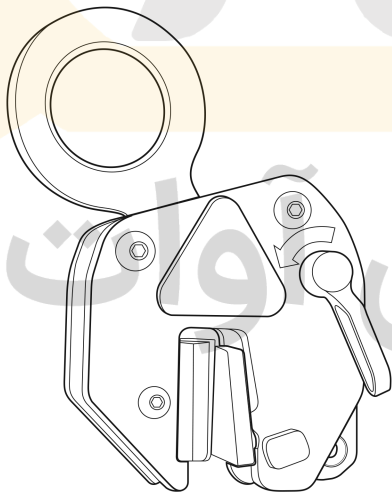

(c) Plate Clamp

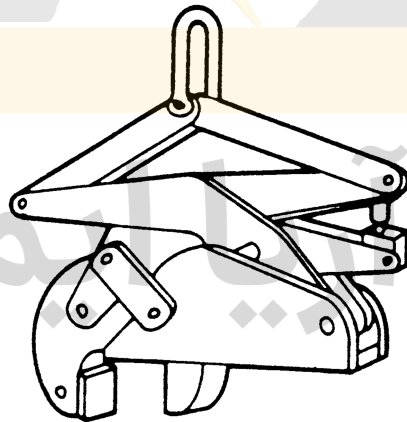

(d) Vertical Axis Coil Clamp

Figure 20-6.0-2 Friction-Type Pressure-Gripping Clamps (Cont'd)

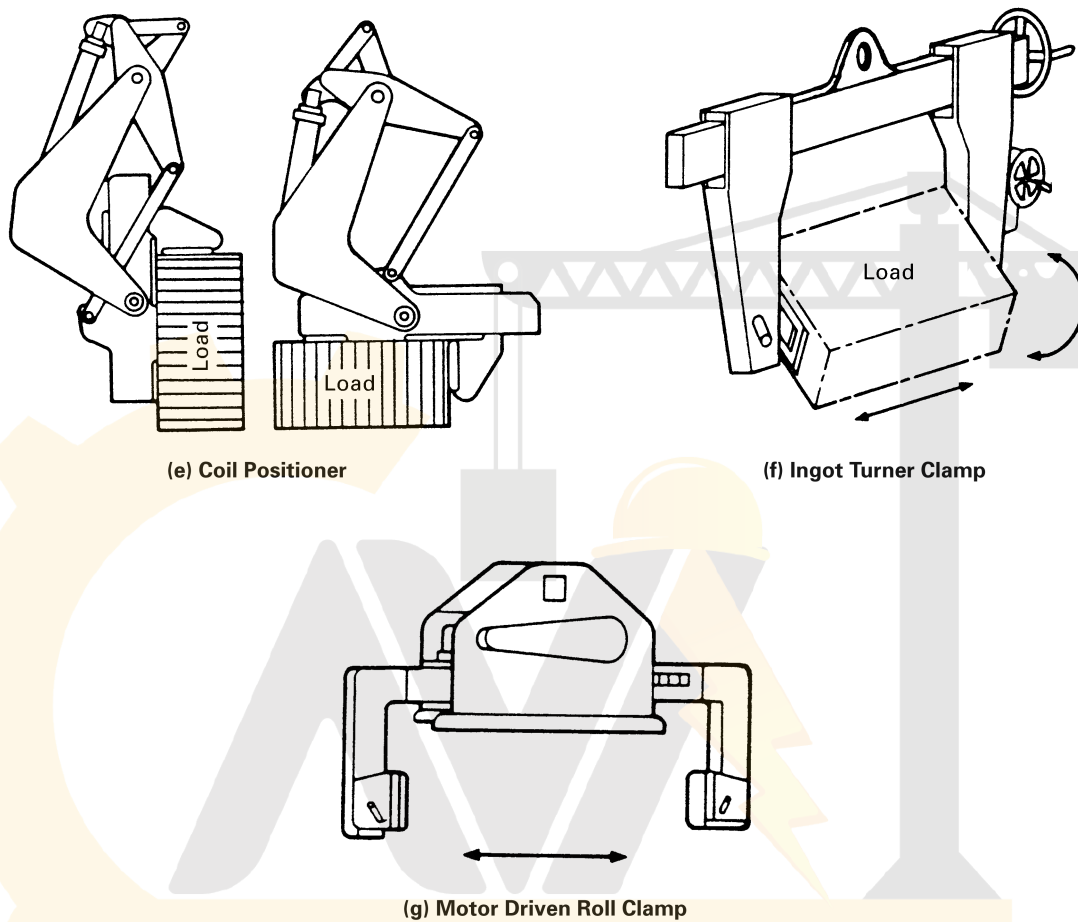

(1) *Every Lift Inspection.* Visual examination before and during each use of the clamp.

(2) *Frequent Inspection.* Visual examinations with records not required.

(-a) Normal service — monthly

(-b) Heavy service — weekly to monthly

(-c) Severe service — daily to weekly

(-d) Special or infrequent service — as recommended by a qualified person before and after each lift

(3) *Periodic Inspection.* Visual inspection making records of apparent external conditions to provide the basis for a continuing evaluation. An external code mark on the clamp is an acceptable identification in lieu of records.

(-a) Normal service — yearly

(-b) Heavy service — semiannually

(-c) Severe service — quarterly

(-d) Special or infrequent service — as recommended by a qualified person before the first such lift and as directed by the qualified person for any subsequent lifts

20-6.3.2 Every Lift Inspection

Items such as the following shall be inspected before and/or during every lift for any indication of damage as specifically indicated, including observations during operation for any damage that might occur during the lift:

(a) clamp load contact surface condition

(b) engagement

(c) obvious clamp damage

20-6.3.3 Frequent Inspection

Clamps shall be inspected for damage at intervals as defined in [para. 20-6.3.1\(b\)\(2\)](#), including observations during operation for any indications of damage that might appear between inspections. A qualified person shall determine whether any indications of damage

Figure 20-6.0-3 Indentation-Type Pressure-Gripping Clamps

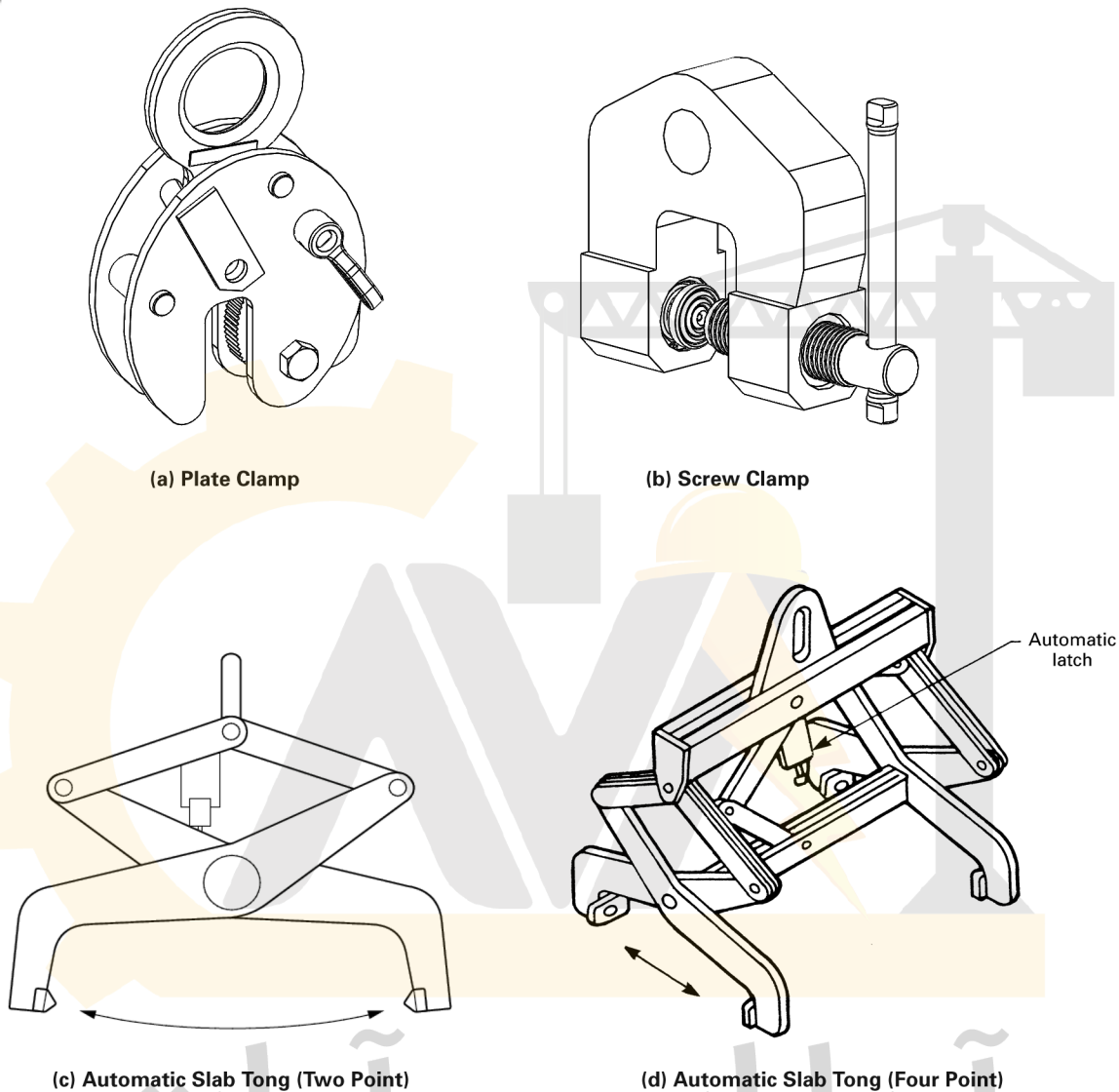

constitute a hazard or will require more frequent inspection. Conditions such as those listed in [para. 20-6.3.7](#), or any other condition that may constitute a hazard, shall cause the clamp to be removed from service. Clamps shall not be returned to service until approved by a qualified person.

20-6.3.4 Periodic Inspection

Documented inspection of the clamp shall be performed at intervals as defined in [para. 20-6.3.1\(b\)\(3\)](#), including observations during operation for any indications of damage. If external conditions indicate, disassembly shall be performed for a detailed inspection. A qualified person shall determine whether any indications of damage constitute a hazard or will require more frequent

inspection. Conditions such as those listed in [para. 20-6.3.7](#), or any other condition that may result in a hazard, shall cause the clamp to be removed from service. Clamps shall not be returned to service until approved by a qualified person. The inspection and documentation shall be based on the manufacturer's instructions or [para. 20-6.3.7](#).

20-6.3.5 Clamps Not in Regular Use

A clamp that has been idle for a period of 1 month to 1 yr shall be inspected in accordance with [para. 20-6.3.3](#) before being placed in service. A clamp that has been idle for a period of 1 yr or more shall be inspected in accordance with [para. 20-6.3.4](#) before being returned to service.

Figure 20-6.0-4 Anchoring and Positioning Clamps

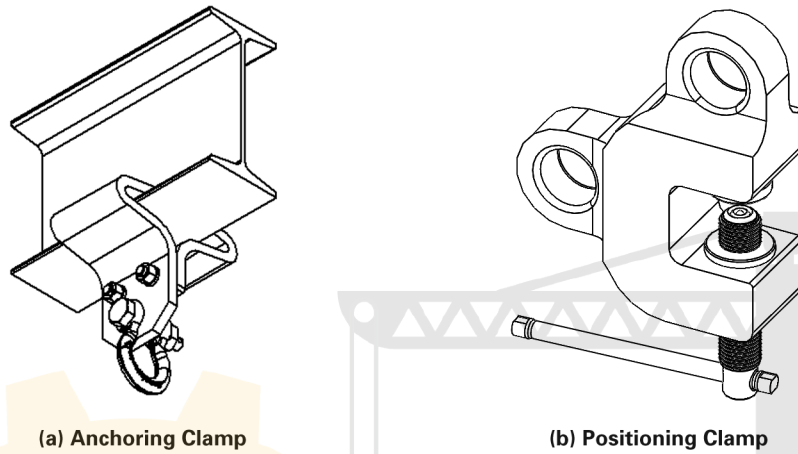
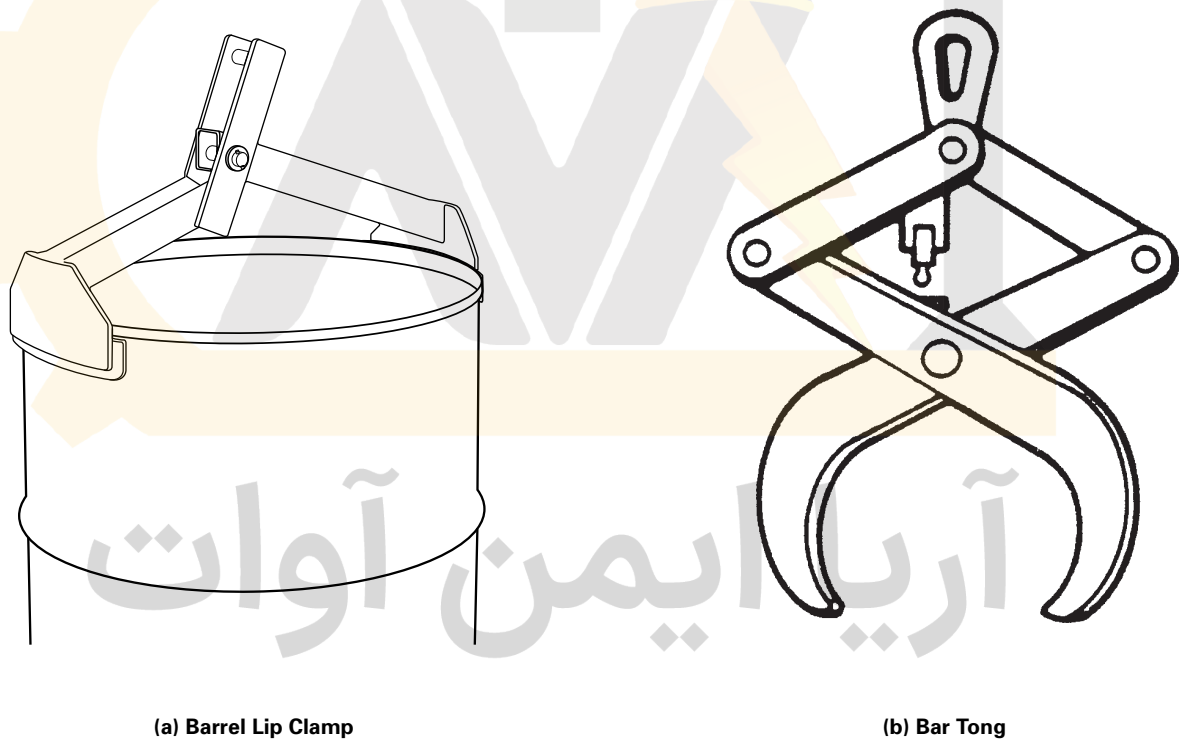

Figure 20-6.0-5 Hybrid Clamps



20-6.3.6 Inspection Records

Dated inspection reports shall be made on critical items such as those listed in [para. 20-6.3.7](#). Records should be available for each periodic inspection and when the clamp is either altered or repaired.

20-6.3.7 Removal Criteria

A clamp shall be removed from service if conditions (if applicable) such as the following are present (limits established by the manufacturer or qualified person) and shall only be returned to service when approved by a qualified person:

- (a) deformation, cracks, or wear
- (b) loose or missing guards, fasteners, covers, stops, or nameplates



- (e) pitting or corrosion
- (f) excessive nicks or gouges
- (g) indications of heat damage, including weld spatter or arc strikes
- (f) evidence of unauthorized welding or modification
- (g) unauthorized replacement components
- (h) improper assembly
- (i) gripping teeth
 - (1) severely worn
 - (2) broken, chipped, or damaged
 - (3) clogged with foreign material
- (j) gripping surfaces
 - (1) contamination
 - (2) excessive surface wear
 - (3) lack of integrity of the gripping material
 - (4) lack of bond between gripping material and metal backing
- (k) damaged or distorted pins
- (l) bail
 - (1) severely worn
 - (2) bent, twisted, distorted, stretched, cracked, or broken
- (m) body
 - (1) cracked welds
 - (2) bent, twisted, distorted, stretched, elongated pin holes, or cracks
- (n) damaged, distorted, or worn threads including foreign material on the threads
- (o) impaired, seized, or bound cam, linkage, bail movement, or locking lever
- (p) deformed, broken, or missing spring(s)
- (q) broken, worn, or loose cam
- (r) other conditions, including visible damage, that cause doubt as to continued safe use

20-6.3.8 Repairs

Damage disclosed by the inspection requirements of Section 20-6.3 shall be corrected according to the procedures outlined in para. 20-6.3.10 before operation of the clamp is resumed, unless a qualified person determines the damage does not constitute a hazard. Repairs of slings (ASME B30.9), hooks (ASME B30.10), rigging hardware (ASME B30.26), or other devices shall comply with repair requirements in the applicable volumes or standards.

20-6.3.9 Testing

20-6.3.9.1 Operational Tests

(a) New clamps shall be tested by a qualified person, or a designated person under the direction of the manufacturer or a qualified person, prior to initial use to verify compliance with applicable provisions of this Volume, including, but not limited to, the following:

(1) *Moving Parts.* Clamps with moving parts shall be tested to determine that the clamp operates in accordance with manufacturer's instructions.

(2) *Locking Mechanisms.* Clamps with manually operated or automatic locking mechanisms shall be tested to determine that the locking mechanism operates in accordance with manufacturer's instructions.

(b) Altered or repaired clamps shall be tested by a qualified person, or a designated person under the direction of the manufacturer or a qualified person. This test may be limited to the components affected by the alteration or repair, as determined by a qualified person with guidance from the manufacturer.

(c) All indicator lights, gages, horns, bells, alarms, pointers, and other warning devices shall be tested.

(d) Dated reports of all operational tests shall be filed.

20-6.3.9.2 Load Test

(a) Prior to initial use, all new, altered, or repaired clamps should be tested and inspected. If performed, tests shall be done by a qualified person, or a designated person under the direction of the manufacturer or a qualified person and a written report be furnished, confirming the load rating of the clamp. The load rating should not be more than 80% of the maximum load sustained during the test. Test loads shall not be more than 125% of the rated load unless otherwise recommended by the manufacturer. Test reports should be available.

(b) The load test, if made, shall consist of the following operations as a minimum:

(1) Hoist the test load a sufficient distance to ensure the load is supported by the clamp, or apply the required load if the test is made using a testing machine.

(2) After the test load is released, visually inspect the clamp for deformation, cracks, or other defects.

(c) Tests of altered or repaired clamps may be limited to the components affected by the alteration or repair, as determined by a qualified person with guidance from the manufacturer and shall be tested to at least the rated load.

20-6.3.10 Maintenance

(a) *Maintenance Program.* A maintenance program shall be established and be based on recommendations made by the clamp manufacturer. If a qualified person determines it is appropriate, the program should also include that individual's additional recommendations based on a review of the clamp application and operation.

(b) *Maintenance Procedure*

(1) Before adjustments and repairs are started on a clamp, the following precautions shall be taken:

(-a) All sources of power shall be disconnected, locked out, and tagged "Out of Service."

(-b) A clamp removed from service for repair shall be tagged "Out of Service."

(2) Only designated persons shall perform adjustments, repairs, and tests.



Replacement parts shall be at least equal to the manufacturer's specifications.

(4) After adjustments and repairs have been made, the clamp shall not be returned to service until it has been inspected according to [para. 20-6.3.4](#).

(5) Dated records of repairs and replacements should be made.

(6) Any hazardous conditions disclosed by the inspection of [para. 20-6.3.1](#) shall be corrected before normal operation of the clamp is resumed. Adjustments and repairs shall be done under the direction of, or by, a qualified person.

SECTION 20-6.4: OPERATION

20-6.4.1 Operators

Clamps shall be operated only by trained, designated persons.

20-6.4.2 Qualifications

Qualifications for operators of clamps are as follows:

(a) The operator shall be instructed in the use of the clamp by a designated person. Instructions should include, but not be limited to, the following:

(1) application of the clamp to the load and material-handling device, and adjustments, if any, that adapt the clamp to various sizes or kinds of loads

(2) instructions in any special operations or precautions

(3) the manufacturer's suggested operating procedures

(4) characteristics of the load itself required for operation of the clamp, such as, but not limited to, balance, surface cleanliness, flatness, rigidity, and thickness

(5) storage of the clamp to protect it from damage

(6) not exceeding the rated load of the clamp nor the capacity of the hoisting equipment by the combined weight of the load, the clamp, and rigging

(7) the proper attachment of adapters to the clamp for special load handling

(b) The operator shall demonstrate the ability to operate and inspect the clamp as instructed before assuming responsibility for using the clamp.

(c) The operator shall be familiar with standard hand signals when applicable.

20-6.4.3 Responsibilities

While the organizational structure of various projects may differ, the following roles are described here for purposes of delineating responsibilities. All responsibilities listed below shall be assigned in the worksite organization. (A single individual may perform one or more of these roles.)

operator: directly controls the clamp's functions.

owner: has custodial control of a clamp by virtue of lease or ownership.

These persons and roles may or may not match the persons and roles associated with the hoisting equipment.

20-6.4.3.1 Responsibilities of the Clamp Owner. The responsibilities of the clamp owner shall include the following:

(a) providing a clamp, and all necessary components specified by the manufacturer, that meets the requirements of [Sections 20-6.2](#) and [20-6.3](#) as well as specific job requirements.

(b) providing all applicable operating instructions.

(c) providing field assembly, and disassembly (if applicable), operation and maintenance information, and warning decals and placards installed as prescribed by the clamp manufacturer.

(d) establishing an inspection, testing, and maintenance program in accordance with [Section 20-6.3](#).

(e) using designated personnel to perform the required maintenance, repair, and inspections.

(f) ensuring that the clamp is in proper operating condition prior to initial use at the worksite by the following:

(1) verifying that all inspections have been performed as required by [Section 20-6.3](#)

(2) verifying that the clamp has the necessary lifting capacity to perform the proposed lifting operations in the planned configuration

(g) using operators that meet the requirements of [para. 20-6.4.2](#).

(h) ensuring that all personnel involved in maintenance, repair, assembly, disassembly, and inspection are aware of their responsibilities, assigned duties, and the associated hazards.

(i) determining if additional regulations are applicable to clamp operations.

(j) ensuring that conditions that may adversely affect clamp operations are addressed. Such conditions include, but are not limited to, the following:

(1) wind velocity or gusting winds

(2) precipitation

(3) fog or humidity

(4) extreme temperatures

(5) lighting

(k) addressing safety concerns raised by the operator or other personnel and being responsible if they and a qualified person decide to overrule those concerns and directs clamp operations to continue. (In all cases, the manufacturer's criteria for safe operation and the requirements of this Volume shall be followed.)

20-6.4.3.2 Responsibilities of Operators. The operator shall be responsible for the following listed items. The operator shall not be responsible for hazards or conditions that are not under his direct control and that adversely affect operation of the



ver the operator has doubt as to the safety of operations, the operator shall place the load in a safe and stop the lift in a controlled manner. Use of the clamp shall resume only after safety concerns have been addressed or the continuation of clamp usage is directed by the owner and a qualified person.

The operator's responsibilities shall include the following:

(a) reviewing the requirements for the clamp with the owner before operations.

(b) knowing what types of site conditions could adversely affect the operation of the clamp and consulting with the owner concerning the possible presence of those conditions.

(c) understanding and applying the information contained in the clamp manufacturer's operating manual.

(d) understanding the clamp's functions and limitations as well as its particular operating characteristics.

(e) ensuring an inspection is performed prior to every lift as specified in [para. 20-6.3.2](#).

(f) promptly reporting the need for any adjustments or repairs to a designated person.

(g) following applicable lock out/tag out procedures.

(h) not using the clamp when physically or mentally unfit.

(i) ensuring that all personnel are in the clear before initiating the lift.

(j) not engaging in any practice that will divert his attention while using the clamp.

(k) inspecting the clamp for proper function before use.

(l) using the clamp in a smooth and controlled manner.

(m) knowing and following the procedures specified by the manufacturer or approved by a qualified person, concerning attachment of the clamp.

(n) considering all factors known that might affect the clamp capacity and informing the owner of the need to make appropriate adjustments.

(o) responding only to instructions from designated persons. However, the operator shall obey a stop order at all times, no matter who gives it.

(p) not making alterations or modifications to the clamp.

20-6.4.4 Clamp Operating Practices

(a) Selection of the clamp and proper setup is as follows:

(1) Follow manufacturer's procedures to prevent load disengagement.

(2) Verify load meets or exceeds the minimum load required for proper clamp function.

(3) Use proper clamp for material hardness, material type, surface conditions, etc.

(4) Do not lift multiple or sagging plates unless approved by the manufacturer.

(5) Assure all moving clamp components move freely.

(6) Do not use two or more vertical clamps on opposite ends of a plate to lift the plate in the horizontal position unless approved by the manufacturer.

(7) When locks are provided on the clamp, they shall be used.

(8) A clamp shall only be used within its thickness range.

(9) Reduce the rated load as required by the manufacturer for lifts other than a straight lift.

(b) Clamps shall be operated only by the following qualified personnel:

(1) designated persons

(2) trainees under the supervision of a designated person, the number of trainees permitted to be supervised by a single designated person, the physical location of the designated person while supervising, and the type of communication required between the designated person and the trainee shall be determined by a qualified person

(3) maintenance and test personnel, when it is necessary in the performance of their duties

(4) inspectors

(c) Ensure the weight of the load and its approximate center of gravity have been obtained, provided, or calculated.

(d) The clamp shall not be loaded in excess of its rated load or handle any load for which it is not designed.

(e) Properly attaching the lifting device to the hook, shackle, or other load handling device.

(f) Clamps and the load must be clean in accordance with the instruction manual.

(g) The clamp shall be applied to the load in accordance with the instruction manual.

(h) Before lifting, make sure that clamp slings (as applicable) are not kinked or twisted.

(i) Care should be taken to make certain the load is correctly distributed for the clamp(s) being used.

(j) The temperature of the load shall not exceed the maximum allowable limits of the clamp unless approved by the manufacturer or qualified person.

(k) Verify that the load is well secured and properly balanced in the lifting device when it is initially lifted.

(l) Do not allow load or clamp to come into contact with any obstruction.

(m) Ensure that the lifting device is adequately protected from damage during use.

(n) Recheck clamp engagement and clamping force whenever the load has been placed on a supporting surface.

(o) The clamp shall not be used for side pulls or sliding the load unless specifically authorized by the manufacturer or a qualified person.

(p) The operator shall land any attached load and disengage the clamp before leaving the clamp. The operator shall not leave suspended loads unattended. Anchoring clamps are exempt from this requirement.



The operator shall not ride, or allow others to ride the clamp.

The operation of the clamp shall be observed before use and during a shift. Any deficiency observed shall be examined by a designated person. If the deficiency constitutes a hazard, the clamp shall be removed from service and tagged "Out of Service." Any indication of a hazardous condition shall be reported to a qualified person for evaluation.

(s) Loads shall be guided in such a manner as to avoid endangering hands or other body parts as the load is moved, or if it drops.

(t) When using two or more clamps, follow the manufacturer's instructions for multiple clamp use.

(u) A plate clamp(s) shall only be used to lift a single plate unless otherwise approved by clamp manufacturer.

20-6.4.5 Miscellaneous Operating Practices

(a) An operator shall not use a clamp that is tagged "Out of Service" or otherwise designated as nonfunctioning.

(b) "Out of Service" tags on clamps shall not be removed without the approval of the person placing them or a designated person.

(c) The clamp, when not in use, should be stored at an assigned location.

(d) Caution should be taken to ensure that operating markings or tags shall not be removed or defaced. Missing or illegible markings or tags shall be replaced.

SECTION 20-6.5: INSTRUCTION MANUALS

The manufacturer shall provide operating instructions, inspection and removal criteria, and maintenance and parts information. In addition, the manual shall also

provide a statement of those factors that alter the clamp's capacity and related limitations. Several factors known to affect a clamp's lifting capabilities are noted below and shall be included in the manual.

(a) *Temperature of Load.* The manufacturer's recommendations pertaining to operation of the clamp on loads at temperatures exceeding normal ambient temperatures.

(b) *Load Dimensions.* Define the limitations on the size of the load that is recommended.

(c) *Surface, Shapes, Material, and Surface Hardness Configuration.* Provide specific information on what surfaces, shapes, materials, and surface hardness the device is designed to handle, including factors such as rough surface finish, paper, dirt, rust, paint, and any other factors deemed important to the handling of loads.

(d) *Maintenance of Interfacing Surfaces.* Define the permissible amount of wear, distortion, or damage of the interface components.

(e) *Environmental.* Define conditions that adversely affect the lifting capacity including but not limited to wind, rain, snow, etc.

(f) *Lifting Angle Range.* Define limitations on the lifting angle range.

(g) *Minimum Lifting Force.* Define minimum lifting force necessary to actuate the clamping action. Minimum loads for pressure-gripping lifting and structural shape clamps are dependent on clamp wear and material hardness.

آریا ایمن آوات



30.20-2018

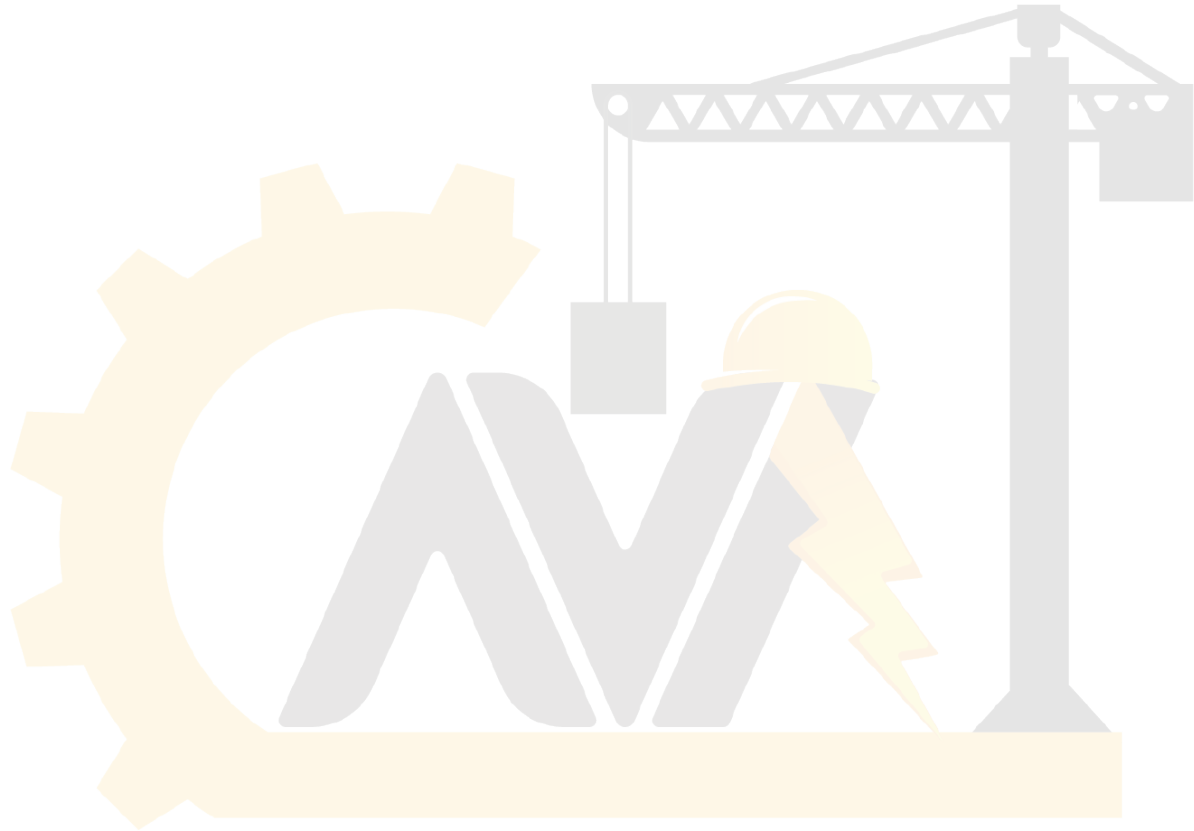

آریا ایمن آوات

ISBN 978-0-7918-7183-6



9 780791 871836



J 10018