



ASME B30.25-2018
(Revision of ASME B30.25-2013)

Scrap and Material Handlers

**Safety Standard for Cableways,
Cranes, Derricks, Hoists, Hooks, Jacks,
and Slings**

AN AMERICAN NATIONAL STANDARD



**The American Society of
Mechanical Engineers**



ASME B30.25-2018
(Revision of ASME B30.25-2013)

Scrap and Material Handlers

**Safety Standard for Cableways,
Cranes, Derricks, Hoists, Hooks, Jacks,
and Slings**

AN AMERICAN NATIONAL STANDARD



**The American Society of
Mechanical Engineers**

Two Park Avenue • New York, NY • 10016 USA



Date of Issuance: July 2, 2018

The next edition of this Standard is scheduled for publication in 2023. This Standard will become effective 1 year after the Date of Issuance.

ASME issues written replies to inquiries concerning interpretations of technical aspects of this Standard. Interpretations are published on the ASME website under the Committee Pages at <http://cstools.asme.org/> as they are issued.

Errata to codes and standards may be posted on the ASME website under the Committee Pages to provide corrections to incorrectly published items, or to correct typographical or grammatical errors in codes and standards. Such errata shall be used on the date posted.

The Committee Pages can be found at <http://cstools.asme.org/>. There is an option available to automatically receive an e-mail notification when errata are posted to a particular code or standard. This option can be found on the appropriate Committee Page after selecting "Errata" in the "Publication Information" section.

ASME is the registered trademark of The American Society of Mechanical Engineers.

This code or standard was developed under procedures accredited as meeting the criteria for American National Standards. The Standards Committee that approved the code or standard was balanced to assure that individuals from competent and concerned interests have had an opportunity to participate. The proposed code or standard was made available for public review and comment that provides an opportunity for additional public input from industry, academia, regulatory agencies, and the public-at-large.

ASME does not "approve," "rate," or "endorse" any item, construction, proprietary device, or activity.

ASME does not take any position with respect to the validity of any patent rights asserted in connection with any items mentioned in this document, and does not undertake to insure anyone utilizing a standard against liability for infringement of any applicable letters patent, nor assume any such liability. Users of a code or standard are expressly advised that determination of the validity of any such patent rights, and the risk of infringement of such rights, is entirely their own responsibility.

Participation by federal agency representative(s) or person(s) affiliated with industry is not to be interpreted as government or industry endorsement of this code or standard.

ASME accepts responsibility for only those interpretations of this document issued in accordance with the established ASME procedures and policies, which precludes the issuance of interpretations by individuals.

No part of this document may be reproduced in any form,
in an electronic retrieval system or otherwise,
without the prior written permission of the publisher.

The American Society of Mechanical Engineers
Two Park Avenue, New York, NY 10016-5990

Copyright © 2018 by
THE AMERICAN SOCIETY OF MECHANICAL ENGINEERS
All rights reserved
Printed in U.S.A.

CONTENTS

Foreword	v
Committee Roster	vi
B30 Standard Introduction	viii
Summary of Changes	xi
Chapter 25-0 Scope, Definitions, Personnel Competence, and References	1
Section 25-0.1 Scope of B30.25	1
Section 25-0.2 Definitions	1
Section 25-0.3 Personnel Competence	7
Section 25-0.4 References	7
Chapter 25-1 Construction and Characteristics	11
Section 25-1.1 Lift Capacity	11
Section 25-1.2 Backward Stability	11
Section 25-1.3 Swing Mechanism	12
Section 25-1.4 Handler Travel	12
Section 25-1.5 Controls	13
Section 25-1.6 Cabs	13
Section 25-1.7 General Requirements	16
Section 25-1.8 Electrical Equipment	17
Section 25-1.9 Instruction Manuals	18
Chapter 25-2 Inspection, Testing, and Maintenance	19
Section 25-2.1 Inspection — General	19
Section 25-2.2 Testing	20
Section 25-2.3 Maintenance	20
Chapter 25-3 Operation	22
Section 25-3.1 Qualifications and Responsibilities	22
Section 25-3.2 Handling the Load	23
Section 25-3.3 Signals	24
Section 25-3.4 Miscellaneous	24
Figures	
25-0.2.1-1 Crawler-Mounted Handler	2
25-0.2.1-2 Pedestal-Mounted Handler	3
25-0.2.1-3 Rail-Mounted Handler	4
25-0.2.1-4 Wheel-Mounted Handler (Multiple Control Stations)	5
25-0.2.1-5 Wheel-Mounted Handler (Single Control Station)	6
25-0.2.2-1 Two-Piece Front	9
25-0.2.2-2 Three-Piece Front	10
25-1.5.2-1 Wheel-Mounted Handler — Primary Travel Control Diagram	14



Track-Mounted Handler — Primary Travel Control Diagram	15
Primary Front Controls — Three-Piece Fronts	15
Primary Front Controls — Two-Piece Fronts	16
Material Handler Hand Signals	26

Tables

25-3.4.10-1	Required Clearance for Normal Voltage in Operation Near High Voltage Power Lines	1
-------------	--	---

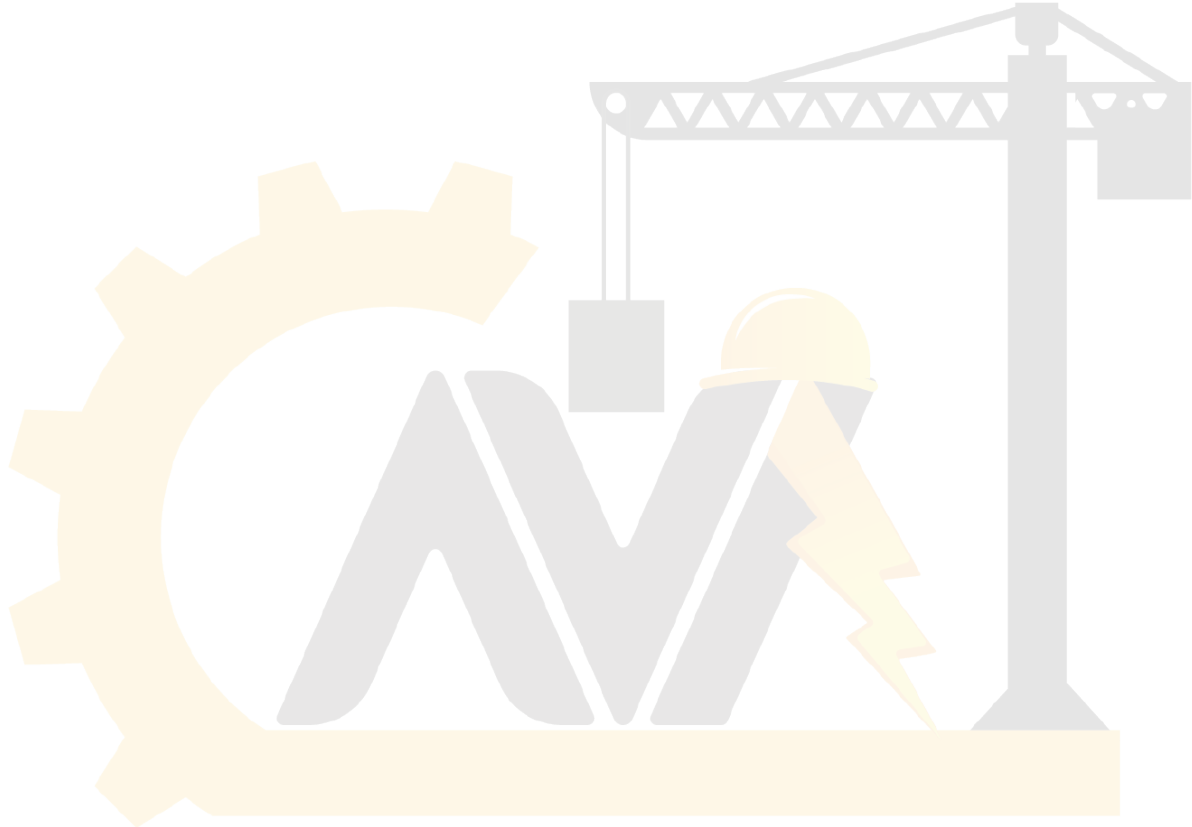

آریا ایمن آوات



FOREWORD

This American National Standard, Safety Standard for Cableways, Cranes, Derricks, Hoists, Hooks, Jacks, and Slings, has been developed under the procedures accredited by the American National Standards Institute (ANSI). This Standard had its beginning in December 1916 when an eight-page “Code of Safety Standards for Cranes,” prepared by an ASME Committee on the Protection of Industrial Workers, was presented at the annual meeting of the ASME.

Meetings and discussions regarding safety on cranes, derricks, and hoists were held from 1920 to 1925, involving the ASME Safety Code Correlating Committee, the Association of Iron and Steel Electrical Engineers, the American Museum of Safety, the American Engineering Standards Committee (AESC) [later changed to American Standards Association (ASA), then to the United States of America Standards Institute (USASI), and finally to ANSI], Department of Labor — State of New Jersey, Department of Labor and Industry — State of Pennsylvania, and the Locomotive Crane Manufacturers Association. On June 11, 1925, AESC approved the ASME Safety Code Correlating Committee’s recommendation and authorized the project with the U.S. Department of the Navy, Bureau of Yards and Docks, and ASME as sponsors.

In March 1926, invitations were issued to 50 organizations to appoint representatives to a Sectional Committee. The call for organization of this Sectional Committee was sent out October 2, 1926, and the committee organized November 4, 1926, with 57 members representing 29 national organizations. Commencing June 1, 1927, and using the eight-page code published by ASME in 1916 as a basis, the Sectional Committee developed the “Safety Code for Cranes, Derricks, and Hoists.” The early drafts of this safety code included requirements for “Jacks” but, due to inputs and comments on those drafts, the Sectional Committee decided in 1938 to make the requirements for jacks a separate code. In January 1943, ASA B30.2-1943 was published addressing a multitude of equipment types, and in August 1943, ASA B30.1-1943 was published just addressing jacks. Both documents were reaffirmed in 1952 and widely accepted as safety standards.

Due to changes in design, advancement in techniques, and general interest of labor and industry in safety, the Sectional Committee, under the joint sponsorship of ASME and the Bureau of Yards and Docks (now the Naval Facilities Engineering Command), was reorganized on January 31, 1962, with 39 members representing 27 national organizations.

The new Committee changed the format of ASA B30.2-1943 so that the multitude of equipment types it addressed could be published in separate volumes that could completely cover the construction, installation, inspection, testing, maintenance, and operation of each type of equipment that was included in the scope of ASA B30.2. This format change resulted in the initial publication of B30.3, B30.5, B30.6, B30.11, and B30.16 being designated as “Revisions” of B30.2 with the remainder of the B30 volumes being published as totally new volumes. ASA changed its name to USASI in 1966 and to ANSI in 1969, which resulted in B30 volumes from 1943 to 1968 being designated as either “ASA B30,” “USAS B30,” or “ANSI B30” depending on their date of publication.

In 1982, the Committee was reorganized as an Accredited Organization Committee, operating under procedures developed by ASME and accredited by ANSI.

This Standard presents a coordinated set of rules that may serve as a guide to government and other regulatory bodies and municipal authorities responsible for the guarding and inspection of the equipment falling within its scope. The suggestions leading to accident prevention are given both as mandatory and advisory provisions; compliance with both types may be required by employers of their employees.

In case of practical difficulties, new developments, or unnecessary hardship, the administrative or regulatory authority may grant variances from the literal requirements or permit the use of other devices or methods, but only when it is clearly evident that an equivalent degree of protection is thereby secured. To secure uniform application and interpretation of this Standard, administrative or regulatory authorities are urged to consult the B30 Committee, in accordance with the format described in [Section IX](#) of the Introduction, before rendering decisions on disputed points.

Safety codes and standards are intended to enhance public safety. Revisions result from committee consideration of factors such as technological advances, new data, and changing environmental and industry needs. Revisions do not imply that previous editions were inadequate.

The first edition of B30.25 was issued in 1998, and new editions were released in 2003 and 2007. The 2013 edition added a section in [Chapter 25-0](#) to define personnel competence, added personnel responsibilities to [Chapter 25-3](#), and included many additional minor revisions throughout. This edition changes some of the nomenclature to better reflect the terminology that is currently used throughout the industries that utilize this equipment. Other minor editorial changes have been made to bring this Volume up to current standards. This Volume of the Standard, which was approved by the B30 Committee and by ASME, was approved by ANSI and designated as an American National Standard on June 8, 2018.



ASME B30 COMMITTEE

Safety Standard for Cableways, Cranes, Derricks, Hoists, Hooks, Jacks, and Slings

(The following is the roster of the Committee at the time of approval of this Standard.)

STANDARDS COMMITTEE OFFICERS

T. L. Blanton, *Chair*
E. D. Fidler, *Vice Chair*
K. M. Hyam, *Secretary*

STANDARDS COMMITTEE PERSONNEL

N. E. Andrew, LTS Crane Mechanical
T. L. Blanton, NACB Group, Inc.
P. A. Boeckman, The Crosby Group, Inc.
P. W. Boyd, The Boeing Co.
B. D. Closson, Craft Forensic Services
J. A. Danielson, The Boeing Co.
D. R. Decker, Becket, LLC
L. D. Demark, Sr., Equipment Training Solutions, LLC
D. W. Eckstine, Eckstine & Associates
R. J. Edwards, NationsBuilders Insurance Services, Inc.
A. J. Egging, National Oilwell Varco
E. D. Fidler, Grove U.S., LLC
J. A. Gilbert, Associated Wire Rope Fabricators
J. L. Gordon, Acco Material Handling Solutions, Inc.
N. C. Hargreaves, Consultant
G. B. Hetherston, Consultant
K. M. Hyam, The American Society of Mechanical Engineers
M. M. Jaxtheimer, Navy Crane Center
P. R. Juhren, Morrow Equipment Co., LLC
R. M. Kohner, Landmark Engineering Services
A. J. Lusi, Jr., Lumark Consulting, LLP
E. K. Marburg, Columbus McKinnon Corp.
L. D. Means, Means Engineering & Consulting
M. W. Mills, Liberty Mutual Insurance
D. L. Morgan, Critical Lift Consultants, LLC
W. E. Osborn, Ingersoll Rand
R. M. Parnell, ITI — Field Service
J. T. Perkins, First Solar Electric
B. A. Pickett, Systems Engineering and Forensic Services
J. A. Pilgrim, Manitowoc Cranes
S. K. Rammelsberg, CB&I
J. E. Richardson, U.S. Department of the Navy
D. W. Ritchie, Dave Ritchie Consultant, LLC
J. W. Rowland III, Consultant
J. C. Ryan, Boh Bros. Construction Co.
D. W. Smith, STI Group
W. J. Smith, Jr., NationsBuilders Insurance Services, Inc.
R. S. Stemp, Lampson International, LLC
R. G. Strain, Advanced Crane Technologies, LLC
J. Sturm, Sturm Corp.
P. D. Sweeney, Riverside Engineering, LLC
E. P. Vliet, Consultant
J. D. Wiethorn, Haag Engineering Co.
R. C. Wild, CJ Drilling, Inc.
D. N. Wolff, National Crane/Manitowoc Crane Group
S. D. Wood, Terex Corp.
B. B. Bacon, *Alternate*, Tennessee Valley Authority
R. J. Bolen, *Alternate*, Consultant
G. J. Brent, *Alternate*, NCCCO
J. R. Burkey, *Alternate*, Columbus McKinnon Corp.
B. M. Casey, *Alternate*, Electric Boat
W. C. Dickinson, Jr., *Alternate*, Crane Industry Services, LLC
J. Dudley, *Alternate*, The Walsh Group
D. Duerr, *Alternate*, 2DM Associates, Inc.
M. Eggenberger, *Alternate*, Berry Contracting, Inc.
S. R. Fletcher, *Alternate*, Cowles, Murphy, Glover & Associates
M. Gardiner, *Alternate*, Haag Engineering Co.
S. R. Gridley, *Alternate*, Navy Crane Center
D. A. Henninger, *Alternate*, Bridon Bekaert, The Ropes Group
D. F. Jordan, *Alternate*, American International Crane Bureau
K. Kennedy, *Alternate*, Navy Crane Center
J. Lindsay, *Alternate*, Link-Belt Construction Equipment
T. C. Mackey, *Alternate*, WRPS Hanford, an AECOM Co.
J. P. Muhlbauer, *Alternate*, All Ship & Cargo Surveys, Ltd.
D. A. Moore, *Alternate*, Unified Engineering
L. S. Olver, *Alternate*, Kolo Holdings, Inc.
J. M. Randall, *Alternate*, CB&I
K. Rask, *Alternate*, NationsBuilders Insurance Services, Inc.
C. L. Richardson, *Alternate*, Lone Star Rigging, LP
A. R. Ruud, *Alternate*, Atkinson Construction
J. R. Schober, *Alternate*, American Bridge Co.
J. Schoppert, *Alternate*, NBIS Claims & Risk Management
L. K. Shapiro, *Alternate*, Howard I. Shapiro & Associates
K. Shinn, *Alternate*, K. J. Shinn, Inc.
C. H. Smith, *Alternate*, Morrow Equipment Co., LLC
S. Snider, *Alternate*, Ingersoll Rand
R. Stanoch, *Alternate*, IPS Cranes
C. Warren, *Alternate*, Webber, LLC
A. T. West, *Alternate*, Liberty Mutual Insurance
M. P. Zerba, *Alternate*, Lampson International, LLC



HONORARY MEMBERS

J. W. Downs, Jr., Downs Crane and Hoist Co.
J. L. Franks, Consultant
J. M. Klibert, Lift-All Co., Inc.

R. W. Parry, Consultant
P. S. Zorich, RZP International Ltd.

B30 INTEREST REVIEW GROUP

O. Akinboboye, Ropetech Engineering Services
D. Beltran, Gunnebo Johnson Corp.
J. D. Cannon, U.S. Army Corps of Engineers
B. Dobbs, LEEA
M. J. Eggenberger, Berry Contracting, Inc.
A. Gomes Rocha, Belgo Bekaert Arames
H. A. Hashem, Saudi Aramco
J. Hui, Si Pai Lou, School of Civil Engineering

C. Lan, Department of Industry — BSEE
A. C. Mattoli, Prowinch, LLC
J. P. Mihlbauer, All Ship & Cargo Surveys, Ltd.
L. S. Olver, Kolo Holdings, Inc.
G. L. Owens, Consultant
D. R. Remus, Reed Manufacturing
C. C. Tsauro, Institute of Occupational Safety and Health

B30 REGULATORY AUTHORITY COUNCIL

C. Shelhamer, *Chair*, New York City Department of Buildings
K. M. Hyam, *Secretary*, The American Society of Mechanical Engineers
L. G. Campion, Department of Labor/OSHA
R. Feidt, Stephenson Equipment, Inc.
C. Harris, City of Chicago — Department of Buildings
R. D. Jackson, U.S. Department of Labor
J. L. Lankford, State of Nevada (OSHA)
D. E. Latham, State of Maryland DLLR
A. Lundeen, State of Washington, Department of Labor and Industries

J. Mendoza, North Carolina Department of Labor, Division of Occupational Safety
M. J. Nelmda, State of California, Occupational Safety and Health Standards Board
G. E. Pushies, MIOSHA
C. N. Stribling, Jr., Kentucky Labor Cabinet
T. Taylor, Minnesota Department of Labor & Industry
A. O. Omran, *Alternate*, New York City Department of Buildings
K. L. Powell, *Alternate*, Maryland Department of Labor, MOSH

B30.25 SUBCOMMITTEE PERSONNEL

A. R. Smith, *Chair*, Institute of Scrap Recycling Industries, Inc.
T. A. Cannegieter, Volvo Construction Equipment
C. M. Crowell, Caterpillar, Inc.
D. Engels, Sennebogen LLC USA
P. D. Gage, TMS International, LLC
S. N. Jacoby, Schnitzer Steel

K. M. Jankowski, Walker Magnetics
M. W. Osborne, E-Crane International USA
M. A. Rangos, Liebherr Construction Equipment Co.
B. A. Selack, LBX Co., LLC
J. F. Soderlind, Young Corp.

آریا ایمن آوات

B30 STANDARD INTRODUCTION

SECTION I: SCOPE

The ASME B30 Standard contains provisions that apply to the construction, installation, operation, inspection, testing, maintenance, and use of cranes and other lifting and material-movement-related equipment. For the convenience of the reader, the Standard has been divided into separate volumes. Each volume has been written under the direction of the ASME B30 Standards Committee and has successfully completed a consensus approval process under the general auspices of the American National Standards Institute (ANSI).

As of the date of issuance of this Volume, the B30 Standard comprises the following volumes:

- B30.1 Jacks, Industrial Rollers, Air Casters, and Hydraulic Gantries
- B30.2 Overhead and Gantry Cranes (Top Running Bridge, Single or Multiple Girder, Top Running Trolley Hoist)
- B30.3 Tower Cranes
- B30.4 Portal and Pedestal Cranes
- B30.5 Mobile and Locomotive Cranes
- B30.6 Derricks
- B30.7 Winches
- B30.8 Floating Cranes and Floating Derricks
- B30.9 Slings
- B30.10 Hooks
- B30.11 Monorails and Underhung Cranes (withdrawn 2018 — requirements found in latest revision of B30.17)
- B30.12 Handling Loads Suspended From Rotorcraft
- B30.13 Storage/Retrieval (S/R) Machines and Associated Equipment
- B30.14 Side Boom Tractors
- B30.15 Mobile Hydraulic Cranes (withdrawn 1982 — requirements found in latest revision of B30.5)
- B30.16 Overhead Underhung and Stationary Hoists
- B30.17 Cranes and Monorails (With Underhung Trolley or Bridge)
- B30.18 Stacker Cranes (Top or Under Running Bridge, Multiple Girder With Top or Under Running Trolley Hoist)
- B30.19 Cableways

- B30.20 Below-the-Hook Lifting Devices
- B30.21 Lever Hoists
- B30.22 Articulating Boom Cranes
- B30.23 Personnel Lifting Systems
- B30.24 Container Cranes
- B30.25 Scrap and Material Handlers
- B30.26 Rigging Hardware
- B30.27 Material Placement Systems
- B30.28 Balance Lifting Units
- B30.29 Self-Erecting Tower Cranes
- B30.30 Ropes¹
- B30.31 Self-Propelled, Towed, or Remote-Controlled Hydraulic Platform Transporters¹
- B30.32 Unmanned Aircraft Systems (UAS) Used in Inspection, Testing, Maintenance, and Lifting Operations¹

SECTION II: SCOPE EXCLUSIONS

Any exclusion of, or limitations applicable to, the equipment, requirements, recommendations, or operations contained in this Standard are established in the affected volume's scope.

SECTION III: PURPOSE

The B30 Standard is intended to

- (a) prevent or minimize injury to workers, and otherwise provide for the protection of life, limb, and property by prescribing safety requirements
- (b) provide direction to manufacturers, owners, employers, users, and others concerned with, or responsible for, its application
- (c) guide governments and other regulatory bodies in the development, promulgation, and enforcement of appropriate safety directives

SECTION IV: USE BY REGULATORY AGENCIES

These volumes may be adopted in whole or in part for governmental or regulatory use. If adopted for governmental use, the references to other national codes and standards in the specific volumes may be changed to refer to the corresponding regulations of the governmental authorities.

¹This volume is currently in the development process.



V: EFFECTIVE DATE

Effective Date. The effective date of this Volume of the B30 Standard shall be 1 yr after its date of issuance. Construction, installation, inspection, testing, maintenance, and operation of equipment manufactured and facilities constructed after the effective date of this Volume shall conform to the mandatory requirements of this Volume.

(b) *Existing Installations.* Equipment manufactured and facilities constructed prior to the effective date of this Volume of the B30 Standard shall be subject to the inspection, testing, maintenance, and operation requirements of this Standard after the effective date.

It is not the intent of this Volume of the B30 Standard to require retrofitting of existing equipment. However, when an item is being modified, its performance requirements shall be reviewed relative to the requirements within the current volume. The need to meet the current requirements shall be evaluated by a qualified person selected by the owner (user). Recommended changes shall be made by the owner (user) within 1 yr.

SECTION VI: REQUIREMENTS AND RECOMMENDATIONS

Requirements of this Standard are characterized by use of the word *shall*. Recommendations of this Standard are characterized by the word *should*.

SECTION VII: USE OF MEASUREMENT UNITS

This Standard contains SI (metric) units as well as U.S. Customary units. The values stated in U.S. Customary units are to be regarded as the standard. The SI units are a direct (soft) conversion from the U.S. Customary units.

SECTION VIII: REQUESTS FOR REVISION

The B30 Standards Committee will consider requests for revision of any of the volumes within the B30 Standard. Such requests should be directed to

Secretary, B30 Standards Committee
ASME Codes and Standards
Two Park Avenue
New York, NY 10016-5990

Requests should be in the following format:

Volume: Cite the designation and title of the volume.
Edition: Cite the applicable edition of the volume.
Subject: Cite the applicable paragraph number(s) and the relevant heading(s).
Request: Indicate the suggested revision.
Rationale: State the rationale for the suggested revision.

Upon receipt by the Secretary, the request will be forwarded to the relevant B30 Subcommittee for consideration and action. Correspondence will be provided to the requester defining the actions undertaken by the B30 Standards Committee.

SECTION IX: REQUESTS FOR INTERPRETATION

The B30 Standards Committee will render an interpretation of the provisions of the B30 Standard. An Interpretation Submittal Form is available on ASME's website at <http://cstools.asme.org/Interpretation/InterpretationForm.cfm>.

Phrase the question as a request for an interpretation of a specific provision suitable for general understanding and use, not as a request for approval of a proprietary design or situation. Plans or drawings that explain the question may be submitted to clarify the question. However, they should not contain any proprietary names or information. Read carefully the note addressing the types of requests that the B30 Standards Committee can and cannot consider.

Upon submittal, the request will be forwarded to the relevant B30 Subcommittee for a draft response, which will then be subject to approval by the B30 Standards Committee prior to its formal issuance. The B30 Standards Committee may rewrite the question for the sake of clarity.

Interpretations to the B30 Standard will be available online at <https://cstools.asme.org/Interpretation/SearchInterpretation.cfm>.

SECTION X: ADDITIONAL GUIDANCE

The equipment covered by the B30 Standard is subject to hazards that cannot be abated by mechanical means, but only by the exercise of intelligence, care, and common sense. It is therefore essential to have personnel involved in the use and operation of equipment who are competent, careful, physically and mentally qualified, and trained in the proper operation of the equipment and the handling of loads. Serious hazards include, but are not limited to, improper or inadequate maintenance, overloading, dropping or slipping of the load, obstructing the free passage of the load, and using equipment for a purpose for which it was not intended or designed.

The B30 Standards Committee fully realizes the importance of proper design factors, minimum or maximum dimensions, and other limiting criteria of wire rope or chain and their fastenings, sheaves, sprockets, drums, and similar equipment covered by the Standard, all of which are closely connected with safety. Sizes, strengths, and similar criteria are dependent on many different factors, often varying with the installation and uses. These factors depend on

- (a) the condition of the equipment or material
- (b) the loads



آریا ایمن آوات

eleration or speed of the ropes, chains, sockets, or drums
type of attachments

(e) the number, size, and arrangement of sheaves or other parts

(f) environmental conditions causing corrosion or wear

(g) many variables that must be considered in each individual case

The requirements and recommendations provided in the volumes must be interpreted accordingly, and judgment used in determining their application.

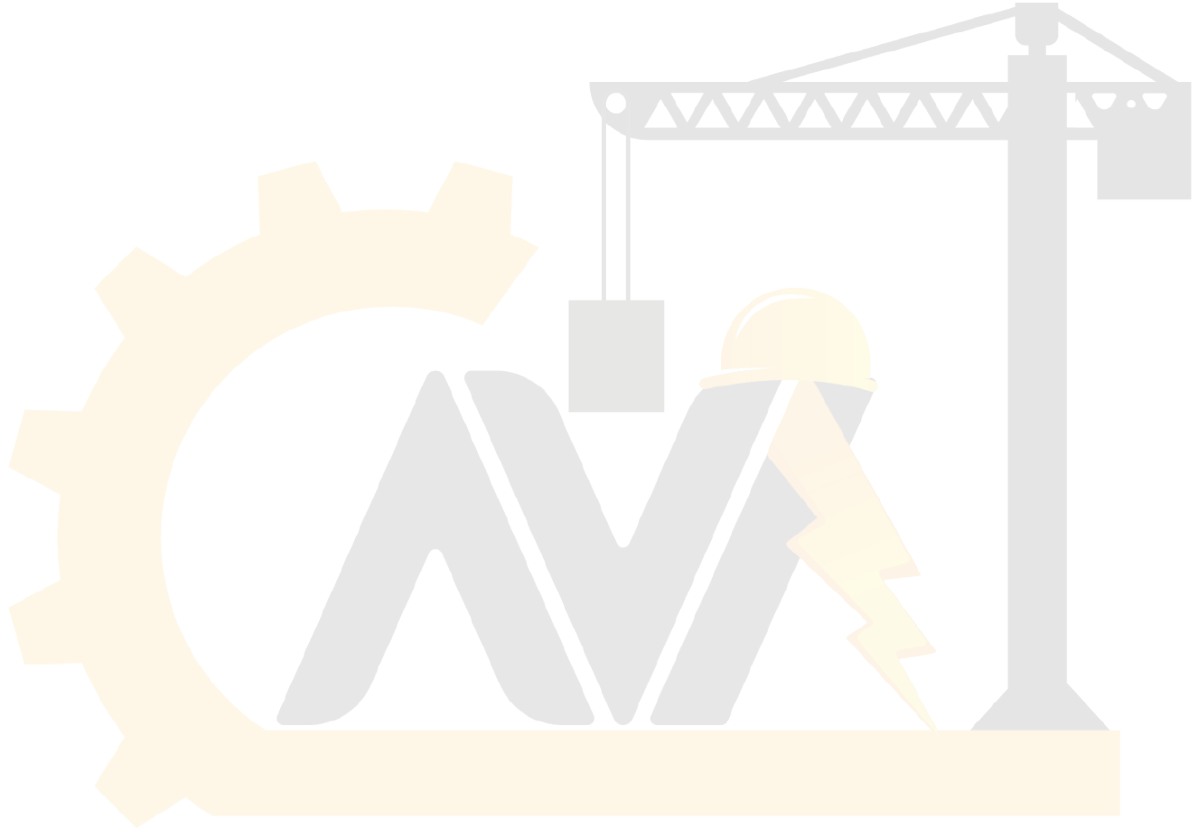

آریا ایمن آوات

ASME B30.25-2018 SUMMARY OF CHANGES

Following approval by the ASME B30 Committee and ASME, and after public review, ASME B30.25-2018 was approved by the American National Standards Institute on June 8, 2018.

ASME B30.25-2018 includes the following changes identified by a margin note, **(18)**.

<i>Page</i>	<i>Location</i>	<i>Change</i>
viii	B30 Standard Introduction	Revised
1	25-0.2.2	(1) Definitions of <i>arm (stick)</i> and <i>arm cylinder(s)</i> deleted (2) Definitions of <i>jib, jib cylinder(s)</i> , and <i>three points of support</i> revised (3) Definitions of <i>shall, should, stick</i> , and <i>stick cylinder(s)</i> added
7	25-0.4	References updated
9	Figure 25-0.2.2-1	Callout revised
10	Figure 25-0.2.2-2	Callout revised
13	25-1.5.3	Subparagraph (a) revised
14	Figure 25-1.5.2-1	Editorially redesignated
15	Figure 25-1.5.2-2	Editorially redesignated
15	Figure 25-1.5.3-1	(1) Editorially redesignated (2) Callout revised
16	Figure 25-1.5.3-2	(1) Editorially redesignated (2) Callout revised
16	25-1.6.4	Subparagraph (c)(2) revised
17	25-1.7.3	Subparagraph (b) revised
17	25-1.7.4	Subparagraph (c) deleted
19	25-2.1.2	First paragraph revised
19	25-2.1.3	First paragraph revised
24	25-3.2.3	Subparagraph (h) revised
25	25-3.4.6	Revised
25	25-3.4.8	Subparagraph (a) revised
26	Figure 25-3.3.2-1	Callout revised



آریا ایمن آوات

Chapter 25-0

Scope, Definitions, Personnel Competence, and References

SECTION 25-0.1: SCOPE OF B30.25

Volume B30.25 includes provisions that apply to the construction, installation, operation, inspection, and maintenance of scrap and material handlers consisting of a base, a revolving upper structure with operator's station(s), and a front for lifting scrap or materials using attachments such as magnets and grapples, and any variations thereof in which the equipment retains the same fundamental characteristics. The provisions included in this Volume apply to scrap and material handlers that are crawler mounted, rail mounted, wheel mounted, or on pedestal bases. The scope includes hydraulically operated scrap and material handlers powered by internal combustion engines or electric motors to lift, lower, and swing scrap and material at various radii.

Hydraulic excavators designed for digging and trenching, forestry machines, machines designed for demolition, lattice and telescopic boom cranes, rail-mounted cranes for railway and automobile wreck clearance, and equipment covered by other volumes of this Standard are excluded.

SECTION 25-0.2: DEFINITIONS

25-0.2.1 Types of Scrap and Material Handlers

A scrap and material handler is herein after referred to as a "handler." Handlers may be mounted on one of the following bases:

crawler handler: mounted on a base, equipped with crawler tracks for travel (see Figure 25-0.2.1-1).

pedestal-mounted handler: mounted on a pedestal base (see Figure 25-0.2.1-2).

rail-mounted handler: mounted on a base, equipped for travel on a railroad track (see Figure 25-0.2.1-3).

wheel-mounted handler (multiple control stations): mounted on a base, equipped with axles and rubber-tired wheels for travel, a power source(s), and having separate control stations for driving and operating (see Figure 25-0.2.1-4).

wheel-mounted handler (single control station): mounted on a base, equipped with axles and rubber-tired wheels for travel, a power source, and having a single control station for driving and operating (see Figure 25-0.2.1-5).

25-0.2.2 General

(18)

accessory: a secondary part or assembly of parts that contributes to the overall function and usefulness of a machine.

administrative or regulatory authority: a governmental agency, or the employer in the absence of governmental jurisdiction.

ancillary equipment: equipment not required for the basic operation of the handler.

assembler/modifier: entity that assembles and/or modifies basic components to produce a handler.

attachment: an accessory like a magnet or grapple that is affixed to the second or third member of a front.

axis of rotation: the vertical axis around which the handler upper-structure rotates.

axle: the shaft or spindle with which or about which a wheel rotates. On wheel-mounted handlers it refers to a type of axle assembly including housings, gearing, differential, bearings, and mounting appurtenances.

axle (bogie): two or more axles mounted in tandem in a frame so as to divide the load between the axles and permit vertical oscillation of the wheels.

backward stability: the handler's ability to resist overturning in the direction opposite the front while in the unloaded condition.

ballast: weight used to supplement the weight of the handler in providing stability for handling loads (the term "ballast" is normally associated with rail-mounted handlers).

base (mounting): the structure on which the rotating upper-structure handler is mounted.

boom: first section of a front, one end of which is attached to the upper-structure.

boom cylinder(s): the hydraulic cylinder(s) that move(s) the boom vertically in relation to the upper-structure.

brake: a device used for retarding or stopping motion.

brake, parking: a system to prevent inadvertent movement of a stationary handler.

brake, secondary: a system for stopping the handler upon service brake system failure.

brake, service: a system for slowing and stopping the handler during travel operation.

Figure 25-0.2.1-1 Crawler-Mounted Handler

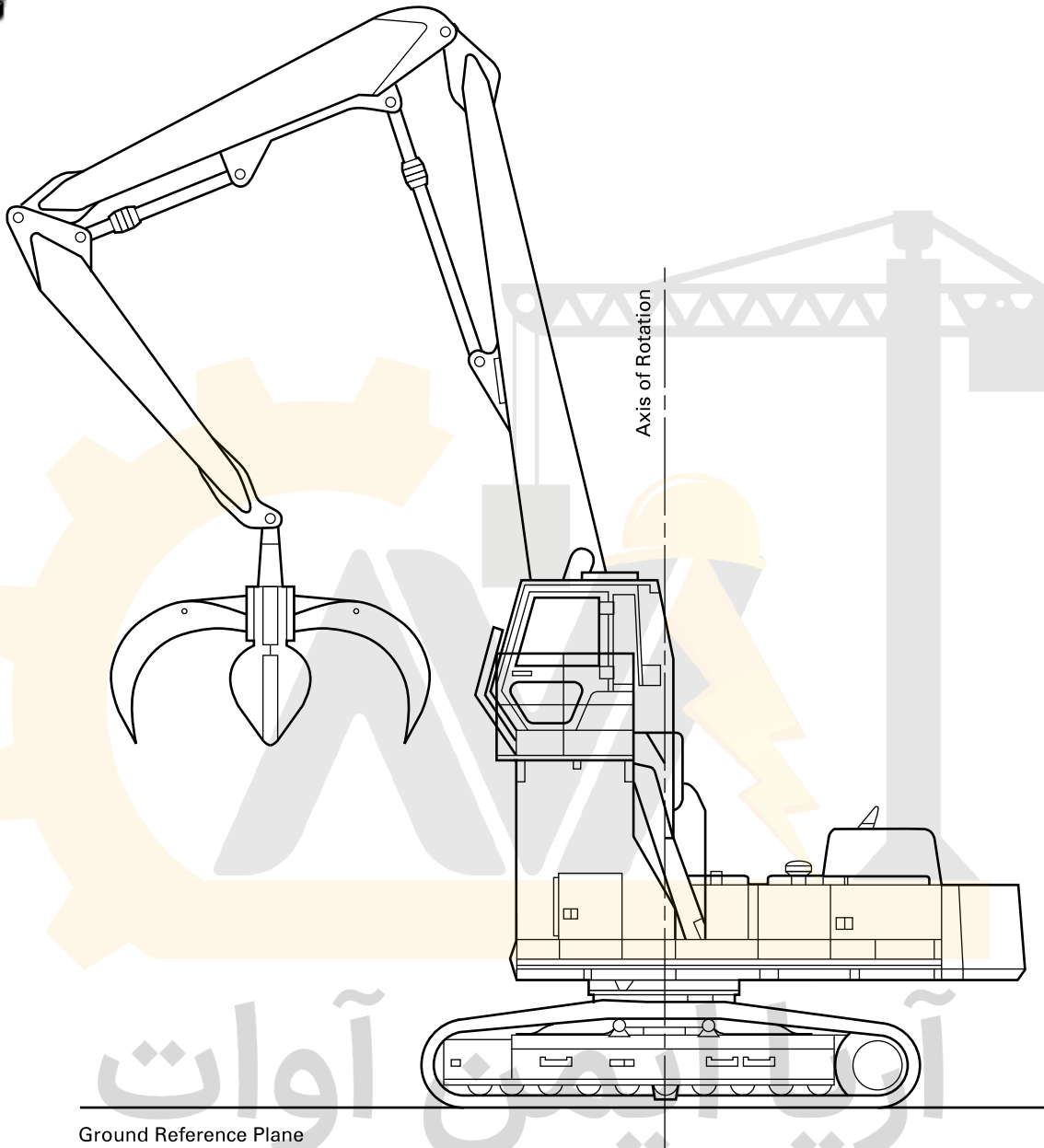

Figure 25-0.2.1-2 Pedestal-Mounted Handler

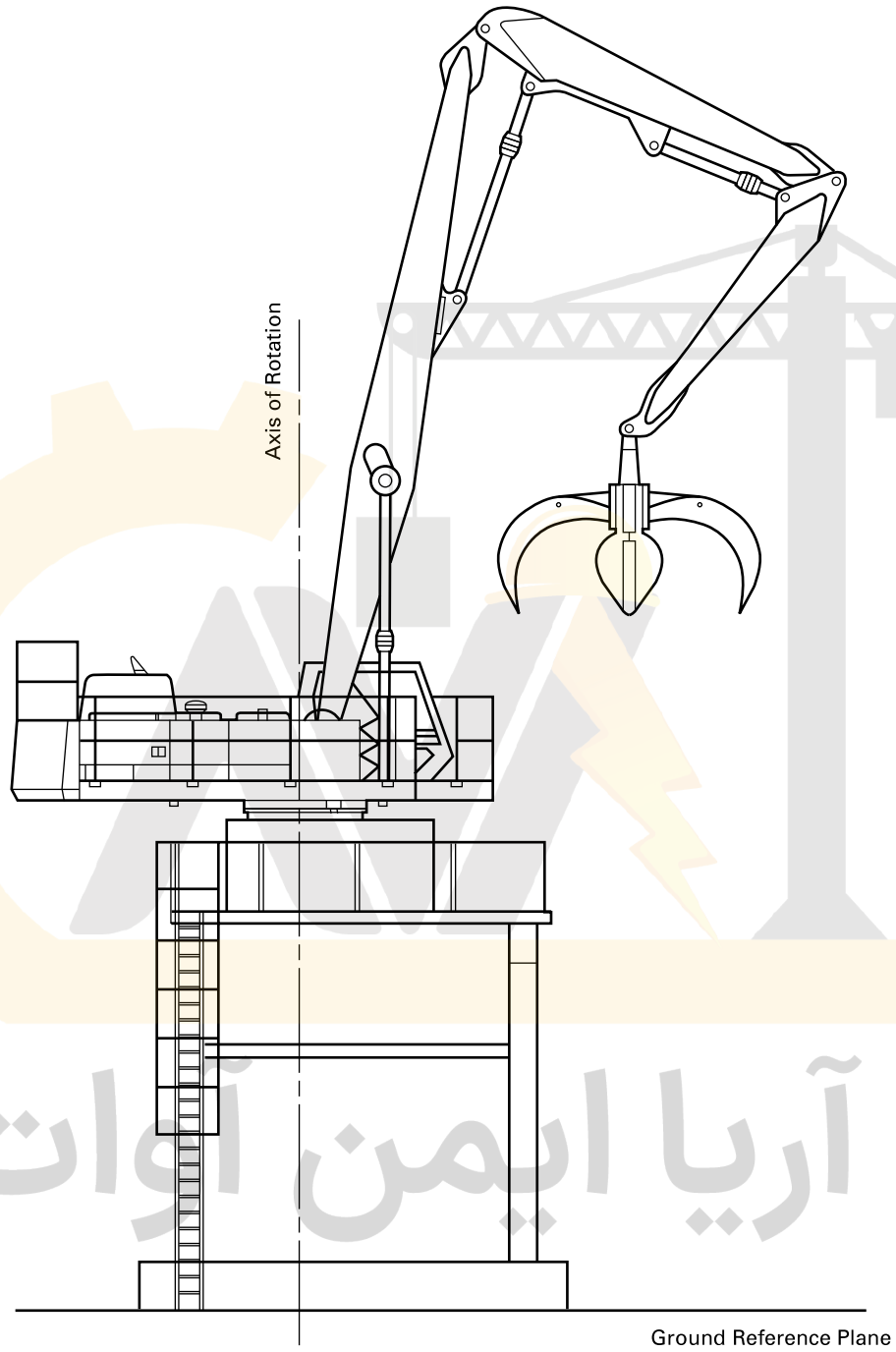
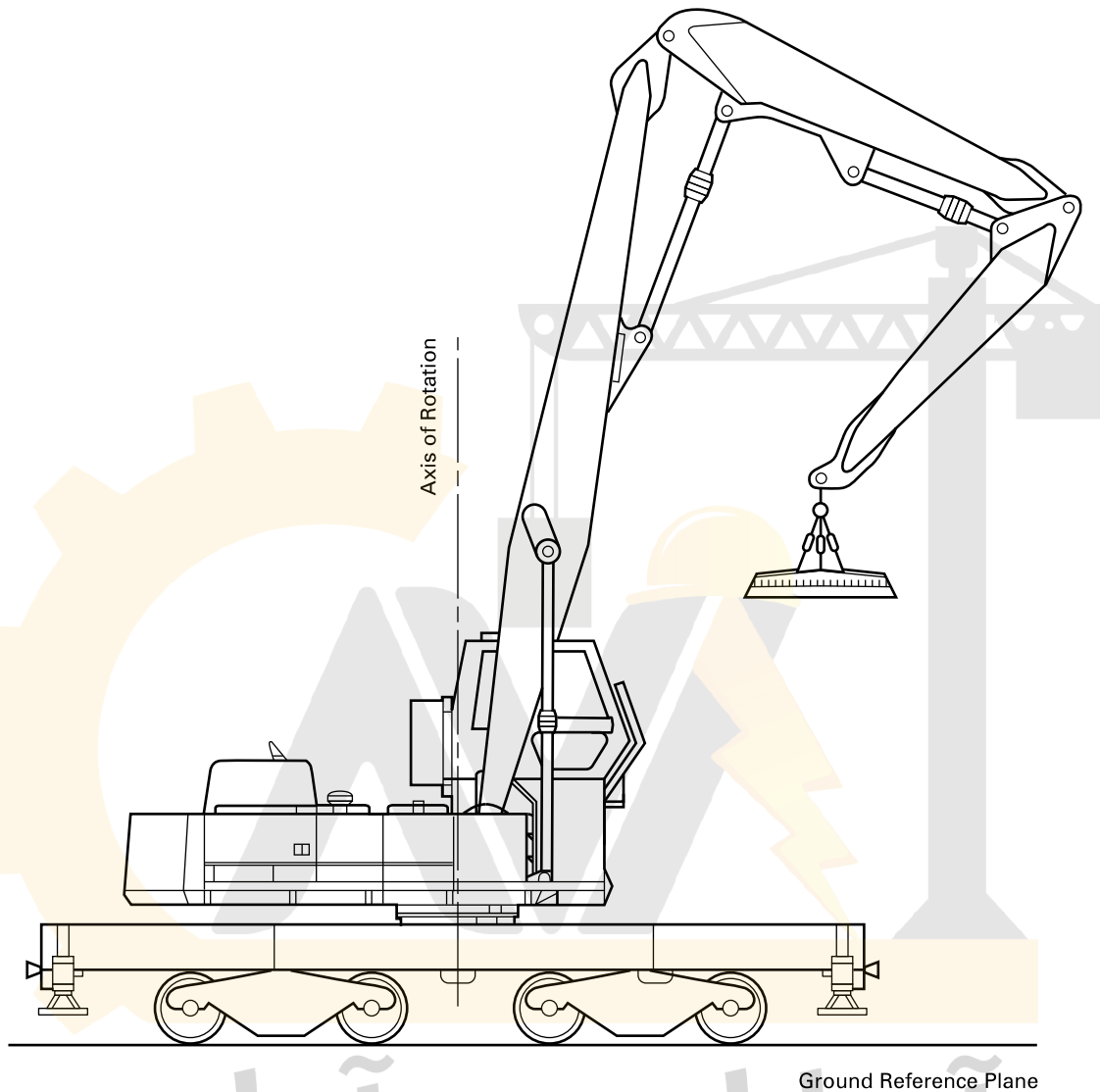

Figure 25-0.2.1-3 Rail-Mounted Handler



cab: a weatherproof housing that covers the operator's station.

counterweight: weight used to supplement the weight of the handler in providing stability for handling loads.

daily: a work shift consisting of a period of 10 hr or less usage within a 24-hr period.

front: consists of two or three structural members actuated by hydraulic cylinders that are affixed to the upper-structure for mounting the attachment (see [Figures 25-0.2.2-1](#) and [25-0.2.2-2](#)).

jib: third section of a front, one end of which is attached to the stick.

jib cylinder(s): the hydraulic cylinder(s) that move(s) the jib in relation to the stick.

lift capacity: ratings in pounds (kilograms) established by the manufacturer or assembler/modifier.

manufacturer: the entity that designs, fabricates, and assembles basic components.

material: waste products processed for incineration and/or disposal.

monthly: a period of 200 hr or less usage within a 30-day period.

outriggers: extendable or fixed members attached to the mounting base that are used to raise, level, and support the handler.

qualified operator: an operator who has met the requirements of this Volume and has been appointed as an operator.

Figure 25-0.2.1-4 Wheel-Mounted Handler (Multiple Control Stations)

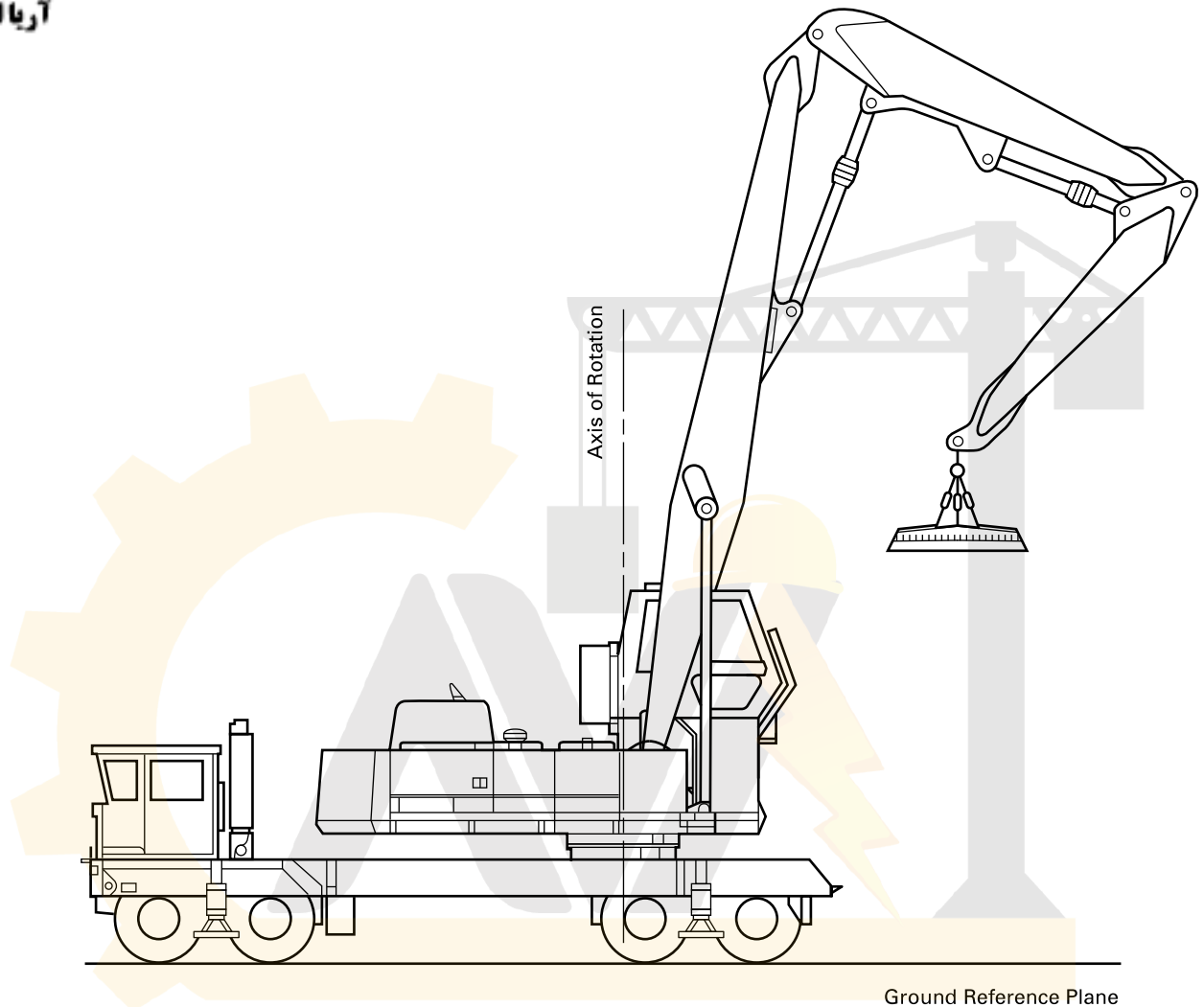

qualified person: a person who, by possession of a recognized degree in an applicable field, or certificate of professional standing, or who, by extensive knowledge, training, and experience, has successfully demonstrated the ability to solve or resolve problems relating to the subject matter and work.

rail clamp: a tong-like metal device mounted on a locomotive car, which can be connected to the track to prevent movement along the rail.

safety sign: a visual alerting device in the form of a decal, label, placard, or other marking that advises the operator or others of the nature and the degree of the potential hazard(s). It can also describe safety precautions or evasive actions to take, or provide other directions to eliminate or reduce the hazard (ANSI Z535.4-2011).

scrap: metals, paper, plastic, glass, rubber, or textiles that are diverted, collected, sorted, shredded, sheared, baled, chipped, separated, sized, or otherwise processed for use in making new products.

shall: a word indicating a requirement.

should: a word indicating a recommendation.

side loading: a nonvertical load applied to the vertical plane of the front.

stabilizer: extendable members attached to the mounting base to increase the stability of the rail-mounted handler, but that may not have the capability of relieving all of the weight from the tracks.

stick: the second section of a front, one end of which is attached to the boom.

stick cylinder(s): the hydraulic cylinder(s) that moves the stick in relation to the boom.

Figure 25-0.2.1-5 Wheel-Mounted Handler (Single Control Station)

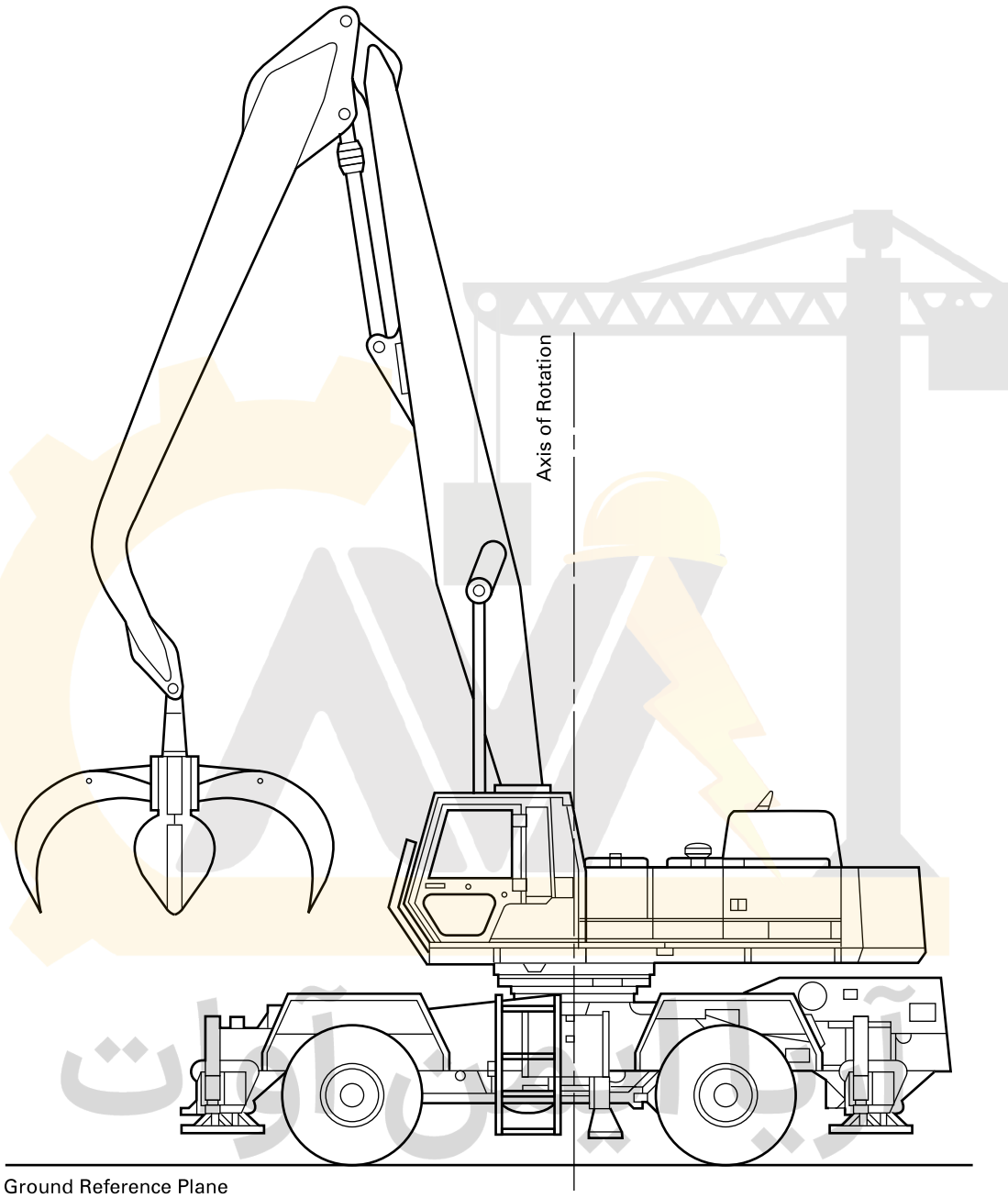



competence: the ability of the handler and its elements to withstand the stresses imposed by the loads.

swing: rotation of the upper structure for movement of loads in a horizontal direction about the axis of rotation.

swing lock: a positive mechanism that prevents rotation of the upper structure.

swing mechanism: the machinery involved in providing rotation of the upper-structure.

three points of support: features of an access system that permits a person to use two hands and one foot, or two feet and one hand (three points of contact) while ascending, descending, or moving about on the handler.

travel: the movement of the handler under its own power from one location to another.

upper-structure: the rotating frame structure of the handler and the operating machinery mounted thereon.

wheel base: the distance between centers of front and rear axles. For a multiple-axle assembly, the axle center for wheel base measurement is taken as the midpoint of the assembly.

SECTION 25-0.3: PERSONNEL COMPETENCE

Persons performing the functions identified in this Volume shall meet the applicable qualifying criteria stated in this Volume and shall, through education, training, experience, skill, and physical fitness, as necessary, be competent and capable to perform the functions as determined by the employer or employer's representative.

(18) SECTION 25-0.4: REFERENCES

The following is a list of standards and specifications referenced in this Standard, showing the year of approval.

ANSI/AWS D14.3-2010, Specification for Welding Earthmoving, Construction, and Agricultural Equipment

Publisher: American Welding Society (AWS), 8669 NW 36 Street, No. 130, Miami, FL 33166 (www.aws.org)

ASME B30.20-2013, Below-the-Hook Lifting Devices

Publisher: The American Society of Mechanical Engineers (ASME), Two Park Avenue, New York, NY 10016-5990 (www.asme.org)

ISO 2860:1992, Earth-moving machinery — Minimum access dimensions

ISO 2867:2011, Earth-moving machinery — Access systems

ISO 3450:2011, Earth-moving machinery — Wheeled or high-speed rubber-tracked machines — Performance requirements and test procedures for brake systems

ISO 3795:1989, Road vehicles, and tractors and machinery for agriculture and forestry — Determination of burning behavior of interior materials

ISO 6405-1:2017 – Part 1: Common symbols

ISO 6405-2:2017 – Part 2: Specific symbols for machines, equipment and accessories

ISO 6682:1986, Earth-moving machinery — Zones of comfort and reach for controls

ISO 6683:2005, Earth-moving machinery — Seat belts and seat belt anchorages — Performance requirements and tests

ISO 7000:2014, Graphical symbols for use on equipment — Registered symbols

ISO 7296-1:1991, Cranes — Graphic symbols — Part 1: General

ISO 9533:2010, Earth-moving machinery — Machine-mounted audible travel alarms and forward horns — Test methods and performance criteria

ISO 10262:1998 (with cor1 2009), Earth-moving machinery — Hydraulic excavators — Laboratory tests and performance requirements for operator protective guards

ISO 10265:2008, Earth-moving machinery — Crawler machines — Performance requirements and test procedures for braking systems

ISO 10968:2004, Earth-moving machinery — Operator's controls

Publisher: International Organization for Standardization (ISO), Central Secretariat, Chemin de Blandonnet 8, Case Postale 401, 1214 Vernier, Geneva, Switzerland (www.iso.org)

ANSI Z535.4-2011 (R2017), Product Safety Signs and Labels

Publisher: National Electrical Manufacturers Association (NEMA), 1300 North 17th Street, Suite 900, Arlington, VA 22209 (www.nema.org)

NFPA 70-2017, National Electrical Code

Publisher: National Fire Protection Association (NFPA), 1 Batterymarch Park, Quincy, MA 02169-7471 (www.nfpa.org)

ANSI Z26.1-1996, Safety Glazing Materials for Glazing Motor Vehicles and Motor Vehicle Equipment Operating on Land Highways — Safety Code

SAE J386:2012, Operator Restraint System for Off-Road Work Machines

SAE J1309:2012, Travel Performance and Rating Procedure, Crawler Mounted Hydraulic Excavators, Material Handlers, Knuckle Boom Log Loaders, and Certain Forestry Equipment

SAE J2518:2012, Lift Capacity Calculation Method, Scrap and Material Handlers

Publisher: SAE International, 400 Commonwealth Drive, Warrendale, PA 15096 (www.sae.org)



ASME B30.25-2018

Safety Appliance Standards and Power
Requirements (January 1973), Revised
October 1977, Federal Railroad Administration,
D.O.T. Standards — U.S. Department of Transportation

Publisher: Superintendent of Documents, U.S.
Government Printing Office (GPO), 732 N. Capitol
Street, NW, Washington, DC 20401 (www.gpo.gov)

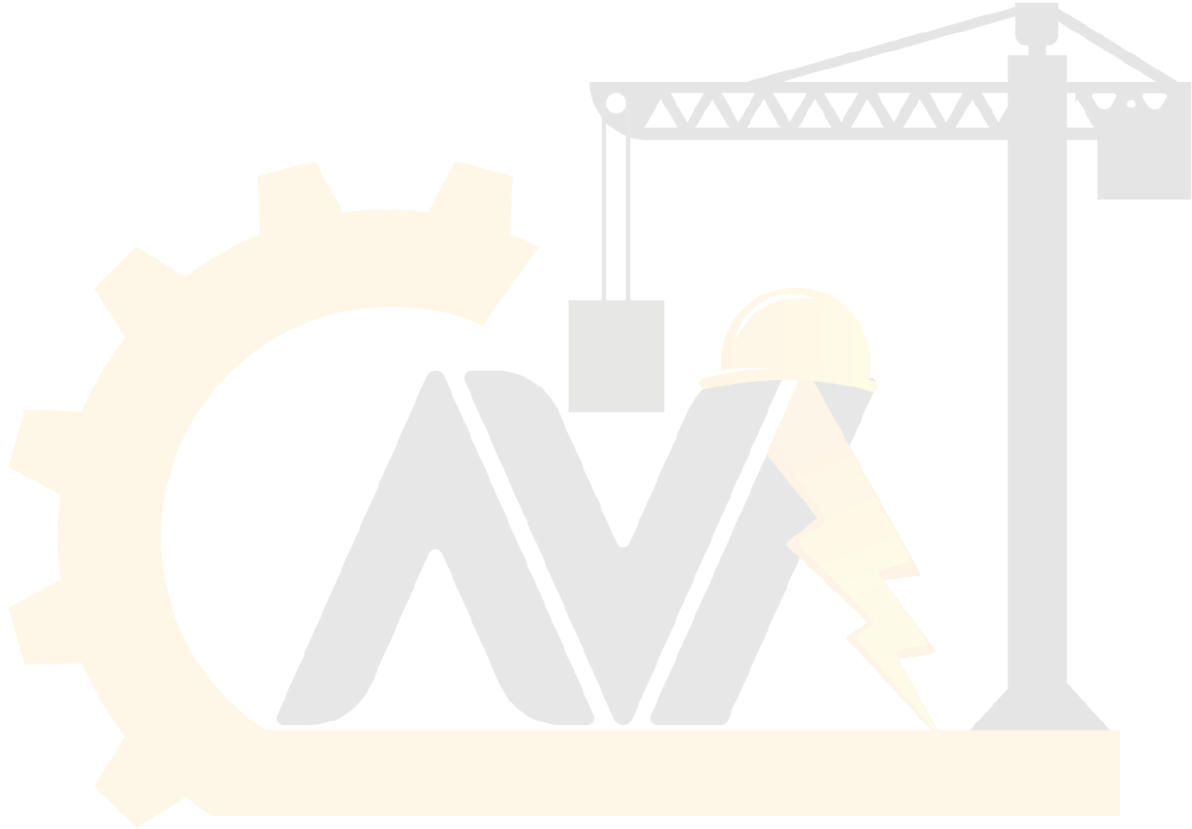

آریا ایمن آوات

Figure 25-0.2.2-1 Two-Piece Front

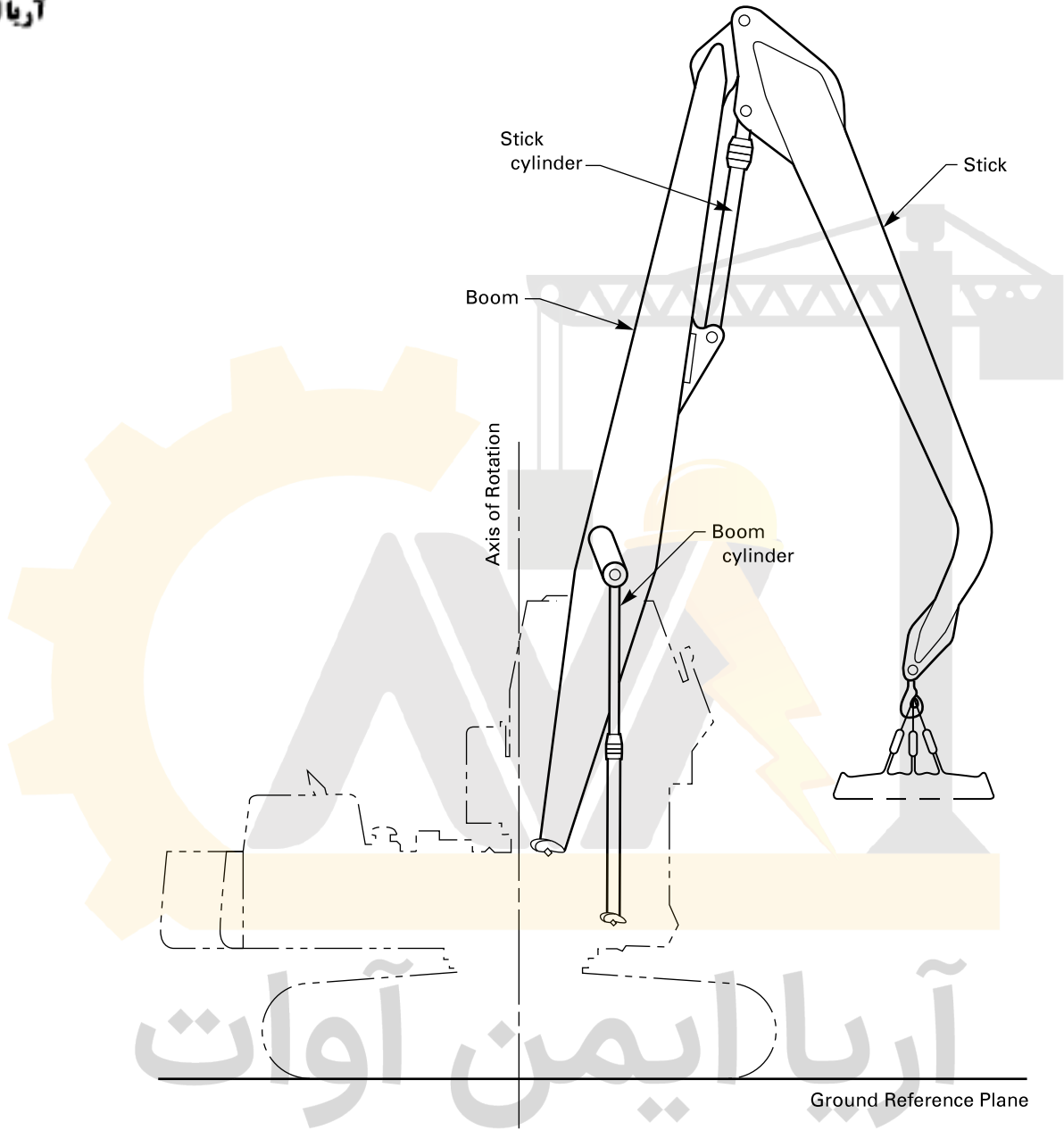
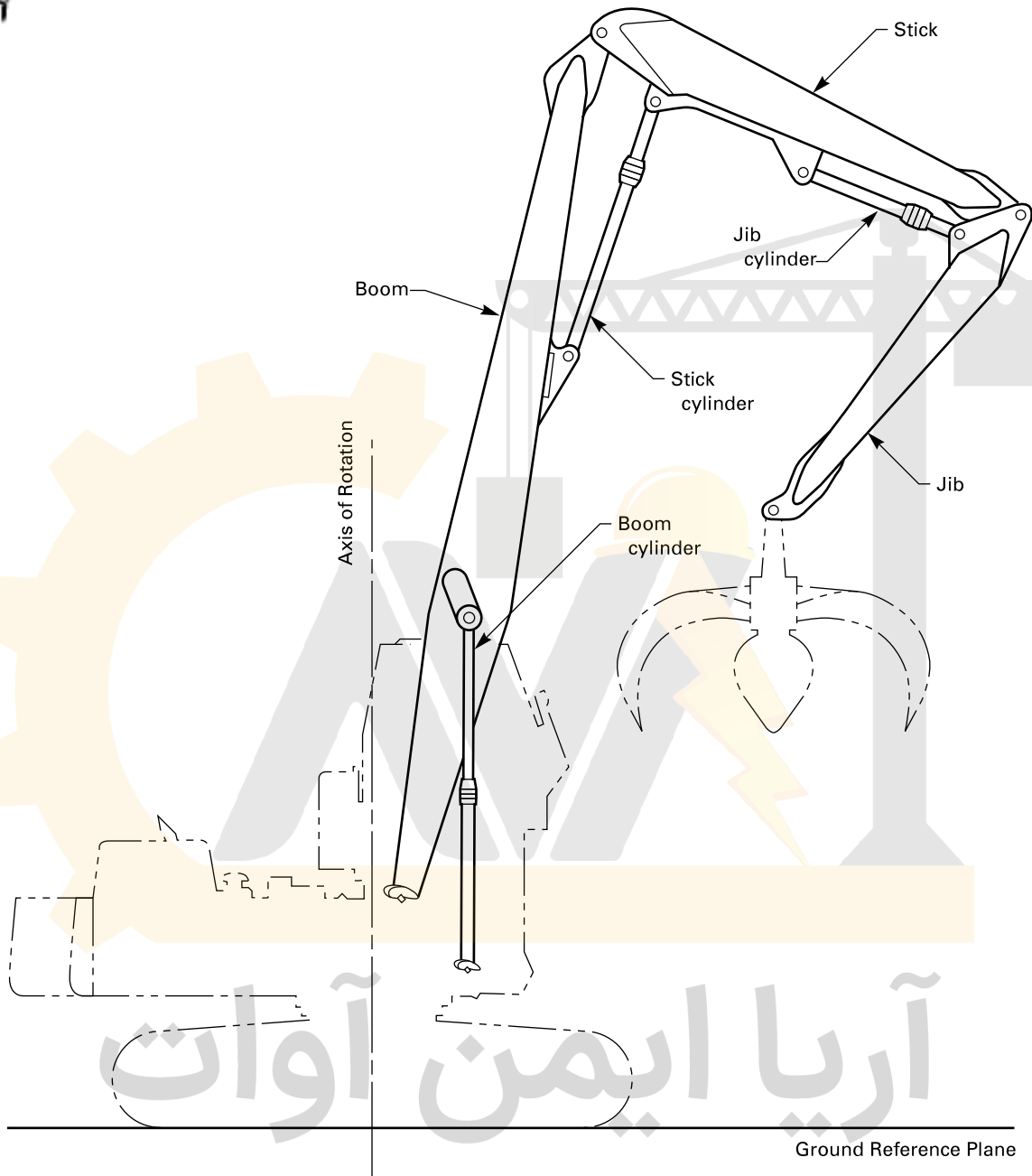

Figure 25-0.2.2-2 Three-Piece Front





Chapter 25-1 Construction and Characteristics

SECTION 25-1.1: LIFT CAPACITY

25-1.1.1 Lift Capacity — Calculation and Verification

Lift capacities for handlers shall be calculated and verified as prescribed in SAE J2518 and in accordance with the conditions and limitations given on the lift capacity chart. Lift capacities shall be determined with the handler as equipped and outfitted by the manufacturer or assembler/modifier with all auxiliary and ancillary equipment included as specified on the lift capacity chart.

25-1.1.2 Lift Capacity Chart

A durable rating chart(s) with legible letters and figures shall be provided with each handler and attached in a location accessible to the operator while at the controls. The lift capacity charts shall conform to SAE J2518, but can be in U.S. Customary units (pounds and feet) with a minimum of 5-ft grid increments.

25-1.1.3 Rated Lift Capacity

The rated lift capacities for handlers shall be defined as in SAE J2518 and shall be determined by taking a percentage of the theoretical lift capacity, limited by hydraulic or stability considerations, whichever is less. The handler lift capacities shall not exceed the following percentages for handlers as defined below.

Type of Handler Mounting or Limiting Condition	Lift Capacity Rating, %
All hydraulic	87
Stability, over side, front, and rear	
Crawler handler	75
Wheel-mounted handler, with or without outriggers	75
Outriggers fully extended and fully supporting the weight of the handler and the load	75
Rail-mounted handler	
without stabilizers extended	85
with stabilizers fully extended	80

SECTION 25-1.2: BACKWARD STABILITY

25-1.2.1 Backward Stability

In those instances where it may be desired to remove the front for transportation or maintenance, backward stability criteria have been established as defined in the following paragraphs. Where backward stabilities are not in compliance with the criteria, the manufacturer or assembler/modifier shall install safety signs in the operator's cab alerting the operator and maintenance personnel of the hazards involved in removing the front or placing the handler in an unstable position. The signs shall include the appropriate signal word(s) according to ANSI Z535.4, and the wording on the sign shall also be included in the operator's manual. The manufacturer or assembler/modifier shall also state whether the unsafe condition occurs when the upper is positioned over the side, front, or rear of the base.

The general conditions for determination of the backward stability margin, applicable to all handlers, are as follows:

- (a) handler to be equipped for operation with the recommended front
- (b) front positioned to impose a minimum forward overturning moment
- (c) handler to be unloaded and without grapple or magnet
- (d) outriggers or stabilizers (if provided) fully retracted and stored in their travel position
- (e) handler to be standing on a firm level supporting surface; rail-mounted handlers to be standing on a level track
- (f) operating weight and conditions as specified in SAE J2518
- (g) handler equipped with the specified counterweight

25-1.2.2 Backward Stability Conditions With Front Installed

The following shall be acceptable backward stability conditions:

- (a) For crawler handlers, the horizontal distance from the center of gravity of the entire handler to the axis of rotation shall not exceed 70% of the horizontal distance from the axis of rotation to the backward tipping axis in the least stable direction.



...el- and rail-mounted handlers, with the lon-
... of the upper-structure perpendicular to the
...al axis of the base, the total load on all wheels on
the side of the base under the front shall not be less than
15% of the total weight of the handler.

(c) For wheel- and rail-mounted handlers, with the lon-
gitudinal axis of the upper-structure in line with the lon-
gitudinal axis of the base, in either direction, the total load
on all wheels under the lesser loaded end of the base shall
not be less than 15% of the total weight of the handler.

25-1.2.3 Backward Stability Conditions With Front Removed

With the conditions as stated in [para. 25-1.2.1](#), but with
the front removed, the following shall be acceptable back-
ward stability conditions:

(a) For crawler handlers, the horizontal distance from
the center of gravity of the entire handler, less the front, to
the axis of rotation shall not exceed 90% of the horizontal
distance from the axis of rotation to the backward tipping
axis in the least stable position.

(b) For wheel- and rail-mounted handlers, with the lon-
gitudinal axis of the upper-structure less the front perpen-
dicular to the longitudinal axis of the carrier, the total load
on all wheels on the side of the base supporting the least
load shall not be less than 5% of the total weight of the
handler.

SECTION 25-1.3: SWING MECHANISM

25-1.3.1 Swing Control

The swing mechanism shall start and stop smoothly
with controlled acceleration and deceleration. Use of
the swing brake or reversing the control lever to
achieve this criteria is acceptable if it results in the
ability to smoothly control the swing motion and is the
normal operating procedure recommended by the
manufacturer.

25-1.3.2 Swing Braking Means and Locking Device

(a) All handlers shall have a means capable of holding
the upper structure from rotating with respect to the
lower structure. This means shall be capable of being
set in the holding position and remaining so without
further action being required by the operator. After
being applied, the device shall not be dependent upon
an exhaustible energy source.

(b) Means shall be provided to prevent the rotation of
the upper structure during transport. This can be accom-
plished by a swing lock or swing brake.

(c) If the handler is not equipped with a swing lock, the
swing brake shall be applied automatically when the
engine stops.

SECTION 25-1.4: HANDLER TRAVEL

25-1.4.1 Travel Mechanism

(a) On rail-mounted handlers, when the travel
mechanism must be temporarily deactivated in the
normal course of the handler's use, provision shall be
made to disengage the travel mechanism from the cab
or outside the handler body.

(b) On crawler-mounted handlers, travel performance
shall be calculated and specified according to SAE J1309.
The travel and steering mechanism shall be designed so
that it is not possible for both tracks to freewheel without
operator control.

(c) All handlers shall be equipped with a travel alarm
meeting the requirements of ISO 9533.

(d) On wheel-mounted handlers, the travel and
steering mechanism shall be designed to permit a
controlled stop in the event of the loss of engine power.

25-1.4.2 Travel Brakes

(a) Rail-mounted handlers shall be equipped with
brakes capable of bringing the handler to a stop while
descending the maximum grade recommended for
travel. In addition, means shall be provided to engage
brakes manually. Such engagement means shall be
capable of holding the handler stationary on the
maximum grade recommended for travel, and shall
remain engaged in the event of loss of power.

(b) Crawler-mounted handlers shall be equipped with
a service brake system, a secondary brake system, and a
parking brake system that meet the brake performance
requirements specified in ISO 10265. The brake
systems may use common components; however, in
the event of a failure of any single component, the
remaining brake system(s) shall provide handler stopping
capability meeting the secondary brake system perfor-
mance requirements specified. After being applied, the
parking brake system shall not be dependent upon an
exhaustible energy source.

(c) Wheel-mounted handlers shall be equipped with a
service brake system, a secondary brake system, and a
parking brake system and meet the brake performance
requirements defined in ISO 3450. The brake systems
may use common components; however, in the event
of a failure of any single component other than a tire,
the remaining brake system shall provide handler stop-
ping capability meeting the secondary brake system
performance requirements specified. After being
applied, the parking brake system shall not be dependent
upon an exhaustible energy source.

(d) Prior to being placed in service, all new or modified
handlers shall be tested by the manufacturer or assem-
bler/modifier to verify that the brake systems meet
the specifications in (a), (b), and (c).



25-1.5: CONTROLS

25-1.5.1 General

This Section describes two lever-type operating controls for wheel-mounted, crawler-mounted, or rail-mounted handlers on independent tracks.

(a) Primary controls are those that affect the handler's basic functions and are used by the handler operator while at the operator station.

(b) Primary controls for all front and travel functions (except steering, travel direction, and clutch control) shall return to their neutral position automatically when released by the operator. A means shall be provided to disable primary controls for all front and travel functions (except steering, travel direction, and clutch) when the operator leaves the operator's station. This shall be accomplished without an immediate loss of the load.

(c) The function of all controls (except as noted) shall be clearly identified by symbols on affixed labels or diagrams conforming to ISO 6405-1 and ISO 6405-2. Words may be used to complement such symbols or when appropriate symbols have not been standardized. All symbols shall be explained in the operator's manual along with control movement and sequence. The horn control shall be identified by a label or diagram.

(1) The function of controls obviously self-defined by standard practice such as steering wheel, turn signal, etc., or by mounting location such as heater switch or door handle when located on the unit are not required to be labeled.

(2) Where possible, the movement of all controls from their neutral position shall be in the same general direction as the movement of the functions that they control. In their neutral position, there shall be no movement of the functions.

25-1.5.2 Travel Controls

(a) Primary travel controls affect the following basic travel functions: speed, steering, travel direction, service brake (if provided), and clutch (if provided). Secondary controls affect other travel functions (if provided) such as transmission selector, emergency brake, parking brake, turn signal, etc.

(b) The location and direction of movement of the primary travel controls for wheel-mounted and crawler-mounted handlers are illustrated and described in Figures 25-1.5.2-1 and 25-1.5.2-2, respectively. The direction of movement of functions that are controlled (forward, reverse, etc.) are relative to the handler in its normal mode as specified by the manufacturer.

(18) 25-1.5.3 Front Controls

(a) Primary front controls actuate the following on all handlers: boom, stick, swing, and jib or grapple, if so equipped.

(b) Secondary front controls actuate other front functions, such as a grapple, magnet, or combination grapple magnet.

(c) The location and direction of movement of the primary front controls and their functions are illustrated in Figures 25-1.5.3-1 and 25-1.5.3-2. The direction of movement of the functions that are controlled (right, left, etc.) is relative to the operator when sitting in the operator position.

(d) The control arrangement shown in Figures 25-1.5.3-1 and 25-1.5.3-2 are for the primary controls only, and shall be located within the zones as set forth in ISO 6682.

(e) The function of all front controls shall be clearly identified on permanently affixed labels.

(f) The arrangement of secondary controls is not shown; however, they shall be so located as not to interfere with the operation of the primary controls.

(g) When more than one control location is offered for a function or function(s), one location should conform to the recommended practice. Other control locations and arrangements shall be at the discretion of the manufacturer or assembler/modifier.

(h) Control actuating forces shall comply with the values set forth in ISO 10968.

(i) The distance between control levers, adjacent foot pedals, handles, knobs, and other handler parts shall be sufficient to allow operation without unintentional actuation of adjacent controls. See ISO 10968 for suggested minimum clearances. The overlapping of controls is permissible to provide independent and simultaneous control application.

25-1.5.4 Auxiliary Controls

Auxiliary controls actuate all other functions that pertain to overall handler performance such as outriggers/stabilizers, engine speed, engine start and stop, swing brakes, horn, and steering selector. The arrangement of auxiliary controls is not shown; however, they shall be so located such that they do not interfere with the operation of the primary controls.

SECTION 25-1.6: CABS

25-1.6.1 Construction

(a) All cabs and enclosures shall be constructed to protect the upper-structure machinery and operator's station from the weather.

(b) All cab glazing shall be safety glazing material as defined in ANSI Z26.1. Windows shall be in all sides of the cab or operator's compartment. Visibility forward shall include a vertical range adequate to view the attachment when it is in its normal operating position. The front window may have a section that can be readily removed or held open. If the section is of the type held in the open

Figure 25-1.5.2-1 Wheel-Mounted Handler — Primary Travel Control Diagram

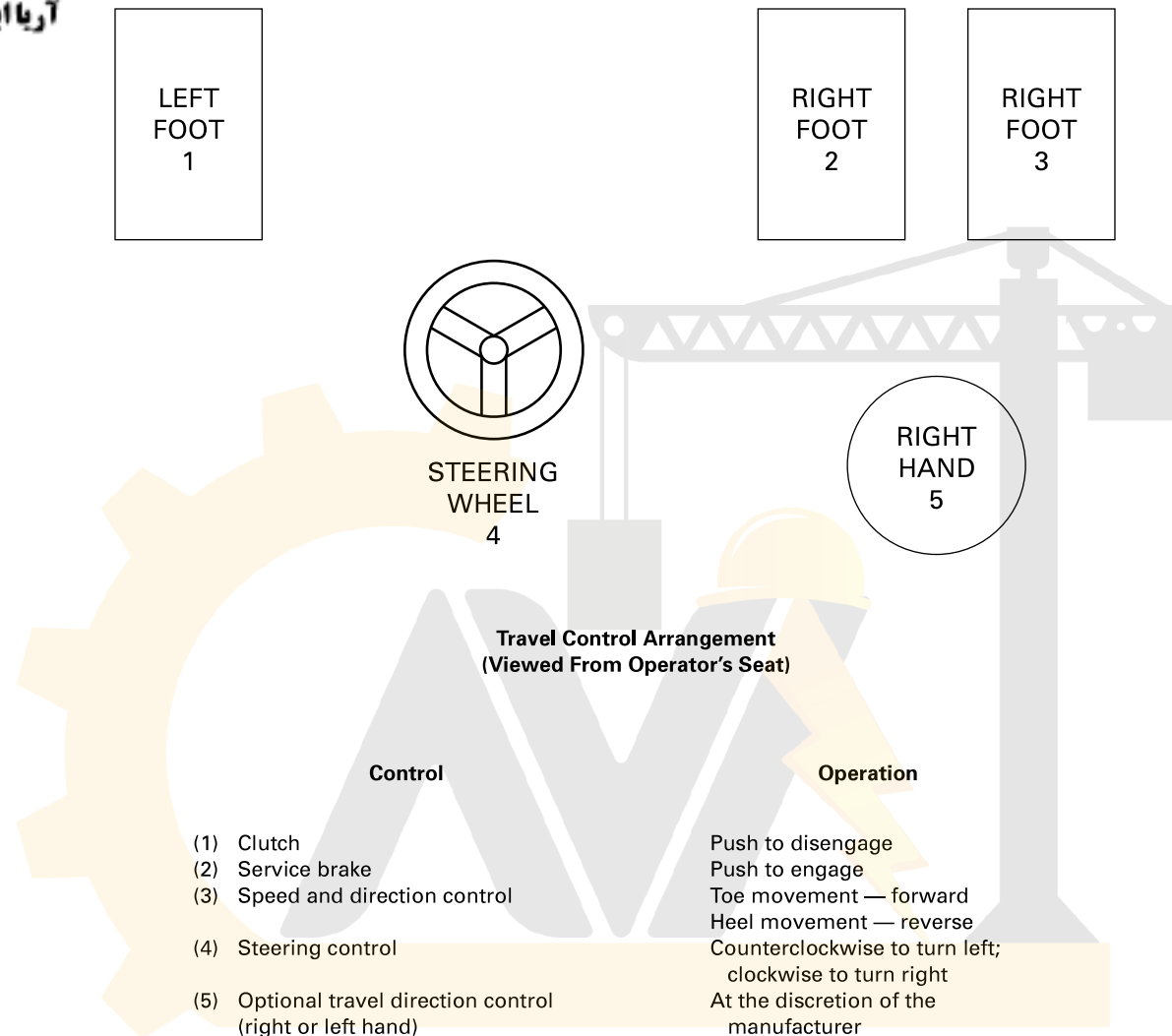

position, it shall be secured to prevent inadvertent closure. The front window shall meet the requirements of ANSI Z26.1, Class 1.

(c) Protective guards shall be fitted when there is danger of flying or falling objects.

(1) For falling objects, a falling object guard structure with a top guard and front window guard meeting the requirements of ISO 10262.

(2) For flying objects, the front window may be laminated glass but all other windows shall be safety glazing plastics as defined in ANSI Z26.1.

(3) Restriction of visibility to the operator during normal operation shall be minimized.

(d) A windshield wiper should be provided on the front window. If the front window material is safety glazing plastic and the handler is equipped with windshield wipers, a suitable surface treatment and a windshield washer shall be provided to resist scratching.

(e) All cab doors shall be restrained from inadvertent opening or closing while traveling or operating the handler. The door adjacent to the operator, if of the swinging type, should open outward and, if of the sliding type, should slide rearward to open.

(f) Two means of egress shall be provided: a door and a second exit. The second exit shall be located on any surface except the surface housing the door or the surface next to the boom section of the front.

(g) A seat belt shall be provided that meets the requirements of ISO 6683 and shall be marked per the requirements of SAE J386.

(h) Any cab opening into the machinery section shall be covered with a fire-resistant door or panel in accordance with ISO 3795.

(i) When a tipping cab is provided, safety signs shall be provided. These signs shall

(1) describe the pinch points when tipping the cab

Figure 25-1.5.2-2 Track-Mounted Handler — Primary Travel Control Diagram



Two-Pedal Travel Control Arrangement

GENERAL NOTE Optional hand-operated levers can be used in place of foot-operated levers.

(18)

Figure 25-1.5.3-1 Primary Front Controls — Three-Piece Fronts

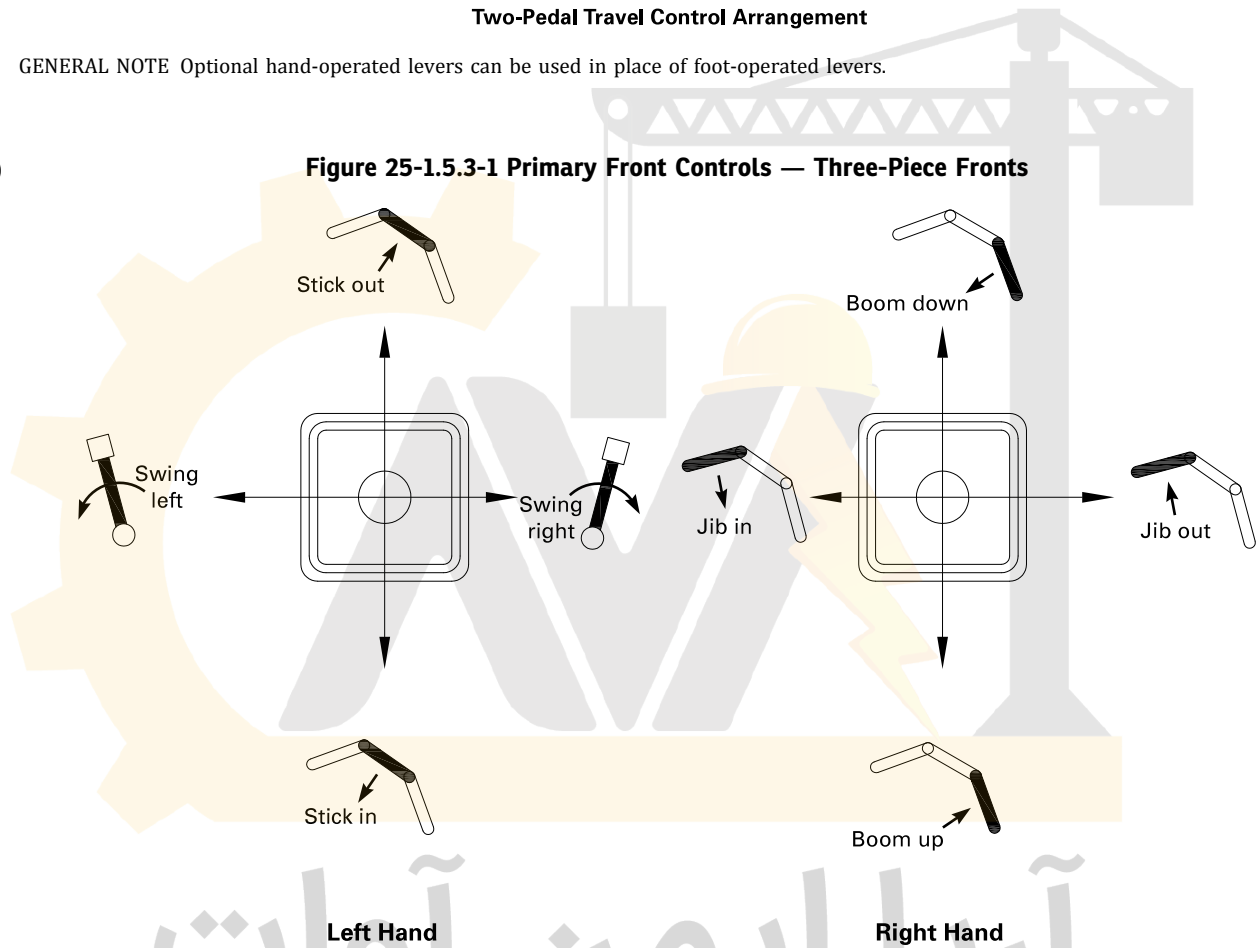

(2) notify that the cab must be secured in place before starting normal production operations of the equipment

(j) Rearview mirrors shall be installed to provide visibility along both sides of the handler. The mirrors shall be constructed of safety glazing material as defined in ANSI Z26.1.

25-1.6.2 Construction of Elevating Cabs

In addition to the requirements of para. 25-1.6.1, the following requirements shall apply:

(a) The lift and descent speed of the operator's cab shall not exceed 1.3 ft/sec (0.4 m/s).

(b) If service or maintenance work is required to be performed with a cab in the raised position, a mechanical support device shall be provided. This device shall be capable of supporting at least twice the mass of the operator's cab. Installation instructions for this device shall be included within the operator's manual.

(c) The elevating control(s) shall be clearly marked and protected against inadvertent actuation.

(d) An auxiliary means located outside the cab shall be provided for the operator to lower the cab to the lowest position or to exit the cab safely, e.g., steps or stairs, in the event normal access is precluded by machine malfunction. A second auxiliary means, located outside the cab, shall be provided to lower the cab in the event a malfunction occurs and/or the operator becomes incapacitated. Both auxiliary means shall meet the requirements of (a).

Figure 25-1.5.3-2 Primary Front Controls — Two-Piece Fronts

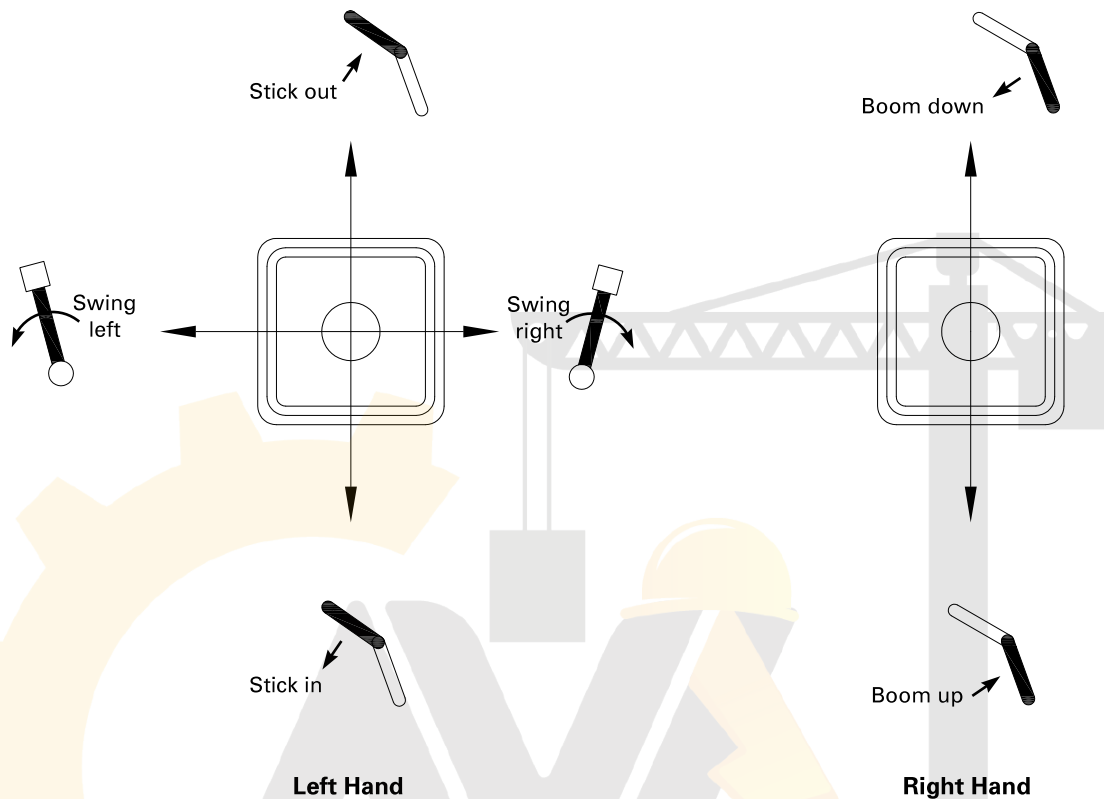

(e) Any hazardous area between the handler main frame and the bottom of the elevated cab shall be identified with a visible safety sign(s) to define any pinch points when lowering the cab.

(f) A seat belt or other protective device shall be provided to prevent the operator from falling from the cab when the handler is used with the cab raised and the door opened.

(g) The elevating cab mechanism shall be equipped with a device to prevent uncontrolled lowering of the cab in the event of a failure of the mechanism.

25-1.6.3 Platforms

(a) Outside platforms, if furnished, should comply with ISO 2867.

(b) Safety signs shall be provided to notify users that riders are not allowed on platforms during operation.

(18) 25-1.6.4 Access to Cab

(a) Handholds and steps shall be provided to enter and exit the cab and provide access to the machinery maintenance panels/doors and should be in accordance with ISO 2867 and ISO 2860.

(b) On rail-mounted equipment, construction of access systems shall conform to the requirements of the Safety Appliance Standards and Power Brakes Requirements of the Federal Railroad Administration.

(c) Safety signs that notify users of the following shall be provided:

- (1) Riders are not allowed on steps during operation.
- (2) Face the access system and use three points of contact during ingress and egress.

SECTION 25-1.7: GENERAL REQUIREMENTS

25-1.7.1 Identification

Each handler manufacturer shall attach a durable label that is legibly marked with the following information:

- (a) the assembler's/modifier's name and address
- (b) the assembler's/modifier's model identification for the handler
- (c) the handler manufacturer's name and address
- (d) the handler manufacturer's model identification and serial number
- (e) the front manufacturer's name and address
- (f) the front manufacturer's model identification and serial number
- (g) the weight of the counterweight provided on the handler

25-1.7.2 Exhaust Gases

(a) Engine exhaust gases shall be piped to the outside of the cab and discharged in a direction away from the operator. All exhaust pipes shall be guarded or insulated



at contact with personnel when performing service.

Hydraulic, oil, and fuel lines shall not cross or run next to the exhaust system.

(18) **25-1.7.3 Fronts**

(a) Fronts shall be used only for the purpose recommended by the front manufacturer.

(b) Handlers should be equipped with a device on the lifting end of the boom, stick, and jib cylinders that is intended to prevent the front from uncontrolled lowering in the event of a hydraulic line failure.

(18) **25-1.7.4 Outriggers/Stabilizers**

(a) Means shall be provided to hold all outriggers/stabilizers in the retracted position while traveling, and in the extended position when set for operating.

(b) Power-actuated jacks, where used, shall be provided with the means (such as integral load hold check valves on hydraulic cylinders, and mechanical locks) to prevent loss of support under load.

25-1.7.5 Rail-Mounted Handlers

(a) *Truck Wedges or Jacks.* Rail-mounted handlers shall be provided with removable wedges or jacks for transmitting loads from the base directly to the wheels without permitting the truck springs to function when handling loads. These wedges shall be removable, or the jacks releasable, in a manner positive for transit.

(b) *Truck Center Pins.* Each truck center pin shall be provided with a connecting means, such as a king bolt, to permit the truck weight to contribute to handler stability.

25-1.7.6 Welded Construction

All repair welding procedures shall be performed by qualified persons. Welding on load-sustaining members shall be performed in accordance with ANSI/AWS D14.3. Where special steels or other materials are used, the manufacturer shall provide welding procedures.

Repair welding on structural components shall not be done before obtaining the manufacturer's or qualified person's recommendations.

25-1.7.7 Guards for Moving Parts

(a) Exposed moving parts such as gears, set screws, projecting keys, chains, chain sprockets, and reciprocating or rotating parts that might constitute a hazard under normal operating conditions shall be guarded.

(b) Guards shall be fastened and shall be capable of supporting, without permanent distortion, the weight of a 200-lb (90-kg) person unless the guard is located where it is impossible for a person to step on it.

25-1.7.8 Hydraulic and Pneumatic Line Protection

Exposed lines subject to damage should be protected.

25-1.7.9 Lubricating Points

Lubricating points should be accessible without the necessity of removing guards or other parts.

25-1.7.10 Handler Modifications

Structural modifications or additions and/or hydraulic modifications that affect the capacity or safe operation of the handler shall not be made without the written approval of the manufacturer, assembler/modifier, or a qualified person. Modifications to the handler affecting lifting capacity require a revised lift capacity chart.

25-1.7.11 Miscellaneous

(a) The fuel tank filler pipe shall be located or protected so as not to allow spill or overflow to run onto the engine, exhaust, or electrical equipment of the handler being fueled.

(b) The toolbox, if provided, shall be nonflammable and secured to the handler.

(c) A horn shall be provided that can be operated while allowing the operator to maintain control of the primary function.

(d) A flashing light should be installed on equipment where the operator does not have a 360-deg unobstructed view. A single light may be mounted so that it has 360-deg visibility, or three lights may be used; one on each rear corner and one on the front corner opposite the operator. The light(s) shall activate whenever the swing and/or travel function is engaged.

(e) Means shall be provided for checking the manufacturer's specified pressure settings.

(f) A warning sign shall be installed, visible from the operator's station, warning that electrocution or serious bodily injury may occur unless a minimum clearance of 10 ft (3 m) is maintained between the handler or load for energized power lines up to 50 kV, and that greater clearances are required for higher voltages (refer to [para. 25-3.4.10](#)).

SECTION 25-1.8: ELECTRICAL EQUIPMENT

(a) Magnet or electric motor power wiring and equipment shall comply with ANSI/NFPA 70.

(b) All handlers shall be equipped with a main power disconnect switch of the enclosed type and that is lockable in the open (off) position.

25-1.8.1 Lifting Magnets

(a) A handler used with a lifting magnet shall comply with ASME B30.20, Chapter 20-4, Group IV (Remotely Operated Lifting Magnets). Persons shall not be in



...y to an energized remotely operated lifting
...pt for electrical testing. If a lifting magnet is
...ose proximity to people, it shall comply with
ASME B30.20, Chapter 20-3, Group III (Close Proximity
Operated Lifting Magnets).

(b) A handler used with a lifting magnet that is powered
by an onboard DC generator shall be equipped with a sepa-
rate circuit switch that disconnects the power to the
magnet, or disconnects excitation power to the DC
generator and removes all power to the magnet. The
switch shall be of the enclosed type with provisions
for locking, flagging, or tagging in the open (off) position.
Means for discharging the inductive energy of the magnet
shall be provided.

(c) Indicator or signal lights shall be provided to indi-
cate whether the power to a lifting magnet is on or off. This
light shall be visible to the operator.

SECTION 25-1.9: INSTRUCTION MANUALS

(a) The handler manufacturer or the assembler/modi-
fier shall provide an instruction manual with every
handler. A space in the cab for the safekeeping of the
manual shall be provided. In addition to operating and
preventative maintenance instructions, the manual
shall provide a statement of those factors that alter the
handler's lifting capacity and to the degree to which it
is affected.

(b) In addition to the data required on the lift capacity
chart, the following information shall be provided in the
operator's manual or in supplementary documents
included with the handler:

(1) the manufacturer's or assembler's/modifier's
name, model number, or designation

(2) the serial number of the scrap handling attach-
ment, scrap grapple, and/or magnet

(3) the weight and load capacity of the grapple and/
or magnet

(4) cautionary or warning notes relative to limita-
tions on equipment and operating procedures

(5) hydraulic relief valve settings specified by the
assembler/modifier

(6) hand signals

(c) *Translation of Non-English Documentation Into
English*

(1) Translations of written non-English safety infor-
mation and manuals regarding use, inspection, and main-
tenance shall meet professional industry standards, which
include, but are not limited to, the following:

(-a) translating the complete paragraph message,
instead of word by word

(-b) ensuring grammatical accuracy

(-c) preserving the source document content
without omitting or expanding the text

(-d) translating the terminology accurately

(-e) ensuring that the translation reflects the level
of sophistication of the original document

(2) The finished translation shall be verified for
compliance with (c)(1)(-a) through (c)(1)(-e) by a qual-
ified person having an understanding of the technical
content of the subject matter.

(3) Pictograms used to identify controls shall be
described in the manuals. The pictograms should
comply with ISO 7000, ISO 7296, or other recognized
source, if previously defined. The text of the description
shall meet the criteria of (c)(1) and (c)(2).

(d) Any non-English documentation provided in addi-
tion to English shall be translated and reviewed in accor-
dance with the requirements listed above.

آریا ایمن آوات

Chapter 25-2 Inspection, Testing, and Maintenance

SECTION 25-2.1: INSPECTION — GENERAL

The manufacturer or assembler/modifier shall furnish field assembly, operation, and maintenance information.

25-2.1.1 Inspection Classification

(a) *Initial Inspection.* Prior to initial use, all new or altered handlers shall be inspected by a qualified person to verify compliance with the provisions of this Volume.

(b) *Inspection Intervals.* Inspection procedures for handlers in regular service are divided into two general classifications based upon the intervals at which inspections are performed. The intervals depend upon the nature of the critical components of the handler and the degree of their exposure to wear, deterioration, or malfunction. The two general classifications are herein designated as frequent and periodic, with respective intervals between inspections as defined below.

(1) *Frequent Inspection.* Visual examination by a designated person daily to monthly with records not required.

(2) *Periodic Inspection.* Complete inspection by a qualified person making records of apparent external conditions to provide the basis for a continuing evaluation. To be performed at 1-month to 12-month intervals, or as specifically recommended by the manufacturer or assembler/modifier.

(18) 25-2.1.2 Frequent Inspection

Items such as the following shall be inspected by a designated person for any malfunctions or damage at intervals as defined in [para. 25-2.1.1\(b\)\(1\)](#) or as specifically indicated by the manufacturer or assembler/modifier, including observation during operation for any malfunctions or damage that might appear between inspections. Any damage shall be carefully examined and a determination made as to whether they constitute a hazard and, if so, what additional steps need to be taken to address the hazard.

(a) all controls for maladjustment interfering with proper operation — daily

(b) all controls for excessive wear of components and contamination by lubricants or other foreign matter

(c) all safety devices for malfunction — daily

(d) all hydraulic components, connections, lines, and hoses, particularly those hoses that flex in normal operation of the handler's functions, should be visually inspected for evidence of leakage and physical damage — daily

(e) hooks, pins, clevises, shackles, and latches for deformation, chemical damage, cracks, and wear

(f) electrical apparatus including all controls, safety disconnects, DC generators, cables, leads, and connections for malfunctioning, signs of wear, corrosion, excessive deterioration, dirt, and moisture accumulation

(g) hydraulic system, for proper oil level — daily

(h) tires for condition and recommended inflation pressure

(i) lifting magnets in accordance with ASME B30.20

(j) grapples for proper operation, deformation, cracks, and wear

25-2.1.3 Periodic Inspection

(18)

Complete inspections of the handler shall be performed by a qualified person at intervals as generally defined in [para. 25-2.1.1\(b\)\(2\)](#), depending upon the handler's activity, severity of service, and environment, or as specifically indicated below, or by the manufacturer or assembler/modifier. These inspections shall include the requirements of [para. 25-2.1.2](#) and, in addition, items such as the following. Any deficiencies, including the following, shall be examined and a determination made as to whether they constitute a hazard and, if so, what additional steps need to be taken to address the hazard:

(a) deformed, cracked, or corroded members in the handler structure and entire front assembly

(b) loose or missing bolts, nuts, or other fasteners

(c) worn, cracked, or distorted parts such as pins, bearings, wheels, shafts, gears, rollers, locking and clamping devices, bumpers, and stops

(d) excessive wear on brake and clutch system parts

(e) excessively worn or damaged track drive components, wheels, or tires and rims

(f) travel steering, braking, and locking devices, for malfunction

(g) hydraulic and pneumatic hose, fittings, and tubing for

(1) evidence of leakage at the surface of the flexible hose or its junction with the metal couplings



ring or abnormal deformation of the outer surface of the hydraulic or pneumatic hose
leakage at threaded or clamped joints that cannot be eliminated by normal tightening or recommended procedures

(4) evidence of excessive abrasion or scrubbing on the outer surface of a hose, rigid tube, or fitting

(h) hydraulic and pneumatic pumps and motors

(1) loose bolts or fasteners

(2) leaks at joints between sections

(3) shaft seal leaks

(4) unusual noises or vibration

(5) loss of operating speed

(6) excessive heating of the fluid

(7) loss of pressure

(i) hydraulic and pneumatic valves

(1) cracks in valve housing

(2) improper return of spool to neutral position

(3) leaks at spools or joints

(4) sticking spools

(5) failure of relief valves to attain correct pressure setting

(6) relief valve pressures shall be checked as specified by the manufacturer or assembler/modifier

(j) hydraulic and pneumatic cylinders

(1) drifting caused by fluid leaking across the piston seals

(2) rod seals leakage

(3) leaks at welded joints

(4) scored, nicked, or dented cylinder rods

(5) dented case (barrel)

(6) loose or deformed rod eyes or connecting joints

(k) *Hydraulic Filters*. Evidence of rubber particles on the filter element that may indicate hose, "O" ring, or other rubber component deterioration. Metal chips or pieces on the filter may denote failure in pumps, motors, or cylinders. Further checking will be necessary to determine the origin of the problem before corrective action can be taken.

25-2.1.4 Handlers Not in Regular Use

(a) A handler that has been idle for a period of 2 months or more, but less than 6 months, shall be given an inspection by a qualified person conforming with the requirements of [para. 25-2.1.2](#) before being placed in service.

(b) A handler that has been idle for a period of over 6 months shall be given a complete inspection by a qualified person conforming with the requirements of [paras. 25-2.1.2](#) and [25-2.1.3](#) before being placed in service.

(c) Standby handlers shall be inspected by a qualified person at least semiannually in accordance with the requirements of [para. 25-2.1.2](#). Handlers that are exposed to adverse environmental conditions should be inspected more frequently.

25-2.1.5 Inspection Records

(a) Dated records for periodic inspections shall be made on critical items such as brakes, structural members, hydraulic and pneumatic cylinders, and hydraulic and pneumatic relief pressure valves.

(b) Records for magnets shall be in accordance with ASME B30.20, and records for grapples (when used) shall be in accordance with the grapple manufacturer's recommendations.

(c) All records should be kept where they are available to personnel.

SECTION 25-2.2: TESTING

25-2.2.1 Operational Tests

(a) Each new production or altered handler shall be tested and the results recorded by the manufacturer or assembler/modifier to the extent necessary to ensure compliance with the operational requirements of this Section. Testing shall include, but is not limited to, the following:

(1) front functions

(2) swinging

(3) traveling

(4) all other controls

(5) all safety devices

(b) Where the complete production handler is not supplied by one manufacturer, such tests shall be conducted at final assembly by the assembler/modifier.

(c) Operational handler test results shall be made available.

SECTION 25-2.3: MAINTENANCE

25-2.3.1 Preventive Maintenance

(a) A preventive maintenance program shall be established based on recommendations by the handler's manufacturer or assembler/modifier. If a qualified person determines that additional maintenance items are required above those recommended by the manufacturer, these should be included in the program. Dated records should be kept on file.

(b) It is recommended that replacement parts be obtained from the original equipment manufacturer.

25-2.3.2 Maintenance Procedure

(a) Before adjustments and repairs are started on a handler, the following precautions shall be taken as applicable:

(1) Place handler on firm level surface where it will cause the least interference with other equipment or operations in the area.

(2) Lower the front to the ground, if possible, or otherwise secure against movement.



Place all controls in the off position and ensure all locking functions are secured from inadvertent motion.

(4) Shutdown the engine; disconnect and lock the main power disconnect switch in the open (off) position.

(5) Render starting means inoperative.

(6) Relieve hydraulic and pneumatic pressure from all circuits before loosening or removing hydraulic components.

(7) Place the mechanical support device [para. 25-1.6.2(b)] in position when servicing an elevating cab.

(b) "Warning" or "Out of Order" signs shall be placed on the handler controls. For rail-mounted handlers, "blue flag" protection shall be employed. Signs or flags shall be removed only by designated personnel.

(c) After adjustments and repairs have been made, the handlers shall not be returned to service until all guards have been reinstalled, trapped air removed from the hydraulic system, safety devices reactivated, and maintenance equipment removed.

25-2.3.3 Adjustments and Repairs

(a) Any hazardous condition disclosed by the inspection requirements of Section 25-2.1 shall be corrected before operation of the handler is resumed. Adjustments and repairs shall be done only by qualified personnel.

(b) Adjustments shall be made within the manufacturer's specified tolerances to maintain correct functioning of components. The following are examples:

(1) functional operating mechanisms

(2) safety devices

(3) control systems

(4) engine and hydraulic systems

(5) braking systems

(c) Repairs or replacements shall be provided as needed for operation. The following are examples:

(1) critical parts of functional operating mechanisms that are cracked, broken, corroded, bent, or excessively worn.

(2) critical parts of the handler's structure that are cracked, bent, broken, or excessively corroded.

(3) damaged or worn pins, clevises, and shackles. Repairs by welding or reshaping are not recommended.

(d) Replacement parts should be purchased from the original equipment manufacturer.

25-2.3.4 Lubrication

(a) Lubricating systems should be checked for proper delivery of lubricant.

(b) Machinery shall be stationary while lubricants are being applied and protection provided as called for in paras. 25-2.3.2(a)(1) through 25-2.3.2(a)(5), unless equipped for automatic or remote lubrication.

آریا ایمن آوات

Chapter 25-3 Operation

SECTION 25-3.1: QUALIFICATIONS AND RESPONSIBILITIES

25-3.1.1 Qualified Operators

(a) Handlers shall be operated only by the following personnel:

- (1) qualified operators
- (2) trainees under the supervision of a qualified person
- (3) maintenance personnel who have completed all trainee qualifications when such are necessary in the performance of their duties
- (4) authorized inspectors who have completed all training qualifications when such are necessary in the performance of their duties for the type of handler being inspected

(b) No one other than personnel specified in (a) shall enter a handler cab, with the exception of supervisors or individuals authorized by a supervisor whose duties require them to do so, and then only in the performance of their duties.

25-3.1.2 Requirements for Qualified Operators

(a) Operators shall meet the following physical qualifications unless it can be shown that failure to meet the qualifications will not affect the operation of the handler:

- (1) vision of at least 20/30 Snellen in one eye and 20/50 in the other, with or without corrective lenses.
- (2) ability to distinguish colors, regardless of position, if color differentiation is required.
- (3) adequate hearing, to meet operational demands, with or without hearing aid.
- (4) sufficient strength, endurance, agility, coordination, and speed of reaction to meet operational demands.
- (5) sufficient depth perception, field of vision, reaction time, manual dexterity, and coordination to meet operational demands.
- (6) medical evidence that an operator is not subject to seizures or loss of physical control, which could render a hazard to the operator or others.

(7) each operator or operator trainee shall successfully pass with a negative result, a substance abuse test. The level of testing will be determined by the standard practice for the industry where the handler is employed,

and this test shall be confirmed by a recognized laboratory service.

(b) Operator skill requirements shall include

(1) the ability to read and understand the manufacturer's operation and instruction manual (refer to [Section 25-1.9](#))

(2) evidence of successfully meeting the physical qualifications defined in (a)

(3) satisfactory demonstration of knowledge covering handler lift capacity, operational characteristics, travel, controls, use of attachments, and casualty control skills in response to potentially hazardous incidents such as fire, power line contact, loss of stability, or control malfunctions, as well as characteristics and performance issues appropriate to the handler type for which the individual is being qualified

(4) satisfactory completion of an operation test demonstrating proficiency with the specific type handler for which the individual is being qualified, including both pre-start and post-start inspection, maneuvering skills, shutdown, and securing procedures

(c) Satisfactory demonstration of operator requirements defined in (b) shall be determined and recorded by a qualified person.

25-3.1.3 Responsibilities

While the organizational structure of various projects may differ, the following roles are described here for purposes of delineating responsibilities. All responsibilities listed below shall be assigned in the work site organization. (A single individual may perform one or more of these roles.)

(a) *Owner.* The owner has custodial control of a handler by virtue of lease or ownership.

(b) *User.* The user arranges the handler's presence on a work site and controls its use there.

(c) *Operator.* The operator directly controls the handler's functions.

25-3.1.3.1 Responsibilities of the Owner and User

25-3.1.3.1.1 The owner's responsibilities shall include the following:

(a) provide a handler that meets the requirements of [Chapters 25-1](#) and [25-2](#) as well as specific job requirements defined by the user



provide a handler and all necessary components, and by the manufacturer, that meet the user's listed configuration and capacity

(c) provide all applicable load/capacity chart(s) and diagrams

(d) provide additional technical information pertaining to the handler, necessary for operation, when requested by the user

(e) provide field assembly, disassembly, operation, maintenance information, and warning decals and placards installed as prescribed by the manufacturer

(f) establish an inspection, testing, and maintenance program in accordance with [Chapter 25-2](#), and inform the user of the requirements of this program

(g) designate personnel for the purpose of maintenance, repair, transport, assembly, and disassembly

25-3.1.3.1.2 The user's responsibilities shall include the following:

(a) comply with the requirements of this Volume, manufacturer's requirements, and those regulations applicable at the work site

(b) use supervisors for handler activities that meet the requirements for a qualified person as defined in [para. 25-0.2.2](#)

(c) ensure that the handler is in proper operating condition prior to initial use at the work site

(1) verify that the owner has provided documentation that the handler meets the requirements of [para. 25-2.1.5](#)

(2) verify that a frequent inspection has been performed as defined in [para. 25-2.1.2](#)

(d) verify that the handler has the necessary lifting capacity to perform the proposed lifting operations in the planned configuration

(e) use operators that meet the requirement of [paras. 25-3.1.1](#) and [25-3.1.2](#) and are qualified to perform the tasks that will be required with the handler to which they are assigned to operate

(f) ensure the assigned operator(s) has been notified of adjustments or repairs that have not yet been completed, prior to commencing operations

(g) designate personnel for the purposes of maintenance, repair, transport, assembly, and disassembly

(h) ensure that all personnel involved in maintenance, repair, transport, assembly, disassembly, and inspection are aware of their responsibilities, assigned duties, and the associated hazards

(i) ensure that the inspection, testing, and maintenance programs specified by the handler owner are followed

25-3.1.3.2 Responsibilities of the Operator. The operator shall be responsible for the following listed items. The operator shall not be responsible for hazards or conditions that are not under their direct control. Whenever the operator has doubts about the safety of the operation, the operator shall stop the

handler functions in a controlled manner. Operations shall resume only after safety concerns have been addressed.

The operator's responsibilities shall include the following:

(a) review the requirements for the handler.

(b) understand and apply the information contained in the manufacturer's operating manual.

(c) understand the handler functions and limitations as well as its particular operating characteristics.

(d) use the handler load/capacity chart(s) and diagrams and comply with all notes and warnings related to the lift charts to confirm the correct handler configuration.

(e) refuse to operate the handler when any portion of the load or handler would enter the prohibited zone of energized power lines as defined in [para. 25-3.4.10](#).

(f) perform a daily inspection as specified in [paras. 25-2.1.3\(a\)](#), [25-2.1.3\(c\)](#), [25-2.1.3\(d\)](#), and [25-2.1.3\(g\)](#).

(g) promptly report the need for any adjustment or repairs to a designated person.

(h) follow applicable lock out/tag out procedures.

(i) not operate the handler when physically or mentally unfit.

(j) ensure that all controls are in the off or neutral position and that all personnel are in the clear before energizing the handler or starting the engine.

(k) wear the seat belt provided when operating the handler.

(l) not engage in any practice that will divert his/her attention while actually operating the handler controls.

(m) test the handler function controls that will be used, and operate the handler only if those function controls respond properly.

(n) operate handler functions, under normal operating conditions, in a smooth and controlled manner.

(o) know and follow the procedures specified by the manufacturer or approved by a qualified person for assembly, disassembly, and set up of the handler.

(p) know how to travel the handler.

(q) observe each outrigger during extension, setting, and retraction or use a signalperson to observe each outrigger during extension, setting, or retraction.

(r) know the standard and special signals as specified in [Section 25-3.3](#) and respond to such signals from the designated signalperson. (When a signalperson is not required, the operator is then responsible for the movement of the handler. However, the operator shall obey a stop signal at all times, no matter who gives it.)

SECTION 25-3.2: HANDLING THE LOAD

25-3.2.1 Size of Load

(a) No operator shall attempt to lift a load in excess of the handler's specified lift capacity.



oads, which are not accurately known, are to person responsible for the lift shall determine weight of the load does not exceed the handler's rating at the radius and height at which the load is to be lifted.

25-3.2.2 Holding the Load

- (a) The operator shall not leave the controls while a load is suspended.
- (b) No person shall be permitted to stand or pass under a suspended load.

(18) 25-3.2.3 Moving the Load

- (a) The operator shall verify that
 - (1) the handler is on firm footing
 - (2) the lift and swing path is clear of obstructions
 - (3) all persons are clear of the swing radius of the handler and the outrigger/stabilizer
- (b) During lifting operations, care should be taken that the load, front, or other parts of the handler do not contact any obstruction.
- (c) The operator shall allow for movement of the attachment or the load in all directions, maintaining clearance with the cab.
- (d) The operator should avoid carrying loads over people.
- (e) When two or more handlers are used to lift one load, one designated person shall be responsible for the operation. That person shall analyze the operation and instruct all personnel involved in the proper positioning, and the movements to be made.
- (f) Before traveling a handler with a load, it shall be determined that this practice is not prohibited by the manufacturer. The operator or designated person shall determine the safest load position, front location, ground support, travel route, and speed of movement. The front should be carried in line with the direction of travel. If necessary, a tag or restraint line should be used to control swinging of the load.
- (g) When rotating the handler, the rotational speed shall be such that the load and/or lifting device does not swing out beyond a radius at which it can be controlled.
- (h) Care should be taken to avoid side loading of the handler's front.

25-3.2.4 Personnel

- (a) Lifting of personnel with a handler is prohibited.
- (b) Personnel shall not be permitted to ride on lifting devices or any other part of the handler that is not designated for this purpose by the manufacturer.

SECTION 25-3.3: SIGNALS

25-3.3.1 Standard Signals

Signals to the operator shall be in accordance with the standards prescribed in [para. 25-3.3.2](#) unless voice communication equipment (telephone, radio, or equivalent) is utilized. Signals shall be discernible or audible at all times. No response shall be made unless signals are clearly understood.

25-3.3.2 Hand Signals

The hand signals used shall be in accordance with [Figure 25-3.3.2-1](#) and shall be provided or posted conspicuously at the job site, for use of both signalperson and operator.

25-3.3.3 Special Signals

For operations not covered by [para. 25-3.3.2](#), or for special conditions that occur from time to time, additions to, or modifications of, the standard signals may be required. In such cases, these special signals shall be agreed upon in advance by both the operator and the signalperson, and should not be in conflict with any standard signals.

25-3.3.4 Instructions

If it is desired to give instructions to the operator, other than those provided by the established signal system, all handler motions shall be stopped.

SECTION 25-3.4: MISCELLANEOUS

25-3.4.1 Cab Protection

Operator cab protection devices shall be chosen by the user. Refer to [para. 25-1.6.1\(c\)](#).

25-3.4.2 Rail Clamps

Rail clamps, if used, shall have some slack between the point of attachment to the rail and the end fastened to the handler. Rail clamps shall not be used as a means of restraining tipping during handler operation.

25-3.4.3 Ballast or Counterweight

Handlers shall not be operated unless the ballast or counterweight specified by the manufacture or assembler/modifier is in place. Under specific conditions, such as during assembly, unusual front configurations, etc., the manufacturer's or assembler's/modifier's recommendations for the amount of ballast or counterweight shall be adhered to. The maximum ballast or counterweight approved by the manufacturer or assembler/modifier for use on a given handler shall not be exceeded.



Rerailing Rail-Mounted Handlers

If a rail-mounted handler has been derailed, a wrecking log or car replacer (or its equivalent) should be used and the handler should be hauled back onto the track by external power.

25-3.4.5 Swinging Rail-Mounted Locomotive Handlers

A rail-mounted handler shall not be swung into a position until it has been ascertained that cars are not being moved on the adjacent track and that proper flag protection has been established.

(18) 25-3.4.6 Footing

Firm footing under both crawler tracks, all tires, or individual outrigger pads shall be provided.

25-3.4.7 Storage

(a) Necessary clothing and personal belongings shall be stored in such a manner as to not interfere with access or operation.

(b) Tools, oil cans, waste, and other necessary articles shall be stored in the toolbox (if provided), and shall not be permitted to lie loose in or about the cab.

25-3.4.8 Refueling

(18)

(a) If a portable container is used to refuel the handler, it shall be a safety-type can equipped with an automatic closing cap and a flame arrester.

(b) Handlers shall not be refueled while the engine is running.

(c) Smoking or open flames shall be prohibited in the refueling area.

25-3.4.9 Fire Extinguishers

(a) A portable fire extinguisher, with a basic minimum extinguisher rating of 10 BC, shall be installed in the handler, preferably in the cab.

(b) Operating and maintenance personnel shall be familiar with the use and care of the fire extinguisher provided.

25-3.4.10 Working Near Power Lines

Handlers shall be operated so that no part of the handler or load enters the danger zone (see [Table 25-3.4.10-1](#) and illustration).

آریا ایمن آوات

Figure 25-3.3.2-1 Material Handler Hand Signals

<p>RAISE LOAD VERTICALLY With either forearm vertical, forefinger pointing up, move hand in small horizontal circle.</p>	<p>LOWER LOAD VERTICALLY With either arm extended downward, forefinger pointing down, move hand in small horizontal circle.</p>
<p>MOVE LOAD IN HORIZONTALLY With either arm extended, hand raised and open toward direction of movement, move hand in direction of required movement.</p>	<p>MOVE LOAD OUT HORIZONTALLY With either arm extended, hand raised and open toward direction of movement, move hand in direction of required movement.</p>
<p>RAISE BOOM With either arm extended horizontally, fingers closed, point thumb upward.</p>	<p>LOWER BOOM With either arm extended horizontally, fingers closed, point thumb downward.</p>

Figure 25-3.3.2-1 Material Handler Hand Signals (Cont'd)

 <p style="text-align: center;">SWING</p> <p style="text-align: center;">With either arm extended horizontally, point with forefinger to direction of swing rotation.</p>	 <p style="text-align: center;">SWING</p> <p style="text-align: center;">With either arm extended horizontally, point with forefinger to direction of swing rotation.</p>
 <p style="text-align: center;">STICK INWARD</p> <p style="text-align: center;">With both hands clenched, point thumbs inward.</p>	 <p style="text-align: center;">STICK OUTWARD</p> <p style="text-align: center;">With both hands clenched, point thumbs outward.</p>
 <p style="text-align: center;">JIB INWARD</p> <p style="text-align: center;">With either arm outstretched horizontally in front of body, close fingers and point thumb in direction of required movement.</p>	 <p style="text-align: center;">JIB OUTWARD</p> <p style="text-align: center;">With either arm outstretched horizontally in front of body, close fingers and point thumb in direction of required movement.</p>
 <p style="text-align: center;">TURN</p> <p style="text-align: center;">Raise forearm with closed fist indicating inside of turn. Move other fist in vertical circle indicating direction of track or wheel rotation.</p>	 <p style="text-align: center;">TURN</p> <p style="text-align: center;">Raise forearm with closed fist indicating inside of turn. Move other fist in vertical circle indicating direction of track or wheel rotation.</p>

Figure 25-3.3.2-1 Material Handler Hand Signals (Cont'd)

<p>COUNTER ROTATE Place hand on head indicating side of reverse track or wheel rotation. Move other hand in vertical circle indicating forward rotation of other track or wheel.</p>	<p>COUNTER ROTATE Place hand on head indicating side of reverse track or wheel rotation. Move other hand in vertical circle indicating forward rotation of other track or wheel.</p>	
<p>TRAVEL Move fists in vertical circle about each other in direction of track or wheel rotation.</p>		
<p>THIS FAR TO GO With hands raised and open inward, move hands laterally, indicating distance to go.</p>	<p>MOVE SLOWLY Place one hand motionless in front of hand giving motion signal. (Raise load slowly is shown.)</p>	<p>STOP With either arm extended laterally, hand open downward, move arm back and forth.</p>
<p>EMERGENCY STOP With both arms extended laterally, hands open downward, move arms back and forth.</p>		<p>STOP ENGINE Draw thumb or forefinger across throat.</p>

25-3.4.10-1 Required Clearance for Normal Operation Near High Voltage Power Lines

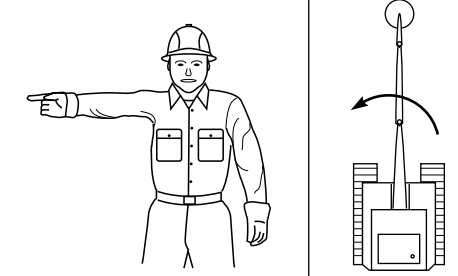
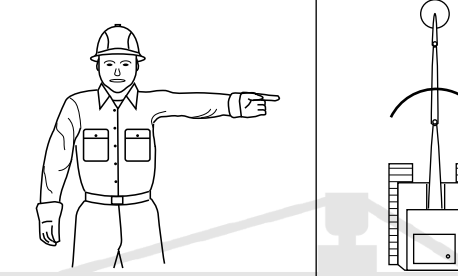
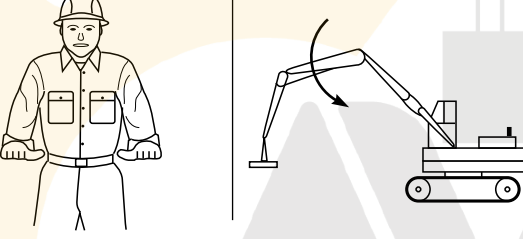
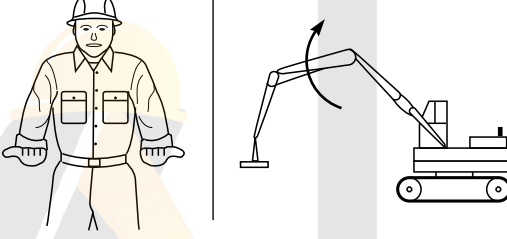
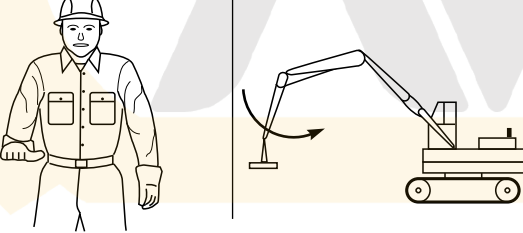
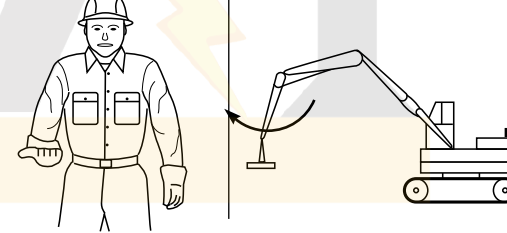
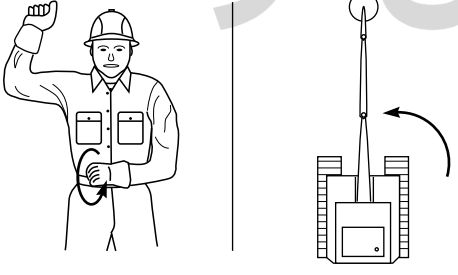
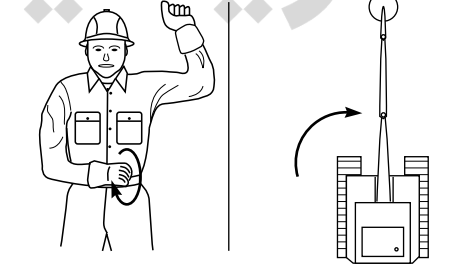
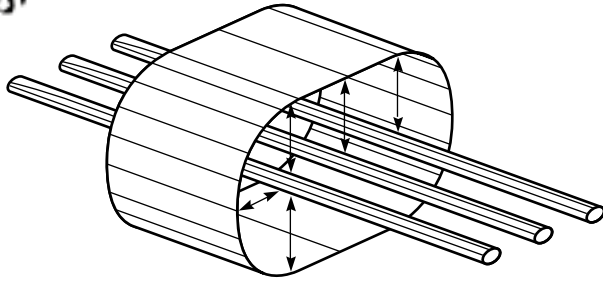

Danger Zone for Handlers Operating Near Electrical Transmission Lines

Normal Voltage, kV (Phase to Phase)	Minimum Required Clearance [Note (1)]	
	ft	m
Up to 50	10	3.05
Over 50 to 200	15	4.6
Over 200 to 350	20	6.1
Over 350 to 500	25	7.62
Over 500 to 750	35	10.67
Over 750 to 1000	45	13.72

NOTE: (1) Environmental conditions such as fog, smoke, or precipitation may require increased clearances.



ASME Services

ASME is committed to developing and delivering technical information. At ASME's Customer Care, we make every effort to answer your questions and expedite your orders. Our representatives are ready to assist you in the following areas:

ASME Press

Codes & Standards

Credit Card Orders

IMechE Publications

Meetings & Conferences

Member Dues Status

Member Services & Benefits

Other ASME Programs

Payment Inquiries

Professional Development

Short Courses

Publications

Public Information

Self-Study Courses

Shipping Information

Subscriptions/Journals/Magazines

Symposia Volumes

Technical Papers

How can you reach us? It's easier than ever!

There are four options for making inquiries* or placing orders. Simply mail, phone, fax, or E-mail us and a Customer Care representative will handle your request.

Mail

ASME

150 Clove Road, 6th Floor

Little Falls, New Jersey

07424-2139

Call Toll Free

US & Canada: 800-THE-ASME

(800-843-2763)

Mexico: 95-800-THE-ASME

(95-800-843-2763)

Fax—24 hours

973-882-1717

973-882-5155

E-Mail—24 hours

customer@asme.org

آریا ایمن آوات

*Customer Care staff are not permitted to answer inquiries about the technical content of this code or standard. Information as to whether or not technical inquiries are issued to this code or standard is shown on the copyright page. All technical inquiries must be submitted in writing to the staff secretary. Additional procedures for inquiries may be listed within.



30.25-2018

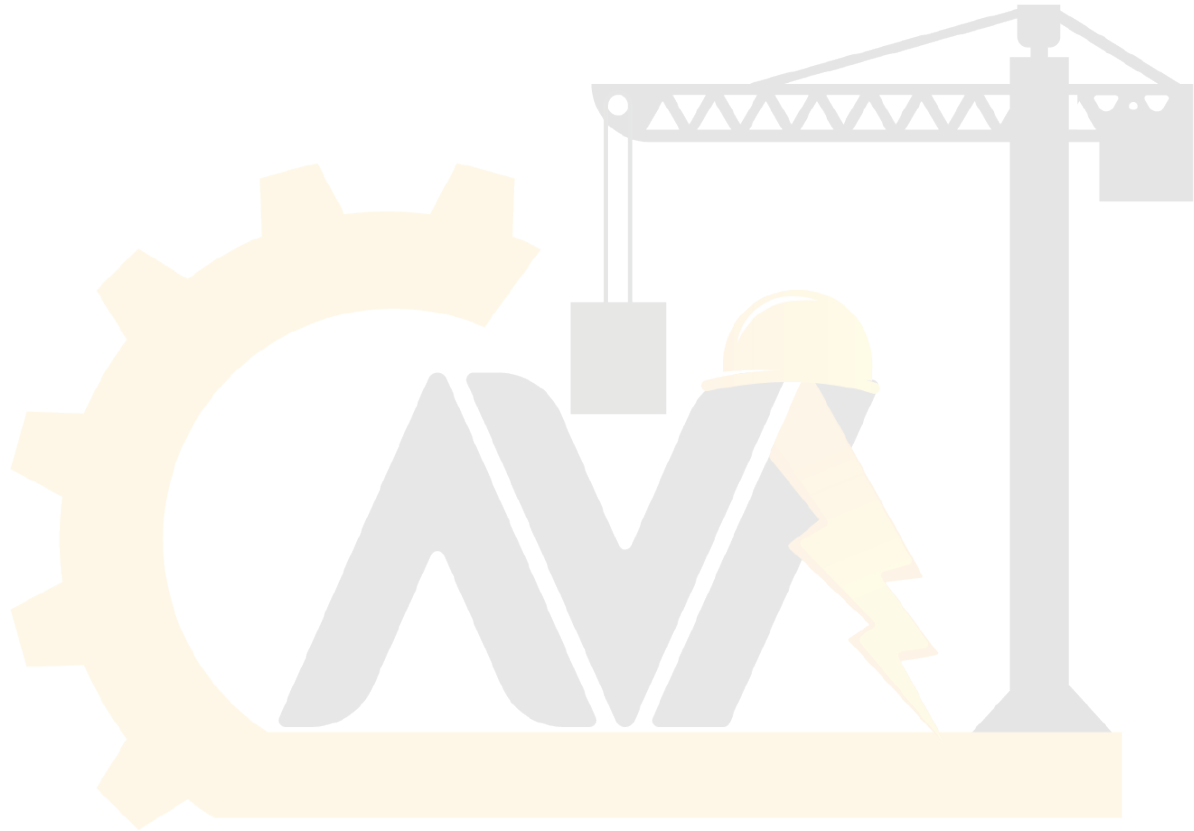

آریا ایمن آوات

ISBN 978-0-7918-7222-2



9 780791 872222



J 1 4 6 1 T