



ASME B30.26-2015
(Revision of ASME B30.26-2010)

Rigging Hardware

**Safety Standard for Cableways,
Cranes, Derricks, Hoists, Hooks, Jacks,
and Slings**

AN AMERICAN NATIONAL STANDARD



**The American Society of
Mechanical Engineers**



ASME B30.26-2015
(Revision of ASME B30.26-2010)

Rigging Hardware

**Safety Standard for Cableways,
Cranes, Derricks, Hoists, Hooks, Jacks,
and Slings**

AN AMERICAN NATIONAL STANDARD



**The American Society of
Mechanical Engineers**

Two Park Avenue • New York, NY • 10016 USA



Date of Issuance: October 7, 2015

The next edition of this Standard is scheduled for publication in 2020. This Standard will become effective 1 year after the Date of Issuance.

ASME issues written replies to inquiries concerning interpretations of technical aspects of this Standard. Interpretations are published on the ASME Web site under the Committee Pages at <http://cstools.asme.org/> as they are issued. Interpretations will also be included with each edition.

Errata to codes and standards may be posted on the ASME Web site under the Committee Pages to provide corrections to incorrectly published items, or to correct typographical or grammatical errors in codes and standards. Such errata shall be used on the date posted.

The Committee Pages can be found at <http://cstools.asme.org/>. There is an option available to automatically receive an e-mail notification when errata are posted to a particular code or standard. This option can be found on the appropriate Committee Page after selecting “Errata” in the “Publication Information” section.

ASME is the registered trademark of The American Society of Mechanical Engineers.

This code or standard was developed under procedures accredited as meeting the criteria for American National Standards. The Standards Committee that approved the code or standard was balanced to assure that individuals from competent and concerned interests have had an opportunity to participate. The proposed code or standard was made available for public review and comment that provides an opportunity for additional public input from industry, academia, regulatory agencies, and the public-at-large.

ASME does not “approve,” “rate,” or “endorse” any item, construction, proprietary device, or activity.

ASME does not take any position with respect to the validity of any patent rights asserted in connection with any items mentioned in this document, and does not undertake to insure anyone utilizing a standard against liability for infringement of any applicable letters patent, nor assumes any such liability. Users of a code or standard are expressly advised that determination of the validity of any such patent rights, and the risk of infringement of such rights, is entirely their own responsibility.

Participation by federal agency representative(s) or person(s) affiliated with industry is not to be interpreted as government or industry endorsement of this code or standard.

ASME accepts responsibility for only those interpretations of this document issued in accordance with the established ASME procedures and policies, which precludes the issuance of interpretations by individuals.

No part of this document may be reproduced in any form,
in an electronic retrieval system or otherwise,
without the prior written permission of the publisher.

The American Society of Mechanical Engineers
Two Park Avenue, New York, NY 10016-5990

Copyright © 2015 by
THE AMERICAN SOCIETY OF MECHANICAL ENGINEERS
All rights reserved
Printed in U.S.A.

CONTENTS

Foreword	v
Committee Roster	vii
B30 Standard Introduction	ix
Summary of Changes	xii
Chapter 26-0 Scope, Definitions, Personnel Competence, Translations, and References	1
Section 26-0.1 Scope	1
Section 26-0.2 Definitions	1
Section 26-0.3 Personnel Competence	2
Section 26-0.4 Translations	2
Section 26-0.5 References	2
Chapter 26-1 Shackles — Selection, Use, and Maintenance	3
Section 26-1.0 Scope	3
Section 26-1.1 Types and Materials	3
Section 26-1.2 Design Factor	3
Section 26-1.3 Rated Loads	3
Section 26-1.4 Proof Test	3
Section 26-1.5 Identification	4
Section 26-1.6 Effects of Environment	4
Section 26-1.7 Training	4
Section 26-1.8 Inspection, Repair, and Removal	4
Section 26-1.9 Operating Practices	5
Chapter 26-2 Adjustable Hardware — Selection, Use, and Maintenance	7
Section 26-2.0 Scope	7
Section 26-2.1 Types and Materials	7
Section 26-2.2 Design Factor	7
Section 26-2.3 Rated Loads	7
Section 26-2.4 Proof Test	7
Section 26-2.5 Identification	7
Section 26-2.6 Effects of Environment	7
Section 26-2.7 Training	11
Section 26-2.8 Inspection, Repair, and Removal	11
Section 26-2.9 Operating Practices	11
Chapter 26-3 Compression Hardware — Selection, Use, and Maintenance	14
Section 26-3.0 Scope	14
Section 26-3.1 Types, Materials, and Assembly	14
Section 26-3.2 Design Factor	14
Section 26-3.3 Rated Loads	14
Section 26-3.4 Proof Test	17
Section 26-3.5 Identification	17
Section 26-3.6 Effects of Environment	17
Section 26-3.7 Training	17
Section 26-3.8 Inspection, Repair, and Removal	17
Section 26-3.9 Operating Practices	18
Chapter 26-4 Links, Master Link Subassemblies, Rings, and Swivels	19
Section 26-4.0 Scope	19
Section 26-4.1 Types and Materials	19



Section 26-4.2	Design Factor	19
Section 26-4.3	Rated Loads	19
Section 26-4.4	Proof Test	20
Section 26-4.5	Identification	20
Section 26-4.6	Effects of Environment	20
Section 26-4.7	Training	20
Section 26-4.8	Inspection, Repair, and Removal	21
Section 26-4.9	Operating Practices	21
Chapter 26-5	Rigging Blocks – Selection, Use, and Maintenance	24
Section 26-5.0	Scope	24
Section 26-5.1	Types and Materials	24
Section 26-5.2	Design Factor	24
Section 26-5.3	Rated Loads	24
Section 26-5.4	Proof Test	24
Section 26-5.5	Identification	24
Section 26-5.6	Effects of Environment	24
Section 26-5.7	Training	24
Section 26-5.8	Inspection, Repair, and Removal	28
Section 26-5.9	Operating Practices	28
Chapter 26-6	Detachable Load-Indicating Devices – Selection, Use, and Maintenance	30
Section 26-6.0	Scope	30
Section 26-6.1	Types and Materials	30
Section 26-6.2	Design Factor	30
Section 26-6.3	Rated Loads	30
Section 26-6.4	Proof Test	30
Section 26-6.5	Identification	30
Section 26-6.6	Effects of Environment	30
Section 26-6.7	Training	30
Section 26-6.8	Calibration, Inspection, Repair, and Removal	34
Section 26-6.9	Operating Practices	34
Figures		
26-1.1.1-1	Shackle Types	3
26-1.9.1-1	Angle of Loading (Shackles)	5
26-1.9.4-1	Typical Shackle Components	6
26-1.9.4-2	Side Loading	6
26-2.1.1-1	Turnbuckles	8
26-2.1.1-2	Eyebolts	8
26-2.1.1-3	Eye Nuts	9
26-2.1.1-4	Swivel Hoist Rings	10
26-2.9.1-1	Angle of Loading (Adjustable Hardware)	12
26-3.1.1-1	Wire Rope Clips	15
26-3.1.1-2	Wedge Sockets	16
26-4.1.1-1	Links and Rings	19
26-4.1.1-2	Swivels	20
26-4.9.1-1	Angle of Loading (Links, Master Link Subassemblies, Rings, and Swivels)	22
26-5.1.1-1	Rigging Block Types	25
26-5.1.1-2	Typical Rigging Block Components	26
26-5.3-1	Block Load Factor Multipliers	27
26-6.1.1-1	Crane Scale — Dynamometer	31
26-6.1.1-2	Link Style Load-Indicating Device	32
26-6.1.1-3	Shackle With Load-Indicating Pin	33



FOREWORD

This American National Standard, Safety Standard for Cableways, Cranes, Derricks, Hoists, Hooks, Jacks, and Slings, has been developed under the procedures accredited by the American National Standards Institute (ANSI). This Standard had its beginning in December 1916 when an eight-page Code of Safety Standards for Cranes, prepared by an ASME Committee on the Protection of Industrial Workers, was presented at the annual meeting of the ASME.

Meetings and discussions regarding safety on cranes, derricks, and hoists were held from 1920 to 1925, involving the ASME Safety Code Correlating Committee, the Association of Iron and Steel Electrical Engineers, the American Museum of Safety, the American Engineering Standards Committee (AESC) [later changed to American Standards Association (ASA), then to the United States of America Standards Institute (USASI), and finally to ANSI], Department of Labor – State of New Jersey, Department of Labor and Industry – State of Pennsylvania, and the Locomotive Crane Manufacturers Association. On June 11, 1925, AESC approved the ASME Safety Code Correlating Committee's recommendation and authorized the project with the U.S. Department of the Navy, Bureau of Yards and Docks, and ASME as sponsors.

In March 1926, invitations were issued to 50 organizations to appoint representatives to a Sectional Committee. The call for organization of this Sectional Committee was sent out on October 2, 1926, and the committee was organized on November 4, 1926, with 57 members representing 29 national organizations. Commencing June 1, 1927, and using the eight-page code published by ASME in 1916 as a basis, the Sectional Committee developed the Safety Code for Cranes, Derricks, and Hoists. The early drafts of this safety code included requirements for jacks but, due to inputs and comments on those drafts, the Sectional Committee decided in 1938 to make the requirements for jacks a separate code. In January 1943, ASA B30.2-1943 was published, addressing a multitude of equipment types and in August 1943, ASA B30.1-1943 was published addressing just jacks. Both documents were reaffirmed in 1952 and widely accepted as safety standards.

Due to changes in design, advancement in techniques, and general interest of labor and industry in safety, the Sectional Committee, under the joint sponsorship of ASME and the Bureau of Yards and Docks (now the Naval Facilities Engineering Command), was reorganized on January 31, 1962, with 39 members representing 27 national organizations. The new committee changed the format of ASA B30.2-1943 so that the multitude of equipment types it addressed could be published in separate Volumes that could completely cover the construction, installation, inspection, testing, maintenance, and operation of each type of equipment that was included in the scope of ASA B30.2. This format change resulted in the initial publication of B30.3, B30.5, B30.6, B30.11, and B30.16 being designated as Revisions of B30.2 with the remainder of the B30 Volumes being published as totally new volumes. ASA changed its name to USASI in 1966 and to ANSI in 1969, which resulted in B30 Volumes from 1943 to 1968 being designated as either ASA B30, USAS B30, or ANSI B30 depending on their date of publication.

In 1982, the Committee was reorganized as an Accredited Organization Committee, operating under procedures developed by ASME and accredited by ANSI. This Standard presents a coordinated set of rules that may serve as a guide to government and other regulatory bodies and municipal authorities responsible for the guarding and inspection of the equipment falling within its scope. The suggestions leading to accident prevention are given both as mandatory and advisory provisions; compliance with both types may be required by employers of their employees.

In case of practical difficulties, new developments, or unnecessary hardship, the administrative or regulatory authority may grant variances from the literal requirements or permit the use of other devices or methods, but only when it is clearly evident that an equivalent degree of protection is thereby secured. To secure uniform application and interpretation of this Standard, administrative or regulatory authorities are urged to consult the B30 Committee, in accordance with the format described in the introduction of Section IX, before rendering decisions on disputed points.



Safety codes and standards are intended to enhance public safety. Revisions result from commitment and consideration of factors such as technological advances, new data, and changing environmental and industry needs. Revisions do not imply that previous editions were inadequate.

The first edition of this Volume was B30.26-2004, published on May 20, 2005. The second edition, B30.26-2010, which was published on June 30, 2010, added Chapter 26-6, Detachable Load-Indicating Devices — Selection, Use, and Maintenance. This 2015 Edition incorporates many global B30 changes, including addition of Sections on personnel competence, translations, and references; addition of general information paragraphs in the inspection Sections; and other revisions. This Edition, which was approved by the B30 Committee and by ASME, was approved by ANSI and designated as an American National Standard on August 6, 2015.



آريا ايمن آوات



ASME B30 COMMITTEE

Safety Standard for Cableways, Cranes, Derricks, Hoists, Hooks, Jacks, and Slings

(The following is the roster of the Committee at the time of approval of this Standard.)

STANDARDS COMMITTEE OFFICERS

B. D. Closson, *Chair*
T. L. Blanton, *Vice Chair*
K. M. Hyam, *Secretary*

STANDARDS COMMITTEE PERSONNEL

N. E. Andrew, LTS Cranes Mechanical
M. Eggenberger, *Alternate*, Berry Contracting, Inc.
G. Austin, Terex Corp.
T. L. Blanton, NACB Group, Inc.
R. Ohman, *Alternate*, Verde Concepts, Inc.
P. A. Boeckman, The Crosby Group
C. E. Lucas, *Alternate*, The Crosby Group
P. W. Boyd, The Boeing Co.
M. E. Brunet, The Manitowoc Co.
A. L. Calta, *Alternate*, The Manitowoc Co.
B. D. Closson, Craft Forensic Services
B. A. Pickett, *Alternate*, Systems Engineering and Forensic Services
J. A. Danielson, The Boeing Co.
D. Decker, Becket, LLC
L. D. DeMark, Equipment Training Solutions, LLC
D. F. Jordan, *Alternate*, BP America
D. W. Eckstine, Eckstine & Associates
G. J. Brent, *Alternate*, NCCCO
R. J. Edwards, NBIS Claims and Risk Management, Inc.
A. J. Egging, National Oilwell Varco
R. Stanoch, *Alternate*, National Oilwell Varco
E. D. Fidler, The Manitowoc Co.
G. D. Miller, *Alternate*, The Manitowoc Co.
J. A. Gilbert, Associated Wire Rope Fabricators
J. L. Gordon, Associated Chain and Lifting Products
N. C. Hargreaves, Hargreaves Consulting, LLC
G. B. Hetherston, E. I. DuPont
R. J. Bolen, *Alternate*, E. I. DuPont
K. M. Hyam, The American Society of Mechanical Engineers
M. M. Jaxtheimer, Navy Crane Center
S. R. Gridley, *Alternate*, Navy Crane Center
P. R. Juhren, Morrow Equipment Co., LLC
M. J. Quinn, *Alternate*, Morrow Equipment Co., LLC
R. M. Kohner, Landmark Engineering Services, Ltd.
D. Duerr, *Alternate*, 2DM Associates, Inc.
A. J. Lusi, Jr., Lumark Consulting, LLP
K. J. Shinn, *Alternate*, K. J. Shinn, Inc.

E. K. Marburg, Columbus McKinnon Corp.
J. R. Burkey, *Alternate*, Columbus McKinnon Corp.
L. D. Means, Means Engineering and Consulting
D. A. Henninger, *Alternate*, Bridon American
M. W. Mills, Liberty Mutual Insurance
D. M. Gordon, *Alternate*, Liberty Mutual Insurance
D. L. Morgan, Critical Lift Consultants, LLC
T. C. Mackey, *Alternate*, WRPS Hanford
W. E. Osborn, Ingersoll Rand
S. D. Wood, *Alternate*, Link-Belt Construction Equipment Co.
R. M. Parnell, Industrial Training International
W. C. Dickinson, Jr., *Alternate*, Industrial Training International
J. T. Perkins, Solarex
J. R. Schober, *Alternate*, American Bridge Co.
J. E. Richardson, Navy Crane Center
K. Kennedy, *Alternate*, Navy Crane Center
D. W. Ritchie, David Ritchie Consultant, LLC
L. K. Shapiro, *Alternate*, Howard I. Shapiro & Associates
J. W. Rowland III, Consultant
D. A. Moore, *Alternate*, Unified Engineering
J. C. Ryan, Boh Bros. Construction Co., LLC
A. R. Ruud, *Alternate*, Atkinson Construction
D. W. Smith, STI Group
S. K. Rammelsberg, *Alternate*, Chicago Bridge & Iron Co.
W. J. Smith, Jr., NBIS Claims and Risk Management, Inc.
J. Schoppert, *Alternate*, NBIS Claims and Risk Management, Inc.
R. S. Stemp, Lampson International, LLC
E. P. Vliet, *Alternate*, Turner Industries Group
R. G. Strain, Advanced Crane Technologies, LLC
J. Sturm, Sturm Corp.
P. D. Sweeney, General Dynamics Electric Boat
B. M. Casey, *Alternate*, General Dynamics Electric Boat
J. D. Wiethorn, Haag Engineering Co.
M. Gardiner, *Alternate*, Haag Engineering Co.
R. C. Wild, CJ Drilling, Inc.
J. Dudley, *Alternate*, Archer Western Contractors
D. N. Wolff, National Crane/Manitowoc Crane Group
J. A. Pilgrim, *Alternate*, Manitowoc Crane Group



HONORARY MEMBERS

J. W. Downs, Jr., Downs Crane and Hoist Co.
J. L. Franks, Consultant
C. W. Ireland, National Oilwell Varco
J. M. Klibert, Lift-All Co., Inc.
R. W. Parry, Consultant
P. S. Zorich, Consultant

B30.26 SUBCOMMITTEE PERSONNEL

C. E. Lucas, *Chair*, The Crosby Group, Inc.
R. Ohman, *Alternate*, Verde Concepts, Inc.
N. E. Andrew, AM/NS Calvert
W. B. Bickett, Jr., *Alternate*, The Babcock & Wilcox Companies
T. Cobb, Columbus McKinnon Forge Operations Chattanooga
B. Considine, Skyzrul, Inc.
D. Decker, Becket, LLC
D. W. Eckstine, Eckstine & Associates
W. Emberger, Exelon Energy

J. A. Gilbert, Associated Wire Rope Fabricators
S. R. Gridley, Navy Crane Center
M. W. Mills, Liberty Mutual Insurance
J. M. Randall, CB&I
S. K. Rammelsberg, *Alternate*, CB&I
M. J. Secrist, Ulven Companies
C. Seale, *Alternate*, Skookum
K. Sellers, Gunnebo-Johnson Corp.
B. D. Todd, Campbell Chain
D. W. Smith, *Contributing Member*, STI Group

B30 INTEREST REVIEW GROUP

O. Akinboboye, Ropetech Engineering Services
J. D. Cannon, Consultant
M. Eggenberger, Berry Contracting, Inc.
A. Gomes Rocha, Belgo Bekaert Arames
H. A. Hashem, Saudi Aramco
J. Hui, School of Civil Engineering, People's Republic of China

A. C. Mattoli, Prowinch, LLC
M. W. Osborne, E-Crane International USA
G. L. Owens, Consultant
W. Rumburg, Crane Consultants, Inc.
C.-C. Tsauro, Institute of Occupational Safety and Health, Taiwan

B30 REGULATORY AUTHORITY COUNCIL

C. Shelhamer, *Chair*, New York City Department of Buildings
A. O. Omran, *Alternate*, New York City Department of Buildings
K. M. Hyam, *Secretary*, The American Society of Mechanical Engineers
G. Beer, Iowa OSHA
L. G. Champion, U.S. Department of Labor/OSHA
W. L. Cooper, Arizona Division of Occupational Safety and Health
R. Feidt, Stephenson Equipment, Inc.

C. Harris, City of Chicago – Department of Buildings
J. L. Lankford, State of Nevada/OSHA
A. Lundeen, State of Washington – Department of Labor and Industries
G. E. Pushies, MIOSHA
C. N. Stribling, Jr., Kentucky Labor Cabinet
T. Taylor, State of Minnesota – Department of Labor and Industry
C. Tolson, State of California – OSH Standards Board

آريا ايمن آوات



SAFETY STANDARD FOR CABLEWAYS, CRANES, DERRICKS, HOISTS, HOOKS, JACKS, AND SLINGS

B30 STANDARD INTRODUCTION

(15)

SECTION I: SCOPE

The ASME B30 Standard contains provisions that apply to the construction, installation, operation, inspection, testing, maintenance, and use of cranes and other lifting and material-movement related equipment. For the convenience of the reader, the Standard has been divided into separate volumes. Each volume has been written under the direction of the ASME B30 Standard Committee and has successfully completed a consensus approval process under the general auspices of the American National Standards Institute (ANSI).

As of the date of issuance of this Volume, the B30 Standard comprises the following volumes:

- | | | | |
|--------|---|--------|-----------------------------|
| B30.1 | Jacks, Industrial Rollers, Air Casters, and Hydraulic Gantries | B30.23 | Personnel Lifting Systems |
| B30.2 | Overhead and Gantry Cranes (Top Running Bridge, Single or Multiple Girder, Top Running Trolley Hoist) | B30.24 | Container Cranes |
| B30.3 | Tower Cranes | B30.25 | Scrap and Material Handlers |
| B30.4 | Portal and Pedestal Cranes | B30.26 | Rigging Hardware |
| B30.5 | Mobile and Locomotive Cranes | B30.27 | Material Placement Systems |
| B30.6 | Derricks | B30.28 | Balance Lifting Units |
| B30.7 | Winches | B30.29 | Self-Erecting Tower Cranes |
| B30.8 | Floating Cranes and Floating Derricks | B30.30 | Ropes ¹ |
| B30.9 | Slings | | |
| B30.10 | Hooks | | |
| B30.11 | Monorails and Underhung Cranes | | |
| B30.12 | Handling Loads Suspended From Rotorcraft | | |
| B30.13 | Storage/Retrieval (S/R) Machines and Associated Equipment | | |
| B30.14 | Side Boom Tractors | | |
| B30.15 | Mobile Hydraulic Cranes
(withdrawn 1982 — requirements found in latest revision of B30.5) | | |
| B30.16 | Overhead Hoists (Underhung) | | |
| B30.17 | Overhead and Gantry Cranes (Top Running Bridge, Single Girder, Underhung Hoist) | | |
| B30.18 | Stacker Cranes (Top or Under Running Bridge, Multiple Girder With Top or Under Running Trolley Hoist) | | |
| B30.19 | Cableways | | |
| B30.20 | Below-the-Hook Lifting Devices | | |
| B30.21 | Lever Hoists | | |
| B30.22 | Articulating Boom Cranes | | |

SECTION II: SCOPE EXCLUSIONS

Any exclusion of, or limitations applicable to the equipment, requirements, recommendations, or operations contained in this Standard are established in the affected volume's scope.

SECTION III: PURPOSE

The B30 Standard is intended to

- (a) prevent or minimize injury to workers, and otherwise provide for the protection of life, limb, and property by prescribing safety requirements
- (b) provide direction to manufacturers, owners, employers, users, and others concerned with, or responsible for, its application
- (c) guide governments and other regulatory bodies in the development, promulgation, and enforcement of appropriate safety directives

SECTION IV: USE BY REGULATORY AGENCIES

These volumes may be adopted in whole or in part for governmental or regulatory use. If adopted for governmental use, the references to other national codes and standards in the specific volumes may be changed to refer to the corresponding regulations of the governmental authorities.

SECTION V: EFFECTIVE DATE

(a) *Effective Date.* The effective date of this Volume of the B30 Standard shall be 1 yr after its date of issuance.

¹ This volume is currently in the development process.



, installation, inspection, testing, maintenance, operation of equipment manufactured and constructed after the effective date of this Volume shall conform to the mandatory requirements of this Volume.

(b) *Existing Installations.* Equipment manufactured and facilities constructed prior to the effective date of this Volume of the B30 Standard shall be subject to the inspection, testing, maintenance, and operation requirements of this Standard after the effective date.

It is not the intent of this Volume of the B30 Standard to require retrofitting of existing equipment. However, when an item is being modified, its performance requirements shall be reviewed relative to the requirements within the current volume. The need to meet the current requirements shall be evaluated by a qualified person selected by the owner (user). Recommended changes shall be made by the owner (user) within 1 yr.

SECTION VI: REQUIREMENTS AND RECOMMENDATIONS

Requirements of this Standard are characterized by use of the word *shall*. Recommendations of this Standard are characterized by the word *should*.

SECTION VII: USE OF MEASUREMENT UNITS

This Standard contains SI (metric) units as well as U.S. Customary units. The values stated in U.S. Customary units are to be regarded as the standard. The SI units are a direct (soft) conversion from the U.S. Customary units.

SECTION VIII: REQUESTS FOR REVISION

The B30 Standard Committee will consider requests for revision of any of the volumes within the B30 Standard. Such requests should be directed to

Secretary, B30 Standard Committee
ASME Codes and Standards
Two Park Avenue
New York, NY 10016-5990

Requests should be in the following format:

- Volume: Cite the designation and title of the volume.
Edition: Cite the applicable edition of the volume.
Subject: Cite the applicable paragraph number(s) and the relevant heading(s).
Request: Indicate the suggested revision.
Rationale: State the rationale for the suggested revision.

Upon receipt by the Secretary, the request will be forwarded to the relevant B30 Subcommittee for consideration and action. Correspondence will be provided to

the requester defining the actions undertaken by the B30 Standard Committee.

SECTION IX: REQUESTS FOR INTERPRETATION

The B30 Standard Committee will render an interpretation of the provisions of the B30 Standard. Such requests should be directed to

Secretary, B30 Standard Committee
ASME Codes and Standards
Two Park Avenue
New York, NY 10016-5990

Requests should be in the following format:

- Volume: Cite the designation and title of the volume.
Edition: Cite the applicable edition of the volume.
Subject: Cite the applicable paragraph number(s) and the relevant heading(s).
Question: Phrase the question as a request for an interpretation of a specific provision suitable for general understanding and use, not as a request for approval of a proprietary design or situation. Plans or drawings that explain the question may be submitted to clarify the question. However, they should not contain any proprietary names or information.

Upon receipt by the Secretary, the request will be forwarded to the relevant B30 Subcommittee for a draft response, which will then be subject to approval by the B30 Standard Committee prior to its formal issuance.

Interpretations to the B30 Standard will be published in the subsequent edition of the respective volume, and will be available online at <http://cstools.asme.org/>.

SECTION X: ADDITIONAL GUIDANCE

The equipment covered by the B30 Standard is subject to hazards that cannot be abated by mechanical means, but only by the exercise of intelligence, care, and common sense. It is therefore essential to have personnel involved in the use and operation of equipment who are competent, careful, physically and mentally qualified, and trained in the proper operation of the equipment and the handling of loads. Serious hazards include, but are not limited to, improper or inadequate maintenance, overloading, dropping or slipping of the load, obstructing the free passage of the load, and using equipment for a purpose for which it was not intended or designed.

The B30 Standard Committee fully realizes the importance of proper design factors, minimum or maximum dimensions, and other limiting criteria of wire rope or chain and their fastenings, sheaves, sprockets, drums, and similar equipment covered by the standard, all of



These factors are closely connected with safety. Sizes, strengths, and similar criteria are dependent on many different factors, often varying with the installation and uses.

These factors depend on

- (a) the condition of the equipment or material
- (b) the loads
- (c) the acceleration or speed of the ropes, chains, sheaves, sprockets, or drums
- (d) the type of attachments

(e) the number, size, and arrangement of sheaves or other parts

(f) environmental conditions causing corrosion or wear

(g) many variables that must be considered in each individual case

The requirements and recommendations provided in the volumes must be interpreted accordingly, and judgment used in determining their application.

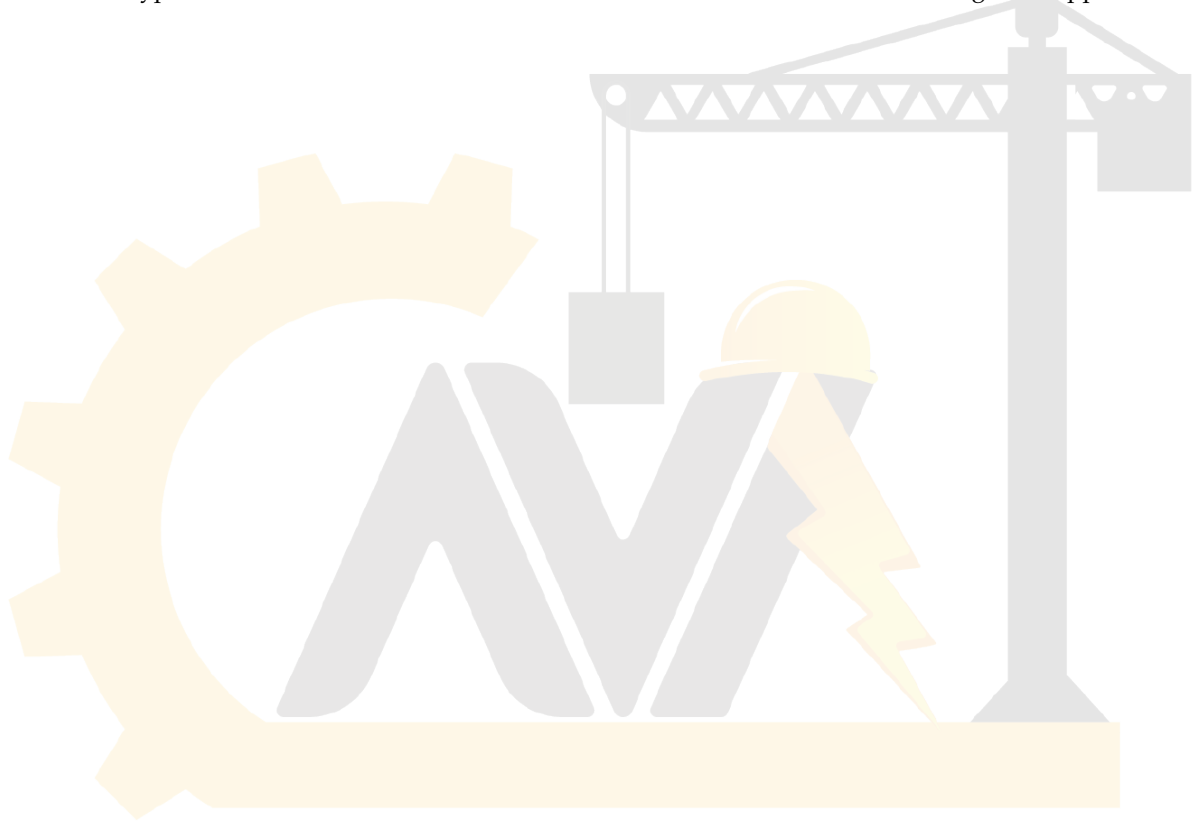

آریا ایمن آوات

ASME B30.26-2015 SUMMARY OF CHANGES

Following approval by the ASME B30 Committee and ASME, and after public review, ASME B30.26-2015 was approved by the American National Standards Institute on August 6, 2015.

ASME B30.26-2015 includes editorial changes, revisions, and corrections introduced in ASME B30.26-2010, as well as the following changes identified by a margin note, (15).

Page	Location	Change
ix–xi	B30 Standard Introduction	Updated
1	Chapter 26-0	Title revised
	Section 26-0.2	(1) Definition of <i>adjustable hardware</i> added (2) Definition of <i>designated person</i> deleted
2	Section 26-0.3	Added
	Section 26-0.4	Added
	Section 26-0.5	Added
3	26-1.1.2	Revised
	26-1.4.1	Subparagraph (b) revised
4–6	26-1.5.1	Revised
	26-1.5.2	Revised
	Section 26-1.8	(1) Revised (2) Paragraph 26-1.8.1 added and subsequent paragraphs redesignated
	26-1.9.1	Subparagraph (a) revised
	Figure 26-1.9.1-1	Revised
	26-1.9.4	Revised
7	26-2.1.2	Revised
	26-2.4.1	Subparagraph (c) revised
	Section 26-2.5	Revised
	26-2.6.2	Revised
8	Figure 26-2.1.1-2	Angular loading table added (2010 Errata)
11	Section 26-2.8	(1) Revised (2) Paragraph 26-2.8.1 added and subsequent paragraphs redesignated
	26-2.9.1	Subparagraph (a) revised
12	Figure 26-2.9.1-1	Revised
	26-2.9.4	Revised
14	26-3.1.2	Revised

Page	Location	Change
	Section 26-3.2	Revised
	Section 26-3.3	Subparagraph (b) revised
17, 18	26-3.4.1	Subparagraph (d) revised
	26-3.5.1	Revised
	26-3.5.2	Revised
	Section 26-3.8	(1) Revised (2) Paragraph 26-3.8.1 added and subsequent paragraphs redesignated
	26-3.9.4.1	Subparagraph (f) revised
19–22	Chapter 26-4	(1) Title revised (2) Master link subassemblies incorporated into text throughout (3) In Section 26-4.8, para. 26-4.8.1 added with subsequent paragraphs redesignated (4) Subparagraphs 26-4.9.4.1 (a), (f), and (g) revised (5) Paragraph 26-4.9.4.2 added and subsequent paragraph redesignated
	Figure 26-4.9.1-1	Revised
24	26-5.4.1	Subparagraph (b) revised
	26-5.5.1	Revised
	26-5.6.2	Revised
27	Figure 26-5.3-1	Editorially revised to include metric values
28	Section 26-5.8	(1) Revised (2) Paragraph 26-5.8.1 added and subsequent paragraphs redesignated
	26-5.9.1	Revised
29	26-5.9.4	Subparagraph (a) revised
30	26-6.1.2	Revised
	26-6.4.1	Subparagraph (b) revised
	26-6.5.1	Subparagraph (e) added
	26-6.6.2	Revised
34, 35	Section 26-6.8	(1) Revised (2) Paragraph 26-6.8.1 added and subsequent paragraphs redesignated
	26-6.9.1	Subparagraph (a) revised
	26-6.9.2	Subparagraph (d) revised
	26-6.9.4	Subparagraph (b) revised

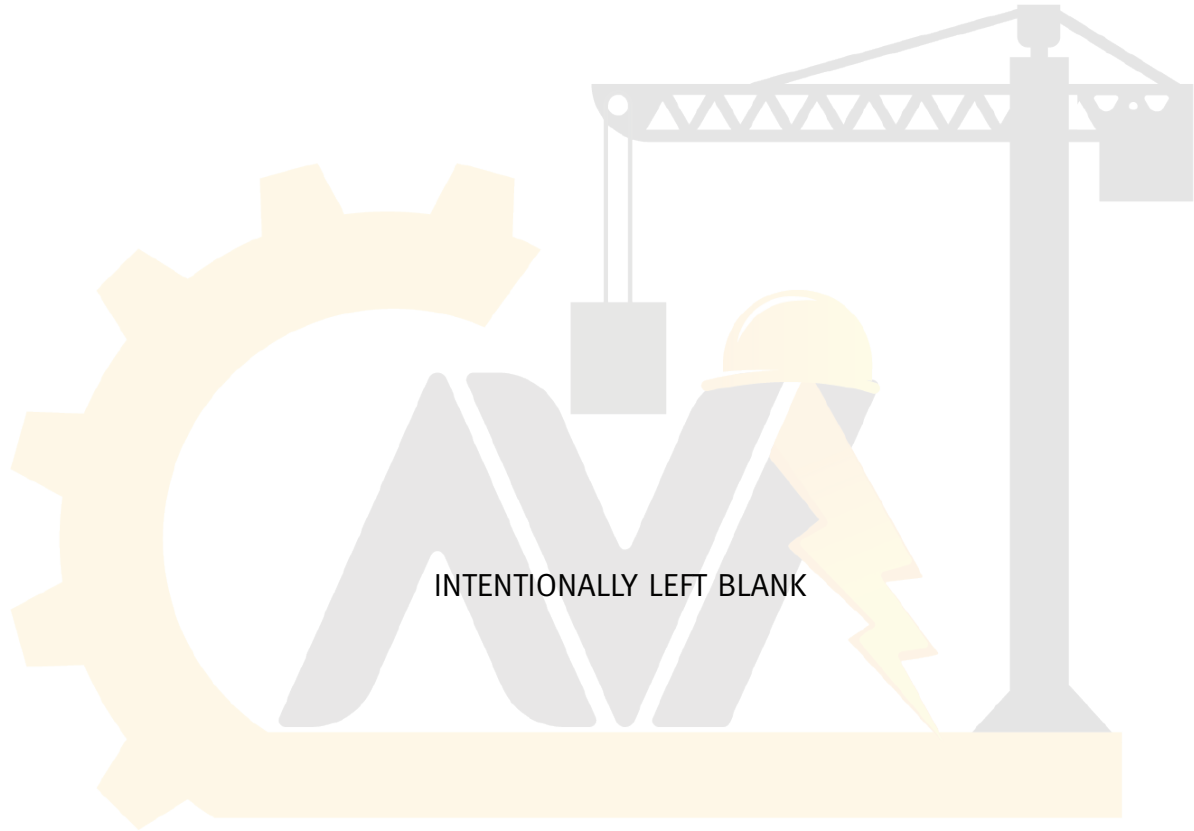

آریا ایمن آوات

RIGGING HARDWARE

Chapter 26-0 Scope, Definitions, Personnel Competence, Translations, and References

(15)

SECTION 26-0.1: SCOPE

Volume B30.26 includes provisions that apply to the construction, installation, operation, inspection, and maintenance of detachable rigging hardware used for load handling activities in conjunction with equipment described in other volumes of the B30 Standard. This hardware includes shackles, links, rings, swivels, turn-buckles, eyebolts, hoist rings, wire rope clips, wedge sockets, rigging blocks, and load-indicating devices. Detachable hardware used in applications other than those detailed in this Volume shall only be used in accordance with the recommendations of the manufacturer or a qualified person.

(15) SECTION 26-0.2: DEFINITIONS

abnormal operating conditions: environmental conditions that are unfavorable, harmful, or detrimental to or for the operation of a piece of detachable hardware, such as excessively high or low ambient temperatures, exposure to weather, corrosive fumes, dust laden or moisture laden atmospheres, and hazardous locations.

adjustable hardware: threaded detachable rigging hardware that is adjustable in length, orientation, or position by the user to handle a load.

angle of loading: the acute angle between horizontal and the leg of the rigging, often referred to as the horizontal angle (see Fig. 26-1.9.1-1).

NOTE: A stress multiplier produced by the angle of loading is also present when the rigging is used in nonvertical applications.

bow, shackle: the curved portion of the shackle body opposite the pin, often referred to as the bail, the body, the dee, or the bowl (see Fig. 26-1.9.4-1).

crane scale: see *load-indicating device*.

dead end: the section of wire rope that is not tensioned under load (see Figs. 26-3.1.1-1 and 26-3.1.1-2).

design factor: ratio between nominal or minimum breaking strength and rated load of the rigging hardware.

dynamometer: see *load-indicating device*.

ears, shackle: portion of the shackle body that supports the shackle pin (see Fig. 26-1.9.4-1).

hardware service

normal: service that involves use of loads at or below the rated load.

severe: service that involves normal service coupled with abnormal rigging or operating conditions.

special: service that involves operation, other than normal or severe, that is approved by a qualified person.

hitch, choker: a method of rigging a sling in which the sling is passed around the load, then through one loop eye, end fitting, or other device with the other loop eye or end fitting attached to the load handling device.

in-line loading: condition where the load is applied through the centerline of the rigging hardware at the intended bearing points.

jaw: a U-shaped, load-bearing connection designed for use with a removable pin (see Fig. 26-2.1.1-1).

LID: see *load-indicating device*.

line pull: the tension load in a rope entering a rigging block (see Fig. 26-5.3-1).

live end: the section of wire rope that is tensioned under load (see Figs. 26-3.1.1-1 and 26-3.1.1-2).

load-indicating device: a device that measures and displays applied load or force.

manufacturer: the entity responsible for the physical production of an item.

pin, shackle: a steel bolt made to span the two shackle ears (see Fig. 26-1.9.4-1).

primary load fitting: the fitting on a rigging block that carries the highest applied load during use (see Fig. 26-5.3-1).

proof load: the specific load applied in performance of the proof tests.

proof test: a nondestructive load test made to a specific multiple of the rated load of the rigging hardware.



n: a person who, by possession of a recognized degree, certificate or other qualification in an applicable field or certificate of professional standing or who, by extensive knowledge, training, and experience, has successfully demonstrated the ability to solve or resolve problems relating to the subject matter and work.

rated capacity: see *rated load*.

rated load: the maximum allowable working load established by the rigging hardware manufacturer. The terms *rated capacity* and *working load limit* are commonly used to describe rated load.

saddle: the base of a wire rope clip (see Fig. 26-3.1.1-1).

shackle: a U-shaped, load-bearing connector designed to be used with a removable pin (see Fig. 26-1.1.1-1).

shock load: a momentary increase in the force applied to lifting and/or load handling components caused by the sudden movement, shifting, or arresting of the load.

sling: an assembly used for lifting when connected to a lifting mechanism. The upper portion is connected to the lifting mechanism, and the lower supports the load, as described in the chapters of this Volume.

swivel hoist ring: a load-supporting device capable of pivoting and rotating, consisting of four components: a bolt, a swivel bearing, a bushing flange, and a load connection fitting, such as a bail or eye (see Fig. 26-2.1.1-4).

turnbuckle: an adjustable device consisting of three primary components: a body, a right-hand threaded end fitting, and a left-hand threaded end fitting (see Fig. 26-2.1.1-1).

wedge socket: an end fitting that terminates a wire rope by compressing the wire rope between a wedge and socket body (see Fig. 26-3.1.1-2).

wire rope clip: a fitting for clamping two parts of wire rope of the same diameter to each other by compressing the wire ropes between a saddle and a U-bolt or between two saddles (see Fig. 26-3.1.1-1).

double saddle type: wire rope clip using two saddles.

U-bolt type: wire rope clip using one saddle and a U-bolt.

working load limit (WLL): see *rated load*.

and capable to perform the functions as determined by the employer or employer's representative.

SECTION 26-0.4: TRANSLATIONS

(15)

(a) *Translation of Non-English Documentation Into English*

(1) The wording of written non-English safety information and manuals regarding use, inspection, and maintenance shall be translated into English by professional translation industry standards, which include, but are not limited to the following:

(-a) translation of the complete paragraph message, instead of word by word

(-b) grammatical accuracy

(-c) respectfulness of the source document content without omitting or expanding the text

(-d) accurate translation of the terminology

(-e) reflection of the level of sophistication of the original document

(2) The finished translation shall be verified for compliance with paras. 26-0.4(a)(1)(-a) through (a)(1)(-e) by a qualified person having an understanding of the technical content of the subject matter.

(3) Pictograms used to identify controls shall be described in the manuals, if required. The pictograms should comply with ISO 7000, or other recognized sources, if previously defined. The text of the description shall meet the criteria of paras. 26-0.4(a)(1) and (a)(2).

(b) Any non-English documentation provided in addition to English shall be translated and reviewed in accordance with the requirements listed above.

SECTION 26-0.5: REFERENCES

(15)

Within the text, references are made to the following publications, copies of which may be obtained from the publishers indicated:

ASME B30.9-2010, Slings

ASME B30.10-2009, Hooks

Publisher: The American Society of Mechanical Engineers (ASME), Two Park Avenue, New York, NY 10016-5990 (www.asme.org)

ISO 7000-2012, Graphic symbols for use on equipment-registered symbols

Publisher: International Organization for Standardization (ISO), Central Secretariat, Chemin de Blandonnet 8, Case Postale 401, 1214 Vernier, Geneva, Switzerland (www.iso.org)

(15) SECTION 26-0.3 PERSONNEL COMPETENCE

Persons performing the functions identified in this Volume shall, through education, training, experience, skill, and physical ability, as necessary, be competent

Chapter 26-1

Shackles – Selection, Use, and Maintenance

SECTION 26-1.0: SCOPE

This Chapter applies to shackles.

SECTION 26-1.1: TYPES AND MATERIALS

26-1.1.1 Types

(a) Body types covered are anchor, chain, and synthetic sling (see Fig. 26-1.1.1-1).

(b) Pin types covered are screw pin and bolt type (see Fig. 26-1.1.1-1).

(c) Shackles other than those detailed in this Chapter shall be used only in accordance with recommendations of the shackle manufacturer or a qualified person.

NOTE: Round pin shackles are not covered by the scope of this Volume, because they have limited application in lifting. They are only restrained by a cotter pin and may present a hazard in odd angle loading conditions.

(15) 26-1.1.2 Materials

The shackle shall have sufficient ductility to permanently deform before losing the ability to support the load at the temperatures the manufacturer has specified for use.

SECTION 26-1.2: DESIGN FACTOR

(a) The design factor for shackles up to and including a 150-ton (136-metric ton) rated load shall be a minimum of 5.

(b) The design factor for shackles over a 150-ton (136-metric ton) rated load shall be a minimum of 4.

SECTION 26-1.3: RATED LOADS

Rated load shall be in accordance with the recommendation of the shackle manufacturer. The terms *rated capacity* and *working load limit* are commonly used to describe rated load.

SECTION 26-1.4: PROOF TEST

26-1.4.1 Proof Test Requirements

(15)

(a) Shackles are not required to be proof tested unless specified by the purchaser.

(b) Proof tested shackles shall be inspected after the test for the conditions stated in para. 26-1.8.5.

26-1.4.2 Proof Load Requirements

(a) The proof load for a shackle up to and including a 150-ton (136-metric ton) rated load shall be a minimum

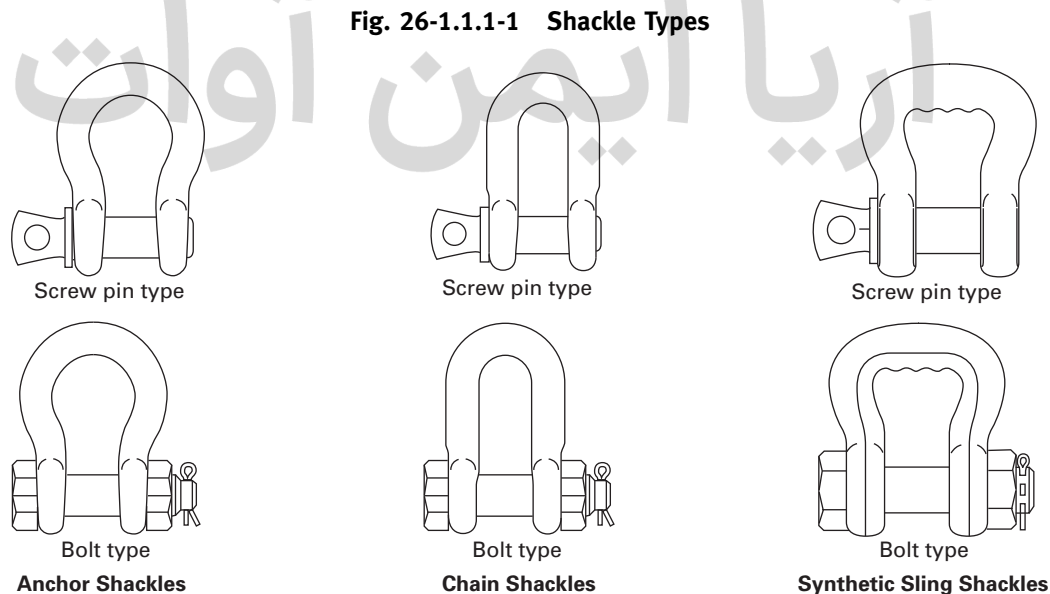



maximum of 2.2 times the rated load unless approved by the manufacturer.
The proof load for a shackle over a 150-ton (136-metric ton) rated load shall be a minimum of 1.33 and a maximum of 2 times the rated load unless approved by the manufacturer.

SECTION 26-1.5: IDENTIFICATION

(15) 26-1.5.1 Shackle Body Identification

Each shackle body shall have durable markings by the manufacturer to show

- (a) name or trademark of manufacturer
- (b) rated load
- (c) size

(15) 26-1.5.2 Shackle Pin Identification

Each shackle pin shall have durable markings by the manufacturer to show

- (a) name or trademark of manufacturer
- (b) grade, material type, or load rating

26-1.5.3 Maintenance of Identification

Shackle identification should be maintained by the user so as to be legible throughout the life of the shackle.

SECTION 26-1.6: EFFECTS OF ENVIRONMENT

26-1.6.1 Temperature

When shackles are to be used at temperatures above 400°F (204°C) or below -40°F (-40°C), the shackle manufacturer or a qualified person should be consulted.

26-1.6.2 Chemically Active Environments

The strength of shackles can be affected by chemically active environments, such as caustic or acidic substances or fumes. The shackle manufacturer or a qualified person should be consulted before shackles are used in chemically active environments.

SECTION 26-1.7: TRAINING

Shackle users shall be trained in the selection, inspection, cautions to personnel, effects of environment, and rigging practices as covered by this Chapter.

(15) SECTION 26-1.8: INSPECTION, REPAIR, AND REMOVAL

26-1.8.1 General

All inspections shall be performed by a designated person. Any deficiencies identified shall be examined and a determination made by a qualified person as to whether they constitute a hazard.

26-1.8.2 Initial Inspection

Prior to use, all new, altered, modified, or repaired shackles shall be inspected to verify compliance with the applicable provisions of this Chapter. Written records are not required.

26-1.8.3 Frequent Inspection

(a) A visual inspection shall be performed each shift before the shackle is used. Rigging hardware in semi-permanent and inaccessible locations where frequent inspections are not feasible shall have periodic inspections performed.

(b) Conditions such as those listed in para. 26-1.8.5 or any other condition that may result in a hazard shall cause the shackle to be removed from service. Shackles shall not be returned to service until approved by a qualified person.

(c) Written records are not required.

26-1.8.4 Periodic Inspection

(a) A complete inspection of the shackle shall be performed. The shackle shall be examined for conditions such as those listed in para. 26-1.8.5 and a determination made as to whether they constitute a hazard.

(b) *Periodic Inspection Frequency*

(1) Periodic inspection intervals shall not exceed 1 yr. The frequency of periodic inspections should be based on

- (-a) frequency of use
- (-b) severity of service conditions
- (-c) nature of lifting or load handling activities
- (-d) experience gained on the service life of shackles used in similar circumstances

(2) Guidelines for the time intervals are

- (-a) normal service — yearly
- (-b) severe service — monthly to quarterly
- (-c) special service — as recommended by a qualified person

(c) Written records are not required.

26-1.8.5 Removal Criteria

Shackles shall be removed from service if conditions such as the following are present and shall only be returned to service when approved by a qualified person:

- (a) missing or illegible identification
- (b) indications of heat damage, including weld spatter or arc strikes
- (c) excessive pitting or corrosion
- (d) bent, twisted, distorted, stretched, elongated, cracked, or broken load-bearing components
- (e) excessive nicks or gouges
- (f) a 10% reduction of the original or catalog dimension at any point around the body or pin
- (g) incomplete pin engagement

Fig. 26-1.9.1-1 Angle of Loading (Shackles)

(15)

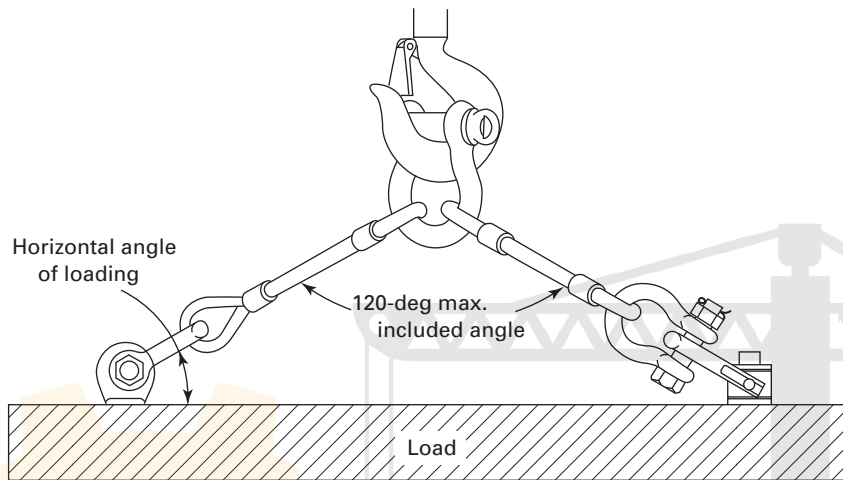

Horizontal Angle, deg	Stress Multiplier
90	1.000
60	1.155
45	1.414
30	2.000

- (h) excessive thread damage
- (i) evidence of unauthorized welding or modification
- (j) other conditions, including visible damage, that cause doubt as to the continued use of the shackle

26-1.8.6 Repairs and Modifications

- (a) Repairs, alterations, or modifications shall be as specified by the shackle manufacturer or a qualified person.
- (b) Replacement parts, such as pins, shall meet or exceed the original equipment manufacturer's specifications.

SECTION 26-1.9: OPERATING PRACTICES

(15) 26-1.9.1 Shackle Selection

(a) Shackles having suitable characteristics for the type of sling, load, hitch, angle of loading, and environment shall be selected in accordance with the recommendations of the shackle manufacturer or a qualified person.

NOTE: The angle of loading affects the stress in the shackle. As the horizontal angle decreases, the stress increases in the shackle (see Fig. 26-1.9.1-1).

- (b) The rated load of the shackle shall not be exceeded.
- (c) Shackles that appear to be damaged shall not be used until inspected and accepted as usable under Section 26-1.8.

26-1.9.2 Cautions to Personnel

- (a) All portions of the human body shall be kept from between the shackle, the load, and any other rigging during the lifting or load handling activities.
- (b) Personnel should stand clear of the suspended load.
- (c) Personnel should stand clear of rigging when it is under tension.
- (d) Personnel shall not ride the shackle.

26-1.9.3 Storage and Work Environments

- (a) Shackles should be stored in an area where they will not be subjected to damage, corrosive action, or extreme heat.
- (b) If extreme temperatures or chemically active environments are involved, the guidance provided in para. 26-1.6.1 or 26-1.6.2 shall be followed.

26-1.9.4 Rigging Practices

(15)

- (a) The screw pin threads shall be fully engaged and tight, and the shoulder should be in contact with the shackle body (see Fig. 26-1.9.4-1).
- (b) If a shackle is designed for a cotter pin, the cotter pin shall be used and maintained in good working condition.
- (c) Contact with sharp edges that could damage the shackle should be avoided.
- (d) Shock loading should be avoided.
- (e) The load applied to the shackle should be centered in the bow of the shackle to prevent side loading of the shackle.

The sling legs should not be applied to the shackle. If the shackle is to be side loaded, the rated load shall be reduced according to Fig. 26-1.9.4-2 or the recommendations of the manufacturer or a qualified person.

(h) Screw pin shackles shall not be rigged in a manner that would cause the pin to unscrew.

(i) For long-term installations, bolt-type shackles should be used; if screw pin-type shackles are used, the pin shall be secured from rotation or loosening.

(j) Shackles should not be dragged on an abrasive surface.

(k) Multiple slings in the body of a shackle shall not exceed 120-deg included angle (see Fig. 26-1.9.1-1).

(l) When a shackle is used in a choker hitch, the pin shall be connected to the choking eye of the sling.

Fig. 26-1.9.4-1 Typical Shackle Components

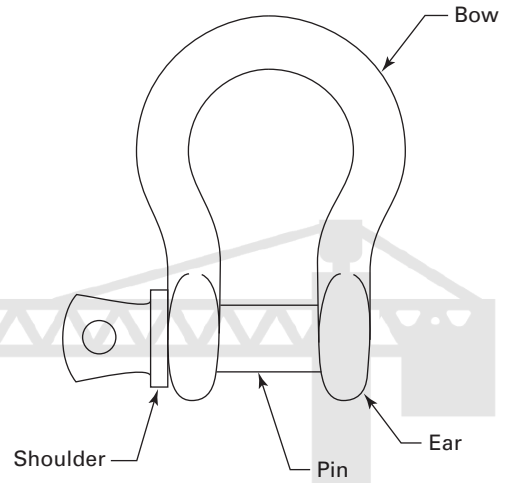
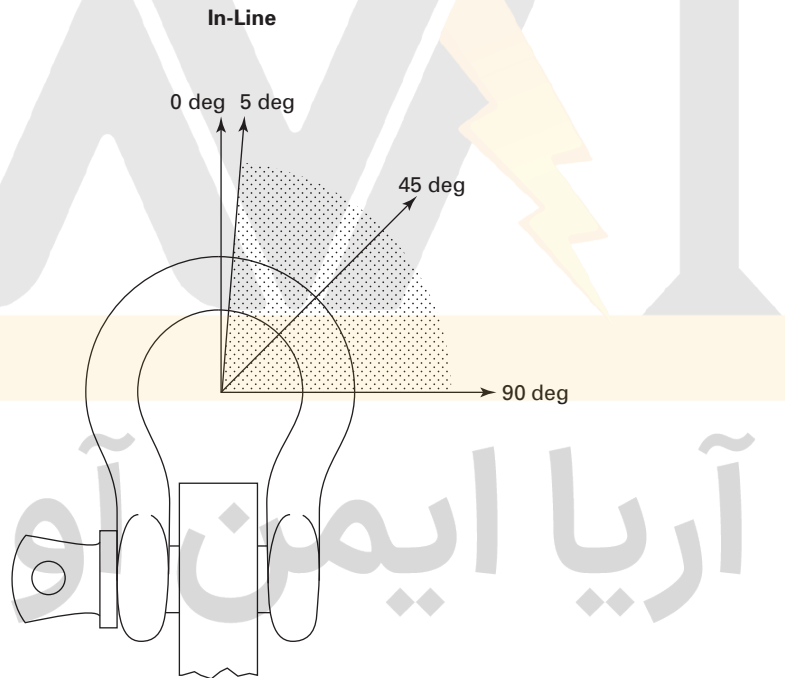

Fig. 26-1.9.4-2 Side Loading



Side Loading Angle, deg

In-line (0) to 5
6 to 45
46 to 90
Over 90

% Rate Load Reduction

None
30%
50%
Not recommended to load in this condition. Consult manufacturer or qualified person.

Chapter 26-2

Adjustable Hardware — Selection, Use, and Maintenance

SECTION 26-2.0: SCOPE

This Chapter applies to adjustable hardware, including turnbuckles, eyebolts, eye nuts, and swivel hoist rings.

SECTION 26-2.1: TYPES AND MATERIALS

26-2.1.1 Types

- (a) Turnbuckles, including open and pipe body types with hook, eye, or jaw end fittings (see Fig. 26-2.1.1-1).
- (b) Eyebolts, including shoulder nut, nonshoulder nut, nonshoulder machinery, and shoulder machinery types (see Fig. 26-2.1.1-2).
- (c) Eye nuts (see Fig. 26-2.1.1-3).
- (d) Swivel hoist rings (see Fig. 26-2.1.1-4).
- (e) Adjustable hardware other than those detailed in this Chapter shall be used only in accordance with recommendations of the manufacturer or a qualified person.

(15) 26-2.1.2 Materials

The hardware, excluding bushings and bearings, shall have sufficient ductility to permanently deform before losing the ability to support the load at the temperatures the manufacturer has specified for use.

SECTION 26-2.2: DESIGN FACTOR

The design factor for adjustable hardware shall be a minimum of 5.

SECTION 26-2.3: RATED LOADS

Rated load shall be in accordance with the recommendation of the hardware manufacturer. The terms *rated capacity* and *working load limit* are commonly used to describe rated load.

SECTION 26-2.4: PROOF TEST

(15) 26-2.4.1 Proof Test Requirements

- (a) New adjustable hardware is not required to be proof tested unless specified by the purchaser.
- (b) All repairs to swivel hoist rings with bushings or bearings should be proof tested.
- (c) Proof tested adjustable hardware shall be inspected after the test for the conditions stated in para. 26-2.8.5.

26-2.4.2 Proof Load Requirements

The proof load shall be a minimum of 2 times the rated load.

SECTION 26-2.5: IDENTIFICATION

26-2.5.1 Turnbuckle, Eyebolt, and Eye Nut Identification

Each turnbuckle, eyebolt, and eye nut shall be durably marked by the manufacturer to show

- (a) name or trademark of manufacturer
- (b) size or rated load
- (c) grade for alloy eyebolts

26-2.5.2 Swivel Hoist Ring Identification

Each swivel hoist ring shall be durably marked by the manufacturer to show

- (a) name or trademark of manufacturer
- (b) rated load
- (c) torque value

26-2.5.3 Maintenance of Identification

Turnbuckle, eyebolt, eye nut, and swivel hoist ring identification should be maintained by the user so as to be legible throughout the life of the hardware.

SECTION 26-2.6: EFFECTS OF ENVIRONMENT

26-2.6.1 Temperature

(a) When adjustable hardware, excluding swivel hoist rings and carbon steel eyebolts, is to be used at temperatures above 400°F (204°C) or below -40°F (-40°C), the hardware manufacturer or a qualified person should be consulted.

(b) When swivel hoist rings are to be used at temperatures above 400°F (204°C) or below -20°F (-29°C), the hardware manufacturer or a qualified person should be consulted.

(c) When carbon steel eyebolts are to be used at temperatures above 275°F (135°C) or below 30°F (-1°C), the hardware manufacturer or a qualified person should be consulted.

26-2.6.2 Chemically Active Environments

The strength of adjustable hardware can be affected by chemically active environments such as caustic or acidic substances or fumes. The adjustable hardware

(15)

(15)

Fig. 26-2.1.1-1 Turnbuckles

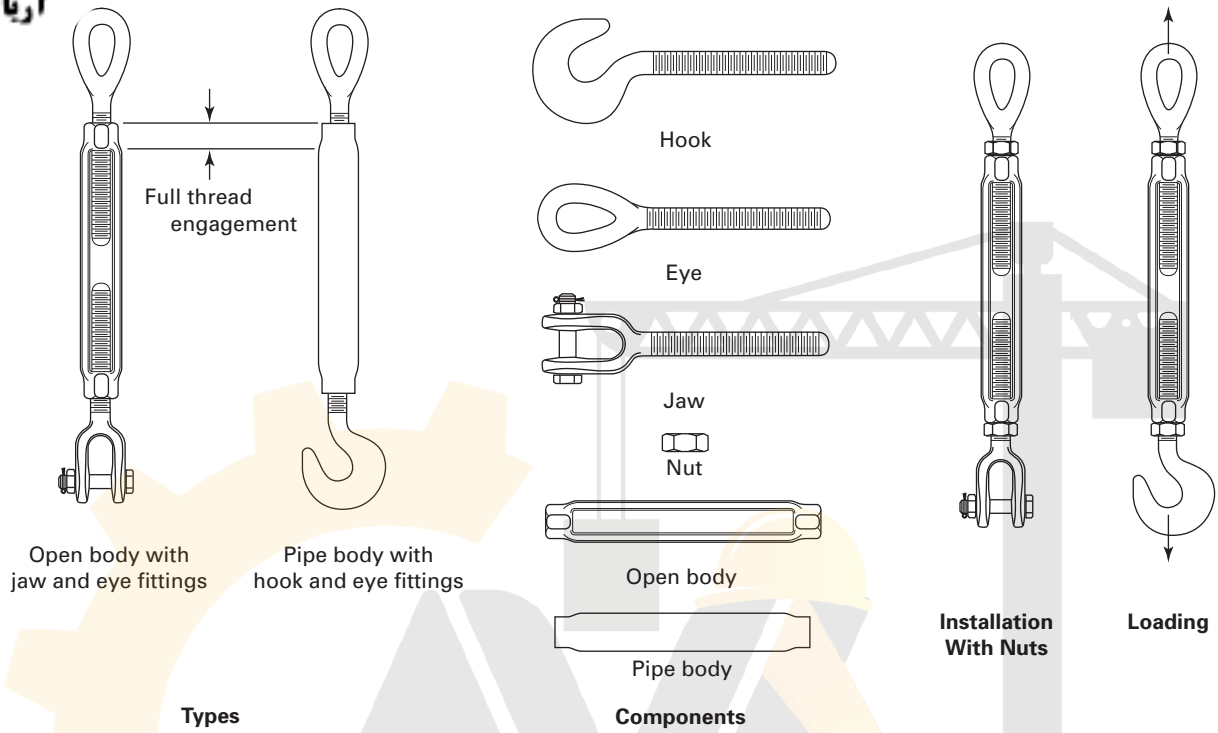

(15)

Fig. 26-2.1.1-2 Eyebolts

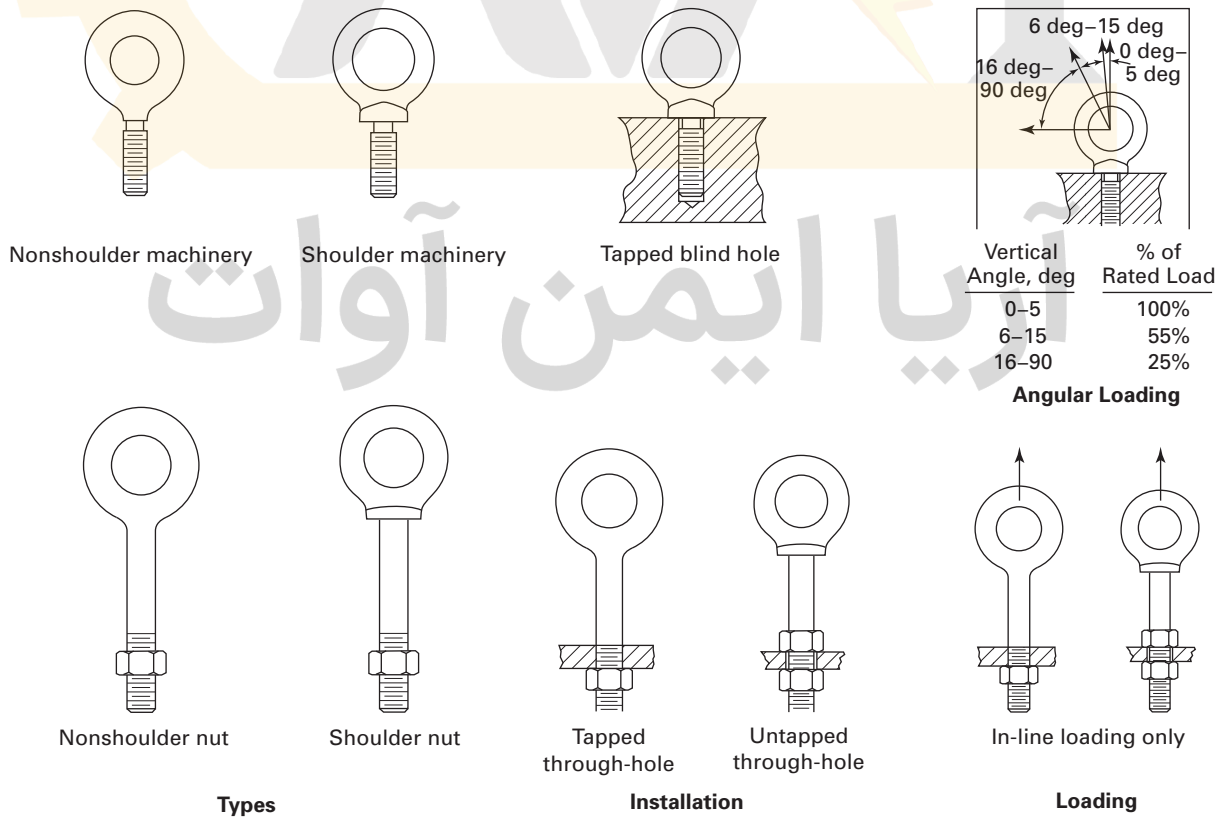
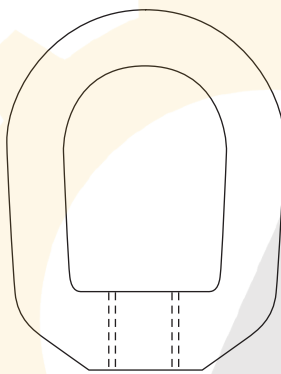
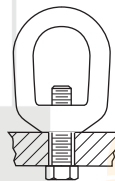

Fig. 26-2.1.1-3 Eye Nuts



Typical

Types



Through-hole no nut



Through-hole top nut

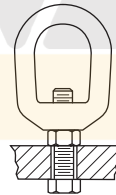

Through-hole
bottom nut

Installation

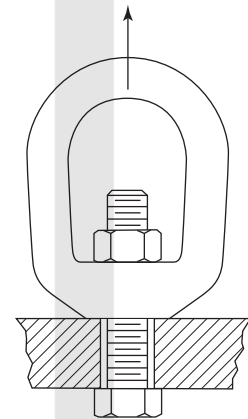

In-line loading only

Loading

آریا ایمن آوات

Fig. 26-2.1.1-4 Swivel Hoist Rings

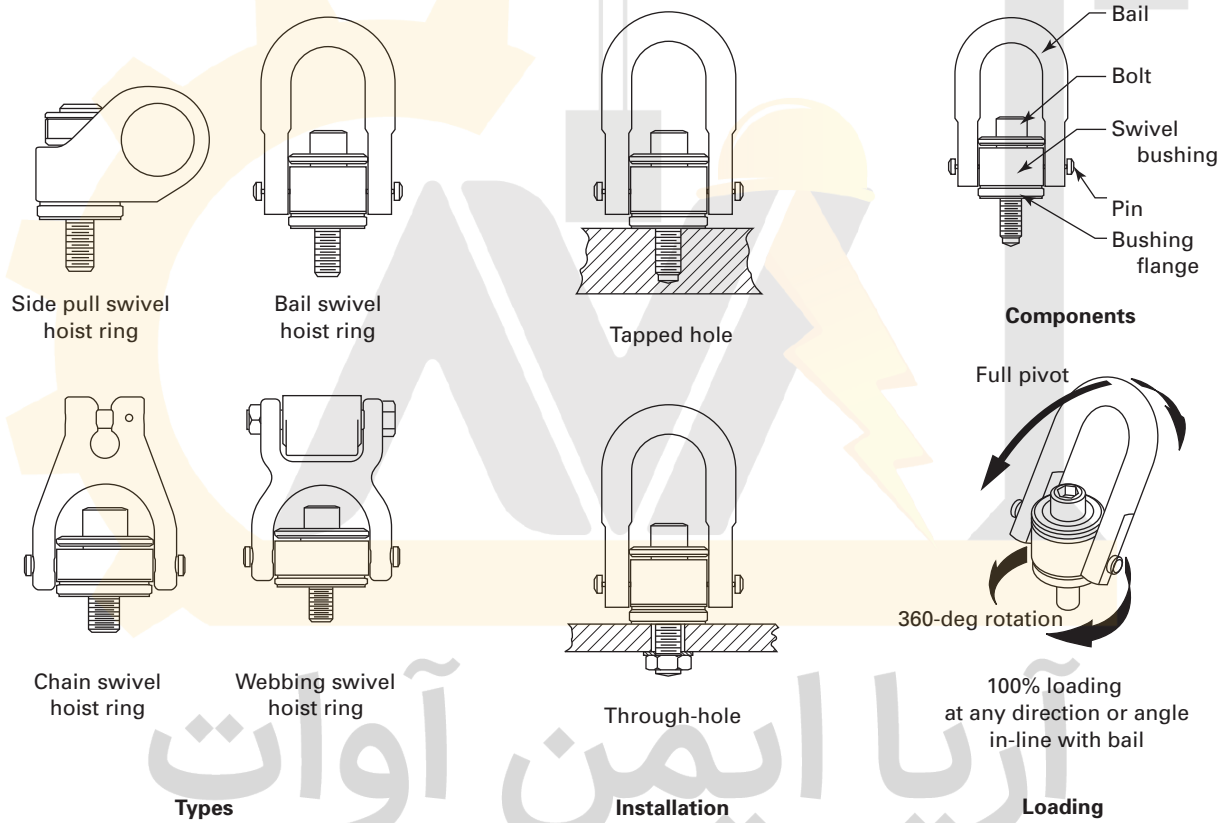



manufacturer or a qualified person should be consulted for use in chemically active environments.

SECTION 26-2.7: TRAINING

Adjustable hardware users shall be trained in the selection, inspection, cautions to personnel, effects of environment, and rigging practices as covered by this Chapter.

(15) SECTION 26-2.8: INSPECTION, REPAIR, AND REMOVAL

26-2.8.1 General

All inspections shall be performed by a designated person. Any deficiencies identified shall be examined and a determination made by a qualified person as to whether they constitute a hazard.

26-2.8.2 Initial Inspection

Prior to use, all new, altered, modified, or repaired adjustable hardware shall be inspected to verify compliance with the applicable provisions of this Chapter. Written records are not required.

26-2.8.3 Frequent Inspection

(a) A visual inspection shall be performed each shift before the adjustable hardware is used. Rigging hardware in semi-permanent and inaccessible locations where frequent inspections are not feasible shall have periodic inspections performed.

(b) Conditions such as those listed in para. 26-2.8.5 or any other condition that may result in a hazard shall cause the adjustable hardware to be removed from service. Adjustable hardware shall not be returned to service until approved by a qualified person.

(c) Written records are not required.

26-2.8.4 Periodic Inspection

(a) A complete inspection of the adjustable hardware shall be performed. The adjustable hardware shall be examined for conditions such as those listed in para. 26-2.8.5 and a determination made as to whether they constitute a hazard.

(b) *Periodic Inspection Frequency*

(1) Periodic inspection intervals shall not exceed 1 yr. The frequency of periodic inspections should be based on

- (-a) frequency of use
- (-b) severity of service conditions
- (-c) nature of lifting or load handling activities
- (-d) experience gained on the service life of adjustable hardware used in similar circumstances

(2) Guidelines for the time intervals are

- (-a) normal service — yearly
- (-b) severe service — monthly to quarterly

(-c) special service — as recommended by a qualified person

(c) Written records are not required.

26-2.8.5 Removal Criteria

Adjustable hardware shall be removed from service if conditions such as the following are present and shall only be returned to service when approved by a qualified person:

- (a) missing or illegible identification
- (b) indications of heat damage, including weld spatter or arc strikes
- (c) excessive pitting or corrosion
- (d) bent, twisted, distorted, stretched, elongated, cracked, or broken load-bearing components
- (e) excessive nicks or gouges
- (f) a 10% reduction of the original or catalog dimension at any point
- (g) excessive thread damage or wear
- (h) evidence of unauthorized welding or modification
- (i) for swivel hoist rings, lack of the ability to freely rotate or pivot
- (j) other conditions, including visible damage, that cause doubt as to continued use

26-2.8.6 Repairs and Modifications

(a) Repairs, alterations, or modifications shall be as specified by the adjustable hardware manufacturer or a qualified person.

(b) Replacement parts, including nuts, pins, and bolts, shall meet or exceed the original equipment manufacturer's specifications.

SECTION 26-2.9: OPERATING PRACTICES

26-2.9.1 Adjustable Hardware Selection

(15)

(a) Adjustable hardware having suitable characteristics for the type of load, hitch, angle of loading, and environment shall be selected in accordance with the recommendations of the adjustable hardware manufacturer or a qualified person.

NOTES:

- (1) The angle of loading affects the stress in the hardware. As the horizontal angle decreases, the stress increases (see Fig. 26-2.9.1-1).
- (2) The integrity of the load where the adjustable hardware attaches is the responsibility of the end user.

(b) The rated load of the adjustable hardware shall not be exceeded.

(c) Adjustable hardware that appears to be damaged shall not be used until inspected and accepted as usable per Section 26-2.8.

26-2.9.2 Cautions to Personnel

(a) All portions of the human body shall be kept from between the rigging hardware, the load, and any other rigging during lifting or load handling activities.

Fig. 26-2.9.1-1 Angle of Loading (Adjustable Hardware)

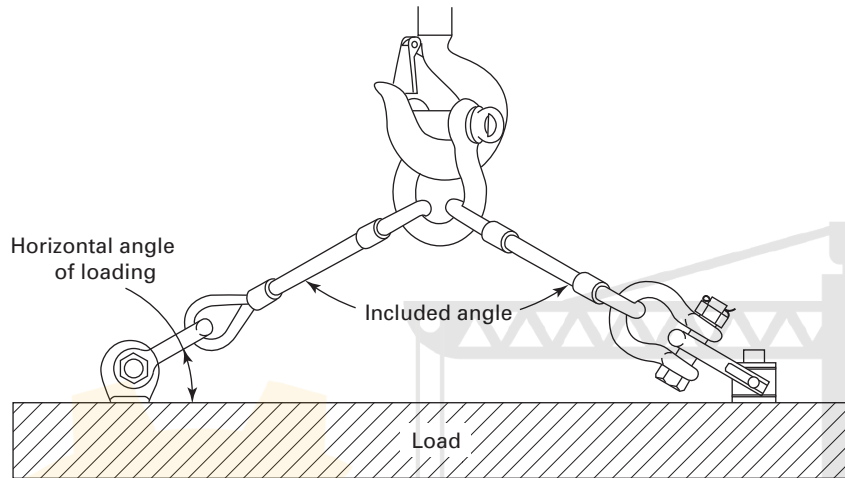

Horizontal Angle, deg	Stress Multiplier
90	1.000
60	1.155
45	1.414
30	2.000

(b) Personnel should stand clear of the suspended load.

(c) Personnel should stand clear of rigging when it is under tension.

(d) Personnel shall not ride rigging hardware.

26-2.9.3 Storage and Work Environments

(a) Adjustable hardware should be stored in an area where it will not be subjected to damage, corrosive action, or extreme heat.

(b) If extreme temperatures or chemically active environments are involved, the guidance provided in para. 26-2.6.1 or 26-2.6.2 shall be followed.

(15) 26-2.9.4 Rigging Practices

26-2.9.4.1 Turnbuckles

(a) Turnbuckle end-fitting threads shall be fully engaged in the body threads.

NOTE: Pipe bodies conceal the length of thread engagement. Verify full engagement before loading (see Fig. 26-2.1.1-1).

(b) Components, including pins, bolts, nuts, or cotter pins used with jaw ends, shall be in good working condition prior to use.

(c) If locking nuts (see Fig. 26-2.1.1-1) are used, they shall be compatible with the threads of the turnbuckle end.

(d) Contact with obstructions that could damage or bend the turnbuckle should be avoided.

(e) Shock loading should be avoided.

(f) The load applied to the turnbuckle should be in line and in tension.

(g) Turnbuckles should not be side loaded.

(h) Turnbuckles should be rigged or secured to prevent unscrewing during lifting or load handling activities.

(i) For long-term installations, turnbuckles shall be secured to prevent unscrewing.

(j) Turnbuckles should not be dragged on an abrasive surface.

(k) Turnbuckles should be adjusted with a properly sized wrench, used on the wrench flats of the turnbuckle body.

26-2.9.4.2 Eyebolts

(a) Eyebolts should be tightened or otherwise secured against rotation during lifting or load handling activities.

(b) When used in a tapped blind hole, the effective thread length shall be at least $1\frac{1}{2}$ times the diameter of the bolt for engagement in steel (see Fig. 26-2.1.1-2). For other thread engagements or engagement in other materials, contact the eyebolt manufacturer or a qualified person.

(c) When used in a tapped through-hole of less than one diameter thickness, a nut shall be used under the load and fully engaged and tightened securely against the load (see Fig. 26-2.1.1-2).

(d) When used in an untapped through-hole, the nut under the load shall be fully engaged. If the eyebolt is not shouldered to the load, a second nut on top of the load should be used where possible (see Fig. 26-2.1.1-2).

(e) Eyebolts not shouldered to the load shall only be used for in-line loads (see Fig. 26-2.1.1-2).



ly shoulder eyebolts shall be used for angular loading. When used for angular loading, the shoulder shall be flush and securely tightened against the load.

The working load limit (WLL) must be reduced as shown in Fig. 26-2.1.1-2.

(g) When using eyebolts for angular load handling, the plane of the eyebolts shall be aligned with the direction of pull. Steel flat washers may be used under the shoulder to position the plane of the eye.

(h) Eyebolts shall be in good working condition prior to use.

(i) Shock loading should be avoided.

26-2.9.4.3 Eye Nuts

(a) Eye nuts should have full thread engagement and should be secured against rotation during lifting or load handling activities.

(b) The threads of the eye nut shall be fully engaged (see Fig. 26-2.1.1-3).

(c) Eye nuts shall only be used for in-line loads (see Fig. 26-2.1.1-3).

(d) The plane of the eye may be positioned with a flat washer(s) or locknut.

(e) Components shall be in good working condition prior to use.

(f) Shock loading should be avoided.

26-2.9.4.4 Swivel Hoist Rings

(a) When used in a threaded hole, the effective thread length shall be $1\frac{1}{2}$ times the diameter of the bolt for

steel (see Fig. 26-2.1.1-4). For other thread engagements or engagement in other materials, contact the swivel hoist ring manufacturer or a qualified person.

(b) When used in a through-hole application, a nut and washer shall be used. The washer and nut shall be in accordance with the swivel hoist ring manufacturer's recommendations. The nut shall be fully engaged (see Fig. 26-2.1.1-4).

(c) The bushing flange (see Fig. 26-2.1.1-4) shall fully contact the load surface.

(d) Spacers or washers shall not be used between the bushing flange and mounting surface of the load.

(e) The swivel hoist ring shall be tightened to the torque specifications of the manufacturer.

(f) The swivel hoist ring shall be free to rotate and pivot without interference during load handling activities (see Fig. 26-2.1.1-4).

(g) The load applied to the swivel hoist ring shall be centered in the bail to prevent side loading.

(h) Any attached load handling component shall be narrower than the inside width of the bail to avoid spreading (see Fig. 26-2.1.1-4).

(i) Components shall be in good working condition prior to use.

(j) Ensure that the swivel hoist ring WLL meets or exceeds the anticipated angular rigging tension (see Fig. 26-2.9.1-1).

(k) Shock loading should be avoided.

آریا ایمن آوات

Chapter 26-3

Compression Hardware – Selection, Use, and Maintenance

SECTION 26-3.0: SCOPE

This Chapter applies to compression hardware, including forged wire rope clips and wedge sockets.

SECTION 26-3.1: TYPES, MATERIALS, AND ASSEMBLY

26-3.1.1 Types

(a) Wire rope clip types covered are U-bolt and double saddle (see Fig. 26-3.1.1-1).

(b) Wedge sockets (see Fig. 26-3.1.1-2).

(c) Compression hardware other than those detailed in this Chapter shall be used only in accordance with recommendations of the manufacturer or a qualified person.

recommended by the manufacturer or a qualified person.

26-3.1.4 Assembly – Wedge Sockets

(a) The wedge socket shall be assembled as recommended by the manufacturer or a qualified person.

(b) Before installing a wedge socket on plastic coated or plastic impregnated wire rope, consult the wedge socket manufacturer, wire rope manufacturer, or a qualified person.

(c) The live end of the wire rope in the wedge socket cavity shall be in alignment with the socket's pin (see Fig. 26-3.1.1-2).

(d) The assembler shall match the proper wedge with the socket for the wire rope to be installed.

NOTE: Wedges shall not be interchanged between different manufacturers' sockets or models.

(e) The length of the dead-end tail of the wire rope shall be as required by the manufacturer or a qualified person.

(f) The dead-end tail of the wire rope extending beyond the wedge socket shall be secured in a manner recommended by the wedge socket manufacturer or a qualified person (see Fig. 26-3.1.1-2).

(g) The dead end of the wire rope shall not be secured to the live end of the wire rope such that it restricts the movement of the live end (see Fig. 26-3.1.1-2).

(h) After assembly, the connection shall be loaded to fully seat the wedge before use.

SECTION 26-3.2: DESIGN FACTOR

(15)

Due to the nature of the design and use, wire rope clips and wedge sockets do not have a conventional design factor. Wire rope clips and wedge sockets shall be designed to have an 80% minimum termination efficiency based on the wire rope published minimum breaking force with which they are used.

SECTION 26-3.3: RATED LOADS

(15)

The rated load for wire rope assemblies using compression hardware is based on the following factors:

(a) wire rope minimum breaking force

(b) 80% minimum termination efficiency

(c) design factor of the wire rope application

(15) 26-3.1.2 Materials

(a) Wire rope clip materials shall be of sufficient strength such that failure of the wire rope will occur before failure of the wire rope clip at the temperatures the manufacturer has specified for use. Saddles shall be forged steel.

(b) Wedge socket materials shall be of sufficient strength such that failure of the wire rope will occur before failure of the wedge socket at the temperatures the manufacturer has specified for use.

26-3.1.3 Assembly – Wire Rope Clips

(a) Before installing a wire rope clip on plastic coated or plastic impregnated wire rope, consult the wire rope clip manufacturer, wire rope manufacturer, or a qualified person.

(b) For U-bolt clips used to create end terminations, the saddle shall be placed on the live end of the wire rope, with the U-bolt on the dead-end side (see Fig. 26-3.1.1-1).

(c) At least the minimum number of clips as recommended by the manufacturer or a qualified person shall be used.

(d) The spacing and turn-back should be as recommended by the manufacturer or a qualified person.

(e) The wire rope clip shall be tightened to the torque recommended by the manufacturer or a qualified person.

(f) After assembly, the connection shall be loaded to at least the expected working load. After unloading, wire rope clips shall then be retightened to the torque

Fig. 26-3.1.1-1 Wire Rope Clips

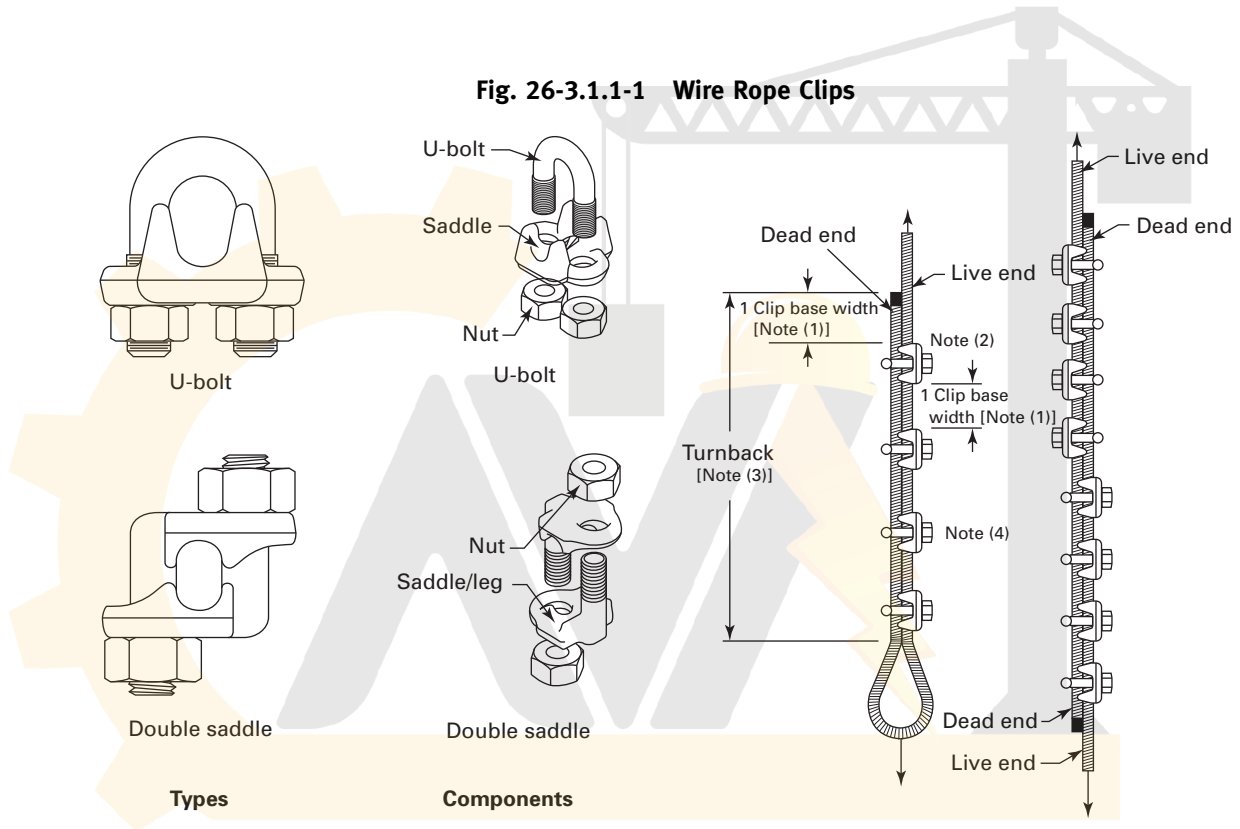

GENERAL NOTE: Correct number of clips for wire rope size shall be used.

NOTES:

- (1) Correct spacing of clips should be used.
- (2) Correct orientation of saddle on live end shall be observed.
- (3) Correct turnback length should be used.
- (4) Correct torque on nuts shall be applied.

Fig. 26-3.1.1-2 Wedge Sockets

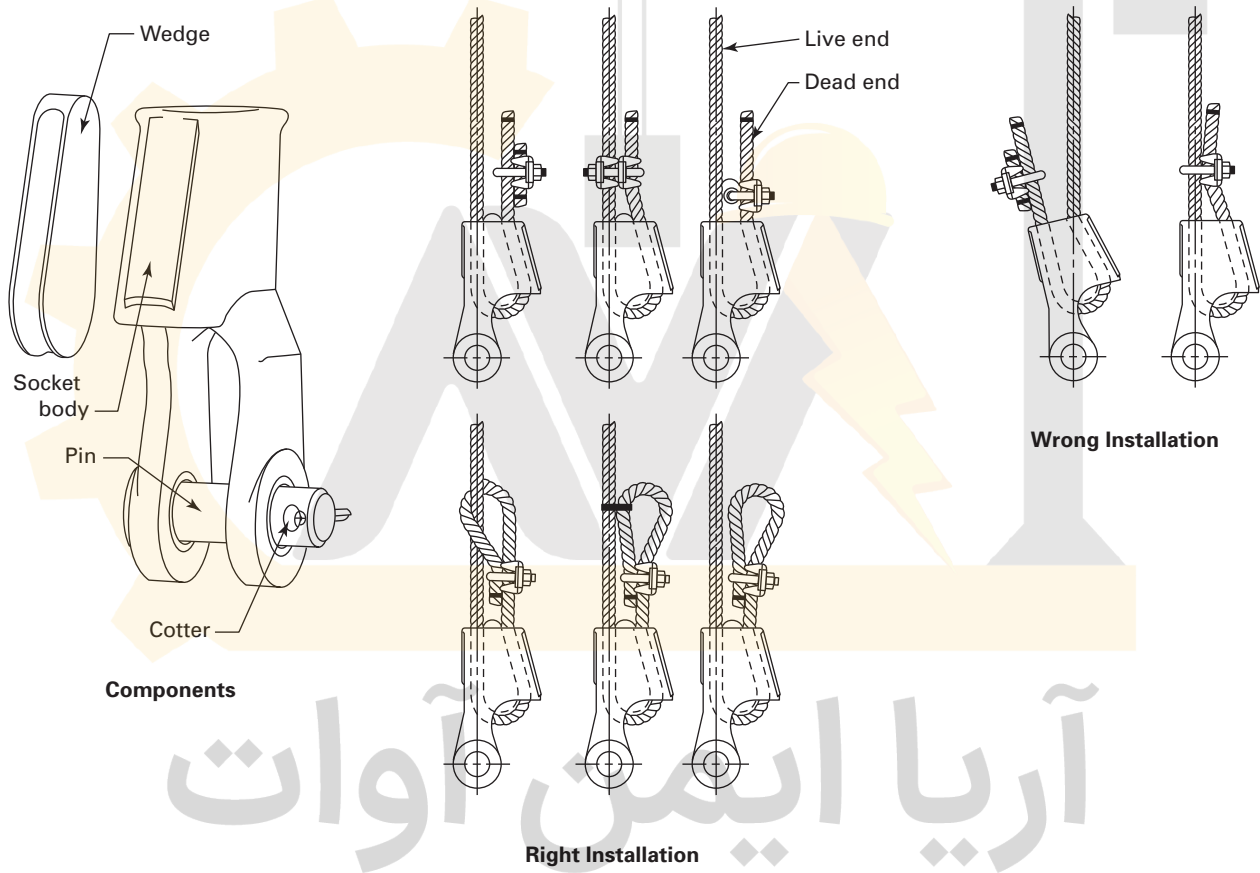



26-3.4: PROOF TEST

26-3.4.1 Proof Test Requirements

(a) Compression hardware is not required to be proof tested unless specified by the purchaser.

(b) If required, the proof test shall be applied to the wedge socket or the connection made by the wire rope clips after the assembly is complete.

(c) After proof testing, wire rope clips on a finished assembly shall be retightened to the torque recommended by the wire rope clip manufacturer or a qualified person.

(d) Proof tested compression hardware shall be inspected after the test for the conditions stated in para. 26-3.8.5.

26-3.4.2 Proof Load Requirements

The proof load shall be a minimum of 40%, but not exceed 50%, of the wire rope minimum breaking force, unless approved by the compression hardware manufacturer or a qualified person.

SECTION 26-3.5: IDENTIFICATION

(15) 26-3.5.1 Wire Rope Clip Saddle Identification

Each wire rope clip saddle shall have durable markings by the manufacturer to show

- (a) name or trademark of manufacturer
- (b) size

(15) 26-3.5.2 Wedge Socket Identification

Each wedge socket body and wedge shall have durable markings by the manufacturer to show

- (a) name or trademark of manufacturer
- (b) size
- (c) model, if required to match wedge to body

26-3.5.3 Maintenance of Identification

Compression hardware identification should be maintained by the user so as to be legible throughout the life of the hardware.

SECTION 26-3.6: EFFECTS OF ENVIRONMENT

26-3.6.1 Temperature

(a) When wire rope clips are to be used at temperatures above 400°F (204°C) or below -40°F (-4°C), the wire rope clip manufacturer or a qualified person should be consulted.

(b) When wedge sockets are to be used at temperatures above 400°F (204°C) or below -4°F (-20°C), the wedge socket manufacturer or a qualified person should be consulted.

26-3.6.2 Chemically Active Environments

The strength of compression hardware can be affected by chemically active environments, such as caustic or

acidic substances or fumes. The compression hardware manufacturer or a qualified person should be consulted before compression hardware is used in chemically active environments.

SECTION 26-3.7: TRAINING

Compression hardware users shall be trained in the selection, inspection, cautions to personnel, effects of environment, and rigging practices as covered by this Chapter.

SECTION 26-3.8: INSPECTION, REPAIR, AND REMOVAL

(15)

26-3.8.1 General

All inspections shall be performed by a designated person. Any deficiencies identified shall be examined and a determination made by a qualified person as to whether they constitute a hazard.

26-3.8.2 Initial Inspection

Prior to use, all new, altered, modified, or repaired compression hardware shall be inspected to verify compliance with the applicable provisions of this Chapter. Written records are not required.

26-3.8.3 Frequent Inspection

(a) A visual inspection shall be performed each shift before the compression hardware is used. Rigging hardware in semi-permanent and inaccessible locations where frequent inspections are not feasible shall have periodic inspections performed.

(b) Conditions such as those listed in para. 26-3.8.5, or any other condition that may result in a hazard, shall cause the compression hardware to be removed from service. Compression hardware shall not be returned to service until approved by a qualified person.

(c) Written records are not required.

26-3.8.4 Periodic Inspection

(a) A complete inspection of the compression hardware shall be performed. The compression hardware shall be examined for conditions such as those listed in para. 26-3.8.5 and a determination made as to whether they constitute a hazard.

(b) *Periodic Inspection Frequency*

(1) Periodic inspection intervals shall not exceed 1 yr. The frequency of periodic inspections should be based on

- (-a) frequency of use
- (-b) severity of service conditions
- (-c) nature of lifting or load handling activities
- (-d) experience gained on the service life of compression hardware used in similar circumstances



- elines for the time intervals are
- (a) normal service — yearly
 - (b) severe service — monthly to quarterly
 - (c) special service — as recommended by a qualified person
- (c) Written records are not required.

26-3.8.5 Removal Criteria

Compression hardware shall be removed from service if conditions such as the following are present and shall only be returned to service when approved by a qualified person:

- (a) missing or illegible identification
- (b) indications of heat damage, including weld spatter or arc strikes
- (c) excessive pitting or corrosion
- (d) bent, twisted, distorted, stretched, elongated, cracked, or broken components
- (e) excessive nicks or gouges
- (f) a 10% reduction of the original or catalog dimension at any point
- (g) evidence of unauthorized welding or modification
- (h) unauthorized replacement components
- (i) insufficient number of wire rope clips
- (j) improperly tightened wire rope clips
- (k) indications of damaged wire rope
- (l) indications of wire rope slippage
- (m) improper assembly or other conditions, including visible damage, that cause doubt as to continued use

26-3.8.6 Repairs and Modifications

- (a) Repairs, alterations, or modifications shall be as specified by the compression hardware manufacturer or a qualified person.
- (b) Replacement parts shall meet or exceed the original compression hardware manufacturer's specifications.

SECTION 26-3.9: OPERATING PRACTICES

26-3.9.1 Compression Hardware Selection

- (a) Compression hardware having suitable characteristics for the type of application and environment shall be selected in accordance with the recommendations of the compression hardware manufacturer or a qualified person.
- (b) The rated load shall not be exceeded (see Section 26-3.3).

- (c) Compression hardware that appears to be damaged shall not be used until inspected and accepted as usable under Section 26-3.8.

26-3.9.2 Cautions to Personnel

- (a) All portions of the human body shall be kept from between the load and any other rigging during lifting or load handling activities.
- (b) Personnel should stand clear of the suspended load.
- (c) Personnel should stand clear of rigging when it is under tension.
- (d) Personnel shall not ride rigging hardware.

26-3.9.3 Storage and Work Environments

- (a) Compression hardware should be stored in an area where it will not be subjected to damage, corrosive action, or extreme heat.
- (b) If extreme temperatures or chemically active environments are involved, the guidance provided in para. 26-3.6.1 or 26-3.6.2 shall be followed.

26-3.9.4 Rigging Practices

26-3.9.4.1 Wire Rope Clips

- (a) Assemble wire rope clips in accordance with para. 26-3.1.3.
- (b) Wire rope clips should not be in contact with the load or any obstruction during lifting or load handling activities.
- (c) Shock loading should be avoided.
- (d) Rigging using wire rope clips should not be dragged on an abrasive surface.
- (e) When wire rope clips are applied to join two lengths of wire rope in an in-line splice, the requirements of para. 26-3.1.3 shall be followed (see Fig. 26-3.1.1-1).
- (f) Wire rope clips should not be used to fabricate slings. See ASME B30.9 for specific exceptions.

26-3.9.4.2 Wedge Sockets

- (a) Assemble wedge sockets in accordance with para. 26-3.1.4.
- (b) The wedge sockets should not be side loaded.
- (c) Contact with sharp edges that could damage the wedge socket should be avoided.
- (d) Shock loading should be avoided.
- (e) Impacts can dislodge the wedge from the body and should be avoided.
- (f) Rigging using wedge sockets should not be dragged on an abrasive surface.

(15)

Chapter 26-4

Links, Master Link Subassemblies, Rings, and Swivels

SECTION 26-4.0: SCOPE

This Chapter applies to links, master link subassemblies, rings, and swivels.

SECTION 26-4.1: TYPES AND MATERIALS

26-4.1.1 Types

(a) Links, master link subassemblies, and rings, including oblong, round and pear shapes (see Fig. 26-4.1.1-1).

(b) Swivels, including eye-and-eye and eye-and-jaw types used for positioning (see Fig. 26-4.1.1-2).

(c) Links, master link subassemblies, rings, and swivels other than those detailed in this Chapter shall be used only in accordance with recommendations of the manufacturer or a qualified person.

26-4.1.2 Materials

Links, master link subassemblies, rings, and swivels shall have sufficient ductility to permanently deform before losing the ability to support the load at the temperatures the manufacturer has specified for use.

SECTION 26-4.2: DESIGN FACTOR

The design factor for links, master link subassemblies, rings, and swivels shall be a minimum of 5.

SECTION 26-4.3: RATED LOADS

Rated load shall be in accordance with the recommendation of the link, master link subassembly, ring, or swivel manufacturer. The terms *rated capacity* and *working load limit* are commonly used to describe rated load.

Fig. 26-4.1.1-1 Links and Rings

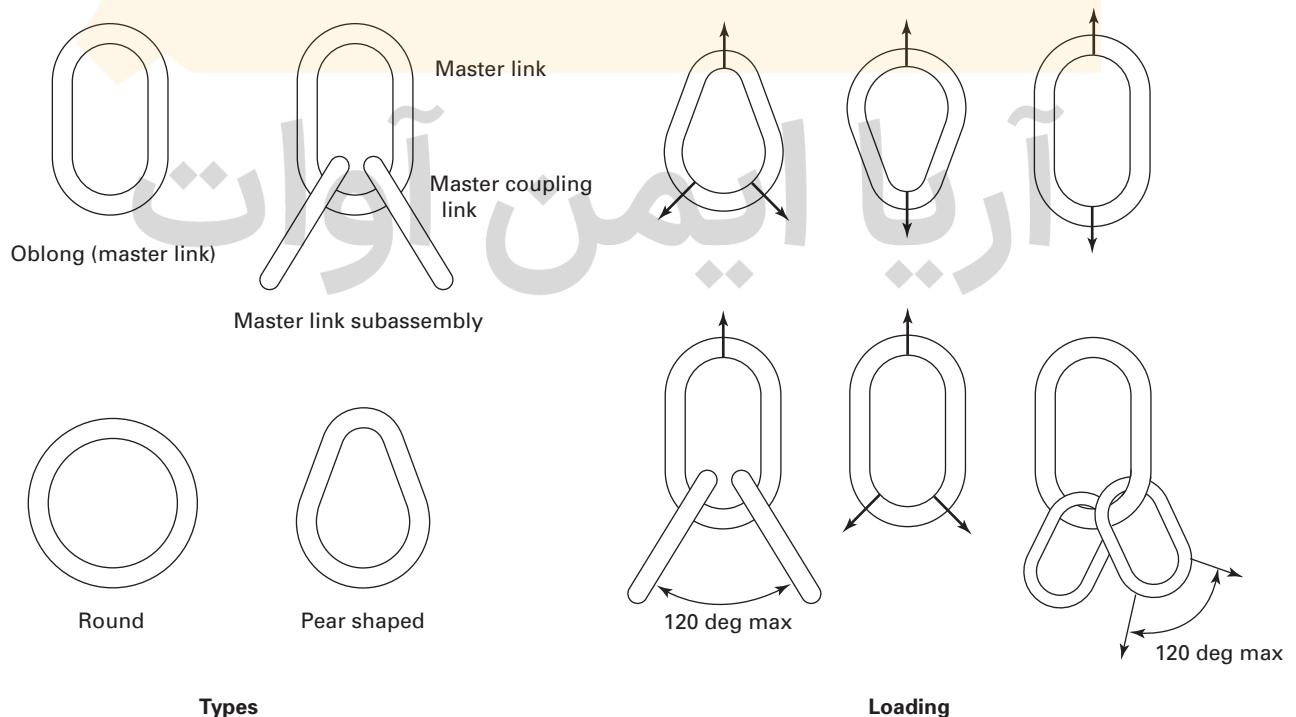
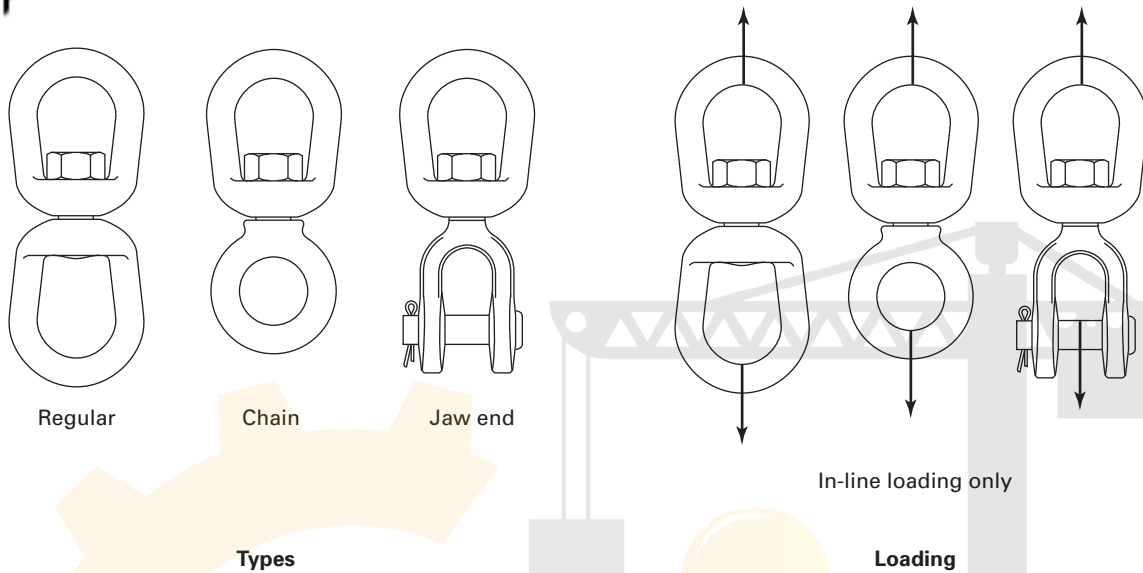

Fig. 26-4.1.1-2 Swivels



SECTION 26-4.4: PROOF TEST

26-4.4.1 Proof Test Requirements

(a) Prior to initial use, welded links, welded rings, and master link subassemblies shall be proof tested by the manufacturer or a qualified person.

(b) All other links, rings, and swivels are not required to be proof tested unless specified by the purchaser.

(c) Proof tested links, master link subassemblies, rings, and swivels shall be inspected after the test for the conditions stated in para. 26-4.8.5.

26-4.4.2 Proof Load Requirements

(a) The proof load for links, rings, and swivels shall be a minimum of 2 times the rated load.

(b) The proof load for master link subassemblies are

(1) each master coupling link shall be tested at the rated load of the master link subassembly

(2) the master link shall be tested at 2 times the rated load of the master link subassembly

SECTION 26-4.5: IDENTIFICATION

26-4.5.1 Links, Master Link Subassemblies, Rings, and Swivels Identification

Each link, master link subassembly, ring, and swivel shall be durably marked by the manufacturer to show

(a) name or trademark of manufacturer

(b) size or rated load

(c) grade, if required to identify rated load

26-4.5.2 Maintenance of Identification

Link, master link subassembly, ring, and swivel identification should be maintained by the user so as to be legible throughout the life of the hardware.

SECTION 26-4.6: EFFECTS OF ENVIRONMENT

26-4.6.1 Temperature

(a) When steel links, master link subassemblies, rings, or swivels are to be used at temperatures above 400°F (204°C) or below -40°F (-40°C), the link, master link subassembly, ring, and swivel manufacturer or a qualified person should be consulted.

(b) For links, master link subassemblies, rings, or swivels made from other materials, consult the manufacturer or a qualified person.

26-4.6.2 Chemically Active Environments

The strength of links, master link subassemblies, rings, and swivels can be affected by chemically active environments, such as caustic or acidic substances or fumes. The link, master link subassembly, ring, or swivel manufacturer or a qualified person shall be consulted before use in chemically active environments.

SECTION 26-4.7: TRAINING

Link, master link subassembly, ring, and swivel users shall be trained in the selection, inspection, cautions to personnel, effects of environment, and rigging practices as covered by this Chapter.



26-4.8: INSPECTION, REPAIR, AND REMOVAL

26-4.8.1 General

All inspections shall be performed by a designated person. Any deficiencies identified shall be examined and a determination made by a qualified person as to whether they constitute a hazard.

26-4.8.2 Initial Inspection

Prior to use, all new, altered, modified, or repaired links, master link subassemblies, rings, and swivels shall be inspected to verify compliance with the applicable provisions of this Chapter. Written records are not required.

26-4.8.3 Frequent Inspection

(a) A visual inspection shall be performed each shift before the links, master link subassemblies, rings, and swivels are used. Rigging hardware in semi-permanent and inaccessible locations where frequent inspections are not feasible shall have periodic inspections performed.

(b) Conditions such as those listed in para. 26-4.8.5, or any other condition that may result in a hazard, shall cause the hardware to be removed from service. Links, master link subassemblies, rings, and swivels shall not be returned to service until approved by a qualified person.

(c) Written records are not required.

26-4.8.4 Periodic Inspection

(a) A complete inspection of the links, master link subassemblies, rings, and swivels shall be performed. The hardware shall be examined for conditions such as those listed in para. 26-4.8.5 and a determination made as to whether they constitute a hazard.

(b) *Periodic Inspection Frequency*

(1) Periodic inspection intervals shall not exceed 1 yr. The frequency of periodic inspections should be based on

- (-a) frequency of use
- (-b) severity of service conditions
- (-c) nature of lifting or load handling activities
- (-d) experience gained on the service life of hardware used in similar circumstances

(2) Guidelines for the time intervals are

- (-a) normal service — yearly
- (-b) severe service — monthly to quarterly
- (-c) special service — as recommended by a qualified person

(c) Written records are not required.

26-4.8.5 Removal Criteria

Links, master link subassemblies, rings, and swivels shall be removed from service if conditions such as the

following are present and shall only be returned to service when approved by a qualified person:

- (a) missing or illegible identification
- (b) indications of heat damage, including weld spatter or arc strikes
- (c) excessive pitting or corrosion
- (d) bent, twisted, distorted, stretched, elongated, cracked, or broken load-bearing components
- (e) excessive nicks or gouges
- (f) a 10% reduction of the original or catalog dimension at any point
- (g) evidence of unauthorized welding or modification
- (h) for swivels, lack of the ability to freely rotate when not loaded
- (i) for swivels, loose or missing nuts, bolts, cotter pins, snap rings, or other fasteners and retaining devices
- (j) other conditions, including visible damage that cause doubt as to continued use

26-4.8.6 Repairs and Modifications

(a) Repairs, alterations, or modifications shall be as specified by the link, master link subassembly, ring, or swivel manufacturer or a qualified person.

(b) Replacement parts shall meet or exceed the original equipment manufacturer's specifications.

SECTION 26-4.9: OPERATING PRACTICES

26-4.9.1 Links, Master Link Subassemblies, Rings, and Swivels Selection

(a) Links, master link subassemblies, rings, and swivels having suitable characteristics for the type of load, hitch, angle of loading, and environment shall be selected in accordance with the recommendations of the hardware manufacturer or a qualified person.

NOTE: The angle of loading affects the load on the links, master link subassemblies, rings, and swivels. As the horizontal angle decreases, the effective load increases (see Fig. 26-4.9.1-1).

(b) The rated load of the links, master link subassemblies, rings, and swivels shall not be exceeded.

(c) Links, master link subassemblies, rings, and swivels that appear to be damaged shall not be used until inspected and accepted as usable under para. 26-4.8.

26-4.9.2 Cautions to Personnel

(a) All portions of the human body shall be kept from between the links, master link subassemblies, rings, and swivels, the load, and any other rigging during lifting or load handling activities.

(b) Personnel should stand clear of the suspended load.

3. 26-4.9.1-1 Angle of Loading (Links, Master Link Subassemblies, Rings, and Swivels)

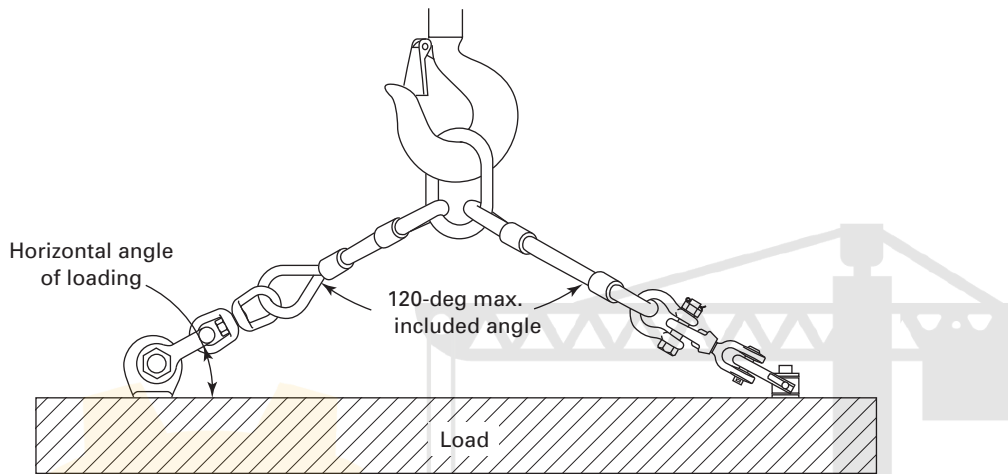

Horizontal Angle, deg	Stress Multiplier
90	1.000
60	1.155
45	1.414
30	2.000

(c) Personnel should stand clear of rigging when it is under tension.

(d) Personnel shall not ride links, master link subassemblies, rings, and swivels.

26-4.9.3 Storage and Work Environments

(a) Links, master link subassemblies, rings, and swivels should be stored in an area where they will not be subjected to damage, corrosive action, or extreme temperatures.

(b) If extreme temperatures or chemically active environments are involved, the guidance provided in para. 26-4.6.1 or 26-4.6.2 shall be followed.

26-4.9.4 Rigging Practices

26-4.9.4.1 Links and Rings

(a) Alterations or modifications shall comply with para. 26-4.8.6(a).

(b) Contact with obstructions that could damage the link or ring should be avoided.

(c) Shock loading should be avoided.

(d) Links and rings should not be dragged on an abrasive surface.

(e) The link or ring shall be of the proper shape and size to ensure that it seats properly in the hook, lifting device, or rigging hardware.

(f) Multiple slings or rigging hardware gathered in a link or ring shall not exceed a 120-deg included angle, unless approved by a qualified person (see Fig. 26-4.9.1-1).

(g) The horizontal angle of loading shall not be less than 30 deg, unless approved by a qualified person (see Fig. 26-4.9.1-1).

26-4.9.4.2 Master Link Subassemblies

(a) Alterations or modifications shall comply with para. 26-4.8.6(a).

(b) Contact with obstructions that could damage the master link subassembly should be avoided.

(c) Shock loading should be avoided.

(d) Master link subassembly should not be dragged on an abrasive surface.

(e) The master link subassembly shall be of the proper shape and size to ensure that it seats properly in the hook, lifting device, or rigging hardware.

(f) Multiple slings or rigging hardware gathered in a master coupling link shall not exceed a 120-deg included angle, unless approved by a qualified person (see Fig. 26-4.1.1-1).

(g) The master coupling links gathered in a master link shall not exceed a 120-deg included angle, unless approved by a qualified person (see Fig. 26-4.1.1-1).

(h) The horizontal angle of loading shall not be less than 30 deg, unless approved by a qualified person (see Fig. 26-4.9.1-1).

(i) Nonsymmetrical loads require an analysis by a qualified person to prevent overloading of any master coupling link.

(j) No single component shall be overloaded.

26-4.9.4.3 Swivels

(a) Swivels are positioning hardware and are not intended to be rotated under load.



Swivels shall only be used for in-line loads (see 4.1.1-2).

(c) Components shall be maintained in good working condition.

(d) Alterations or modifications shall comply with para. 26-4.8.6(a).

(e) Shock loading should be avoided.

(f) Swivels shall be of the proper shape and size to ensure that they seat properly in the hook, lifting device, or rigging hardware.

(g) Contact with obstructions that could damage the swivel should be avoided.

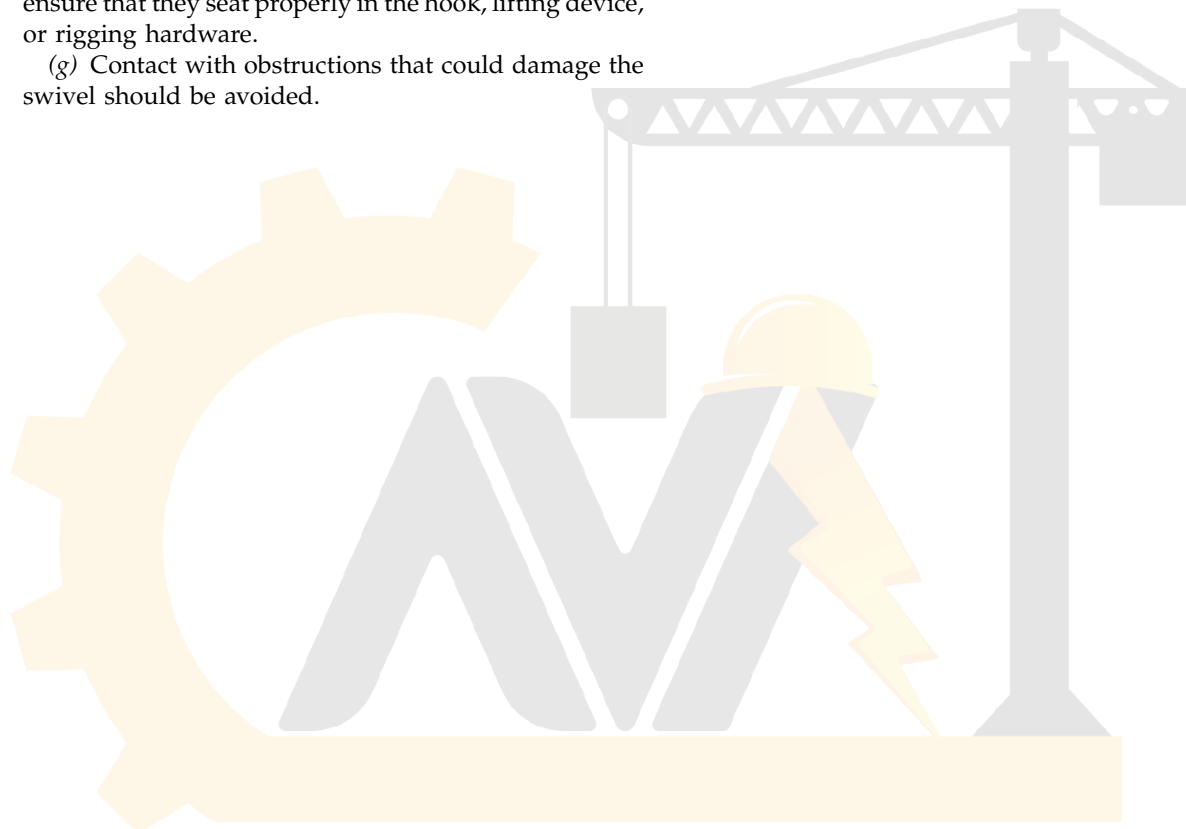

آريا ايمن آوات

Chapter 26-5

Rigging Blocks – Selection, Use, and Maintenance

SECTION 26-5.0: SCOPE

This Chapter applies to rigging blocks. Crane blocks are covered by crane type under other ASME B30 Volumes.

SECTION 26-5.1: TYPES AND MATERIALS

26-5.1.1 Types

(a) Types include tackle, utility, rolling, and snatch blocks (see Fig. 26-5.1.1-1).

(b) Load fittings on rigging blocks may include hooks, eyes, swivels, yokes, bails, shackles, and pins (see Fig. 26-5.1.1-2).

(c) Rigging blocks other than those detailed in this Chapter shall be used in accordance with recommendations of the manufacturer or a qualified person.

26-5.1.2 Materials

(a) The rigging block shall have sufficient ductility to permanently deform before losing the ability to support the load at the temperatures that the manufacturer has specified for use.

(b) The shell or side plates shall be metal, wood, or synthetic.

(c) The sheave(s) shall be metal or synthetic.

(d) The load-bearing straps and fitting(s) shall be made of metal.

SECTION 26-5.2: DESIGN FACTOR

The design factor for rigging blocks shall be a minimum of 4.

SECTION 26-5.3: RATED LOADS

Rated load shall be in accordance with the recommendation of the rigging block manufacturer. The terms *rated capacity* and *working load limit* are commonly used to describe rated load.

NOTE: The block rated load is the maximum load applied to the primary load fitting, not the line pull (see Fig. 26-5.3-1).

SECTION 26-5.4: PROOF TEST

(15) 26-5.4.1 Proof Test Requirements

(a) Rigging blocks are not required to be proof tested unless specified by the purchaser.

(b) Proof tested rigging blocks shall be inspected after the test for the conditions stated in para. 26-5.8.5.

26-5.4.2 Proof Load Requirements

The proof load for a rigging block shall be a minimum of 1.5 and a maximum of 2 times the rated load unless approved by the manufacturer or a qualified person.

SECTION 26-5.5: IDENTIFICATION

26-5.5.1 Marking

(15)

Each rigging block shall be durably marked by the manufacturer to show

(a) name or trademark of manufacturer

(b) rated load

(c) rope size(s)

26-5.5.2 Maintenance of Identification

Rigging block identification should be maintained by the user so as to be legible throughout the life of the block.

SECTION 26-5.6: EFFECTS OF ENVIRONMENT

26-5.6.1 Temperature

When rigging blocks are to be used at temperatures above 150°F (66°C) or below 0°F (-18°C), the rigging block manufacturer or a qualified person should be consulted.

26-5.6.2 Chemically Active Environments

(15)

Chemically active environments, such as caustic or acidic substances or fumes, can affect the strength, operating characteristics, or both of rigging blocks. The rigging block manufacturer or a qualified person should be consulted when rigging blocks are used in chemically active environments.

SECTION 26-5.7: TRAINING

Rigging block users shall be trained in the selection, inspection, cautions to personnel, effects of environment, and rigging practices as covered by this Chapter.

Fig. 26-5.1.1-1 Rigging Block Types

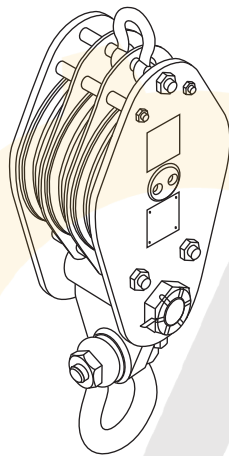

Tackle Block

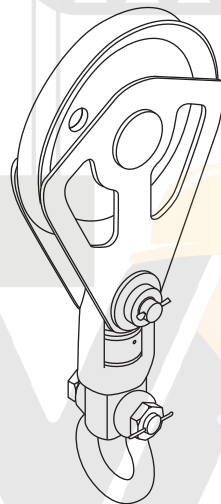

Rolling Block

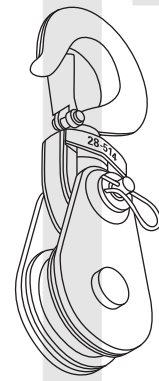

Snatch Block

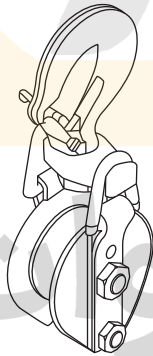

Utility Block



Snatch Block

Fig. 26-5.1.1-2 Typical Rigging Block Components

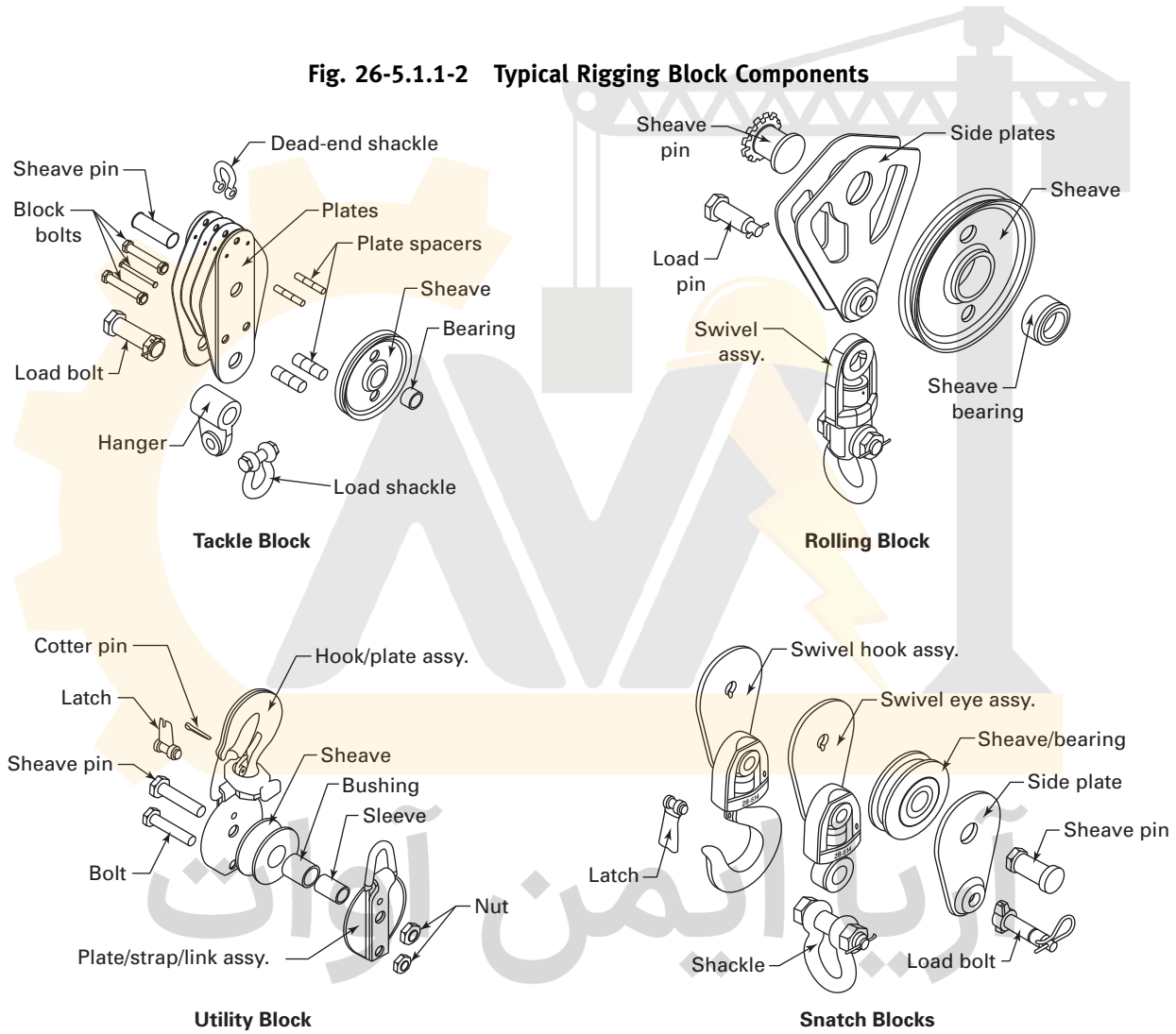
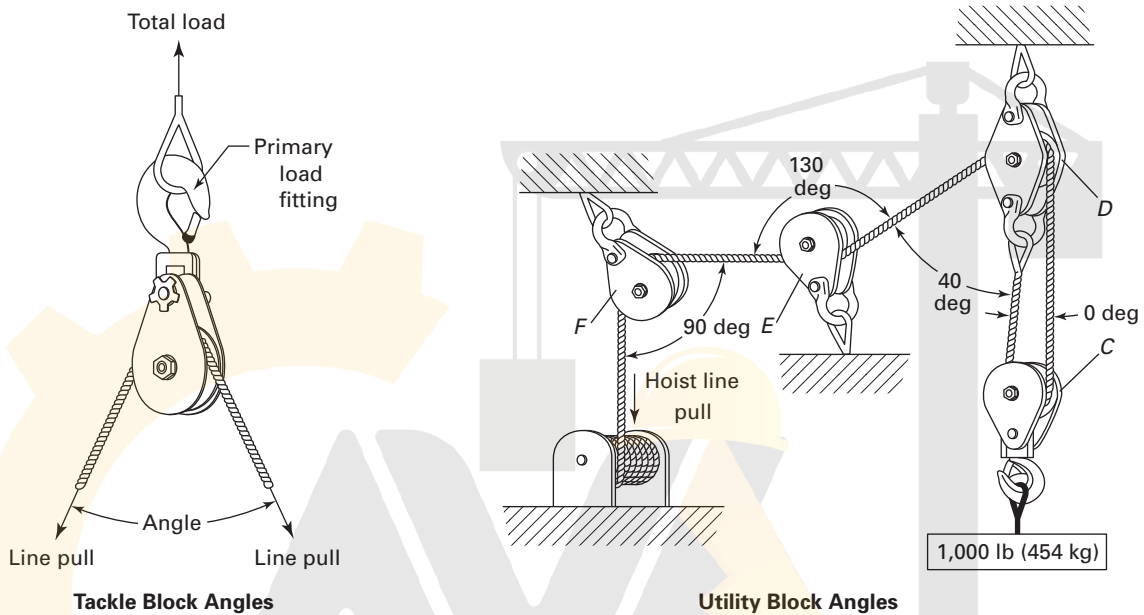

Fig. 26-5.3-1 Block Load Factor Multipliers

(15)



Multipliers

Angle, deg	Factor	Angle, deg	Factor
0	2.00	100	1.29
10	1.99	110	1.15
20	1.97	120	1.00
30	1.93	130	0.84
40	1.87	135	0.76
45	1.84	140	0.68
50	1.81	150	0.52
60	1.73	160	0.35
70	1.64	170	0.17
80	1.53	180	0.00
90	1.41

Block Load = Line Pull × Multiplier Factor

Example: Load = 1,000 lb (454 kg)

Line pull: 1,000 lb (454 kg) ÷ 2 = 500 lb (227 kg)

Load block C = 500 lb (227 kg) × 2 = 1,000 lb (454 kg)

(line pull × factor for 0-deg angle)

Load block D = 500 lb (227 kg) × 1.87 + 500 lb (227 kg) = 1,435 lb (651 kg)

(line pull × factor for 40-deg angle + dead-end load)

Load block E = 500 lb (227 kg) × 0.84 = 420 lb (190 kg)

(line pull × factor for 130-deg angle)

Load block F = 500 lb (227 kg) × 1.41 = 705 lb (320 kg)

(line pull × factor for 90-deg angle)



26-5.8: INSPECTION, REPAIR, AND REMOVAL

26-5.8.1 General

All inspections shall be performed by a designated person. Any deficiencies identified shall be examined and a determination made by a qualified person as to whether they constitute a hazard.

26-5.8.2 Initial Inspection

Prior to use, all new, altered, modified, or repaired rigging blocks shall be inspected to verify compliance with the applicable provisions of this Chapter. Written records are not required.

26-5.8.3 Frequent Inspection

(a) A visual inspection shall be performed each shift before the rigging block is used. Rigging hardware in semi-permanent and inaccessible locations where frequent inspections are not feasible shall have periodic inspections performed.

(b) Conditions such as those listed in para. 26-5.8.5, or any other condition that may result in a hazard, shall cause the rigging block to be removed from service. Rigging blocks shall not be returned to service until approved by a qualified person.

(c) Written records are not required.

26-5.8.4 Periodic Inspection

(a) A complete inspection of the rigging block shall be performed. The rigging block shall be examined for conditions such as those listed in para. 26-5.8.5 and a determination made as to whether they constitute a hazard.

(b) *Periodic Inspection Frequency*

(1) Periodic inspection intervals shall not exceed 1 yr. The frequency of periodic inspections should be based on

- (-a) frequency of use
- (-b) severity of service conditions
- (-c) nature of lifting or load handling activities
- (-d) experience gained on the service life of rigging blocks used in similar circumstances

(2) Guidelines for the time intervals are

- (-a) normal service — yearly
- (-b) severe service — monthly to quarterly
- (-c) special service — as recommended by a qualified person

(c) Written records are not required.

26-5.8.5 Removal Criteria

Rigging blocks shall be removed from service if conditions such as the following are present and shall only be returned to service when approved by a qualified person:

(a) missing or illegible identification

(b) misalignment or wobble in sheaves
(c) excessive sheave groove corrugation or wear
(d) loose or missing nuts, bolts, cotter pins, snap rings, or other fasteners and retaining devices

(e) indications of heat damage, including weld spatter or arc strikes

(f) excessive pitting or corrosion

(g) bent, cracked, twisted, distorted, stretched, elongated, or broken load-bearing components

(h) excessive wear, nicks, or gouges

(i) a 10% reduction of the original or catalog dimension at any point

(j) excessive damage to load-bearing threads

(k) evidence of unauthorized welding or modifications

(l) for hooks, the removal criteria specified in B30.10

(m) for shackles, the removal criteria specified in B30.26

(n) other conditions, including visible damage that cause doubt as to the continued use of the rigging block

26-5.8.6 Repairs and Modifications

(a) Repairs, alterations, or modifications shall be as specified by the rigging block manufacturer or a qualified person.

(b) Replacement parts, such as pins, hooks and sheaves, shall meet or exceed the original equipment manufacturer's specifications.

SECTION 26-5.9: OPERATING PRACTICES

26-5.9.1 Rigging Block Selection

(15)

(a) Rigging blocks having suitable characteristics for the application, included angle, and environment shall be selected in accordance with the recommendations of the rigging block manufacturer or a qualified person.

NOTE: The included angle formed between the load lines affects the load on the block. As the included angle decreases, the load increases in the rigging block (see Fig. 26-5.3-1).

(b) The rated load of the rigging block shall not be exceeded.

(c) Rigging blocks that appear to be damaged shall not be used until inspected and accepted as usable under para. 26-5.8.4.

(d) The minimum D/d ratio between the sheave pitch diameter and wire rope diameter is 6.

26-5.9.2 Cautions to Personnel

(a) All portions of the human body shall be kept from between the rigging block, its running lines, the load, and any other rigging during lifting or load handling activities.

(b) Personnel should stand clear of the suspended load.



Personnel should stand clear of rigging when it is in use.

(c) Personnel shall not ride rigging blocks.

26-5.9.3 Storage and Work Environments

(a) Rigging blocks should be stored in an area where they will not be subjected to damage, corrosive action, or extreme temperatures.

(b) If extreme temperatures or chemically active environments are involved, the guidance provided in para. 26-5.6.1 or 26-5.6.2 shall be followed.

(15) 26-5.9.4 Rigging Practices

(a) The rigging block components shall be fully engaged, with all fasteners and retaining devices in place

and in good working order before use. Alterations or modifications shall comply with para. 26-5.8.6.

(b) Contact with sharp edges that could damage the rigging block should be avoided.

(c) Shock loading should be avoided.

(d) The load applied to the rigging block should be in-line with the sheave and load fitting(s) to prevent side loading of the block.

(e) Ensure the rope is in the sheave groove when the rigging block begins to take load.

(f) The line load multiplied by the block load factor shall not exceed the rated load of the rigging block (see Fig. 26-5.3-1).

(g) Rigging blocks should not be dragged on an abrasive surface.

(h) Load line fittings shall not contact the rigging block sheave(s).

آریا ایمن آوات



Chapter 26-6

Detachable Load-Indicating Devices – Selection, Use, and Maintenance

SECTION 26-6.0: SCOPE

This Chapter applies to detachable load-indicating devices (LIDs) used in tension.

SECTION 26-6.1: TYPES AND MATERIALS

26-6.1.1 Types

(a) Types covered are crane scales, dynamometers, and shackles with load-indicating pins (see Figs. 26-6.1.1-1 through 26-6.1.1-3).

(b) LIDs shall be used only in accordance with the recommendations of the LID manufacturer or a qualified person.

NOTE: Load-indicating pins integral to a hoisting system and load-indicating devices that operate on a running wire rope are not covered by the scope of this Volume.

(15) 26-6.1.2 Materials

The LID shall have sufficient ductility to permanently deform before losing the ability to support the load at the temperatures the manufacturer has specified for use.

SECTION 26-6.2: DESIGN FACTOR

The design factor shall be a minimum of 4.

SECTION 26-6.3: RATED LOADS

Rated load shall be in accordance with the recommendation of the LID manufacturer. The terms *rated capacity* and *working load limit* are commonly used to describe rated load.

SECTION 26-6.4: PROOF TEST

(15) 26-6.4.1 Proof Test Requirements

(a) LIDs are not required to be proof tested unless specified by the purchaser.

(b) Proof tested LID(s) shall be inspected after the test for the conditions stated in para. 26-6.8.6.

26-6.4.2 Proof Load Requirements

The proof load for a LID shall be a minimum of 2 times the rated load.

SECTION 26-6.5: IDENTIFICATION

26-6.5.1 LID Identification

(15)

Each LID shall be durably marked by the manufacturer to show

- (a) name or trademark of manufacturer
- (b) rated load
- (c) serial number
- (d) model number
- (e) controls

26-6.5.2 Maintenance of Identification

LID identification should be maintained by the user so as to be legible throughout the life of the LID.

SECTION 26-6.6: EFFECTS OF ENVIRONMENT

26-6.6.1 Temperature

When LIDs are to be used at temperatures above 104°F (40°C) or below 14°F (–10°C), the LID manufacturer or a qualified person shall be consulted.

26-6.6.2 Chemically Active Environments

(15)

The strength and accuracy of LIDs can be affected by chemically active environments, such as caustic or acidic substances or fumes. The LID manufacturer or a qualified person shall be consulted before LIDs are used in chemically active environments.

26-6.6.3 Electronic Interference

Electromagnetic interference (EMI) and radio frequency interference (RFI) may affect the accuracy of LIDs. The LID manufacturer or a qualified person shall be consulted before LIDs are used in these environments.

SECTION 26-6.7: TRAINING

LID users shall be trained in the selection, use, inspection, cautions to personnel, effects of environment, and rigging practices as covered by this Chapter. The user shall consult the OEM manual for specific instructions relating to the use of the LID.

Fig. 26-6.1.1-1 Crane Scale – Dynamometer

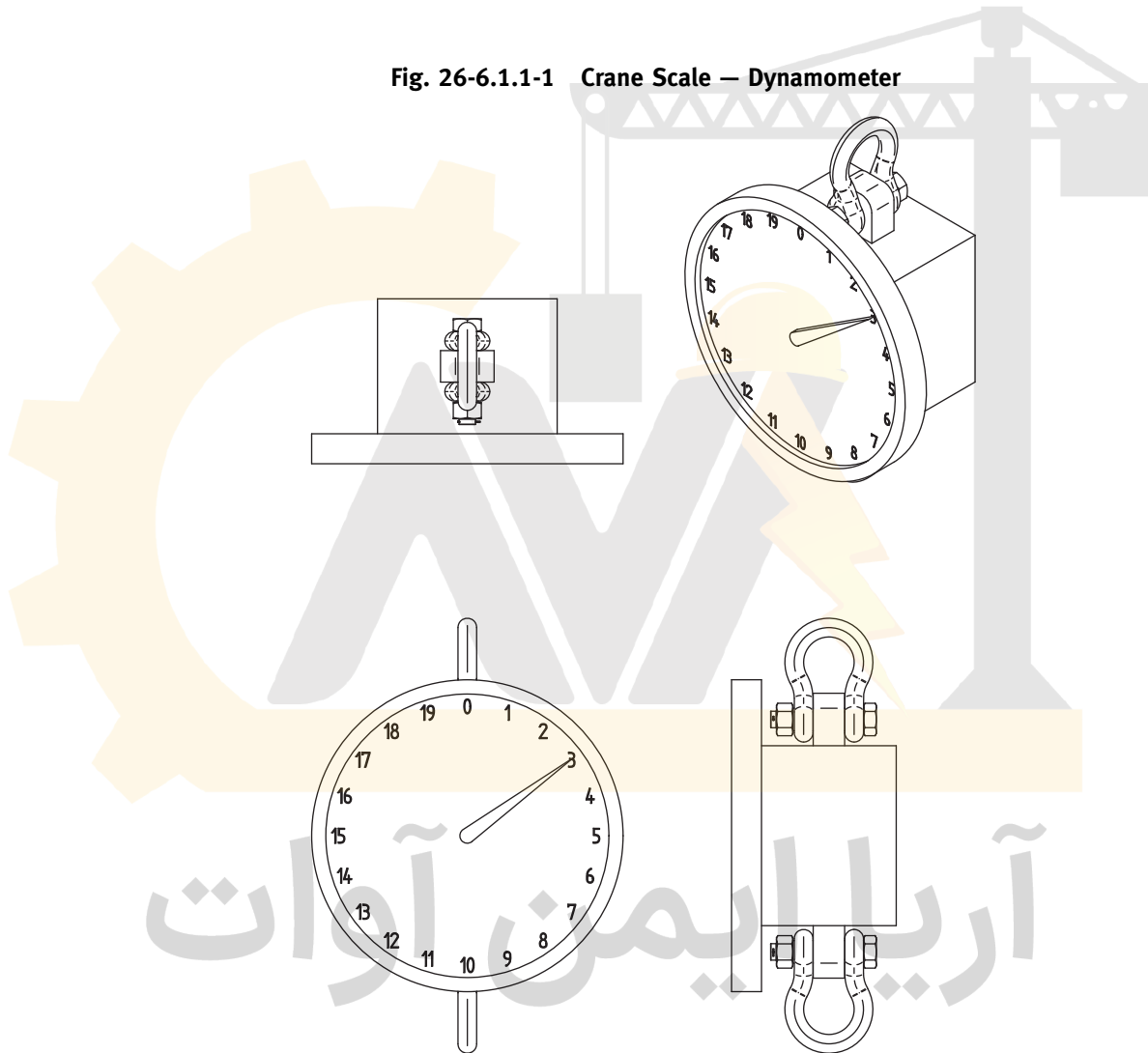

Fig. 26-6.1.1-2 Link Style Load-Indicating Device

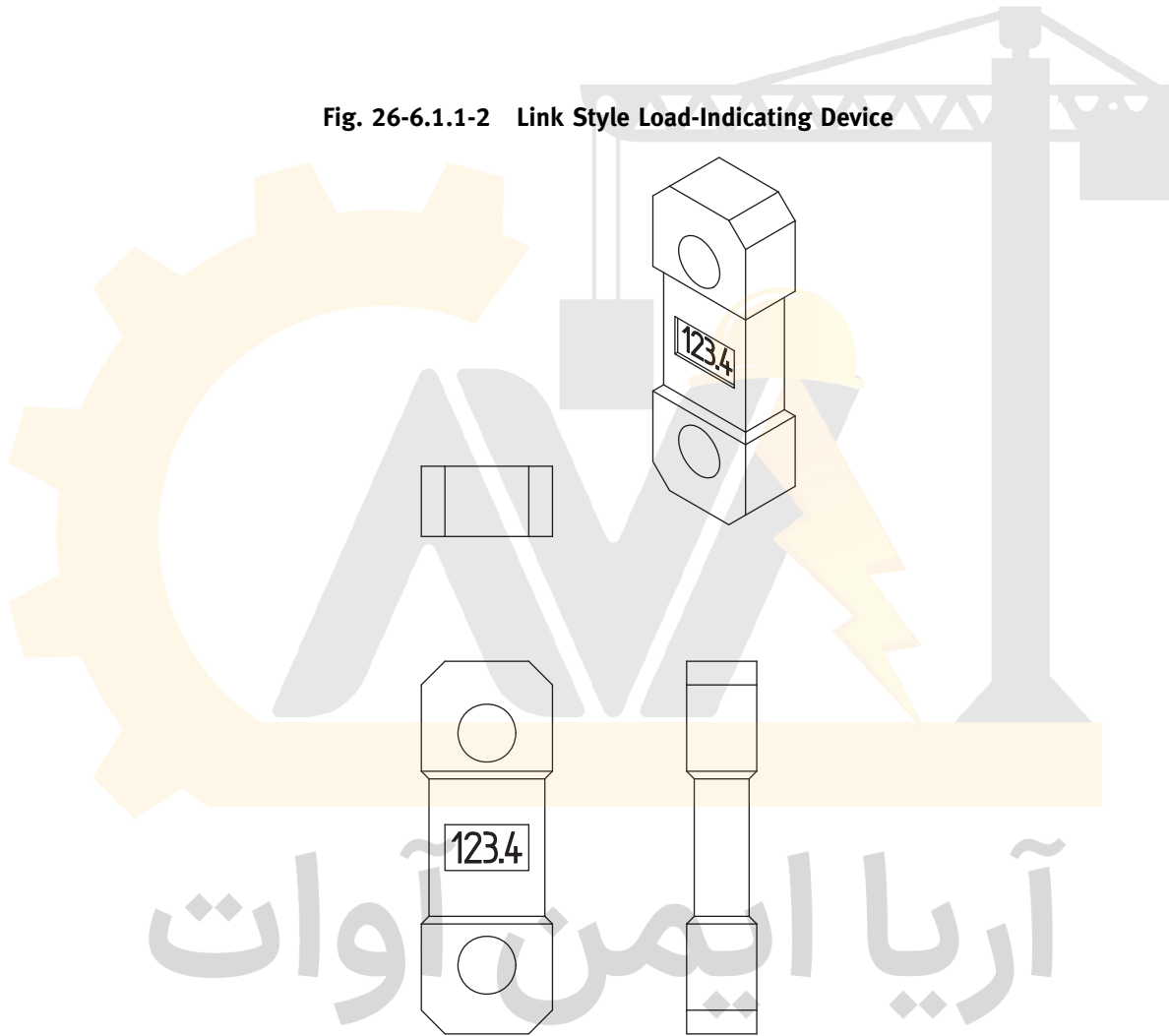
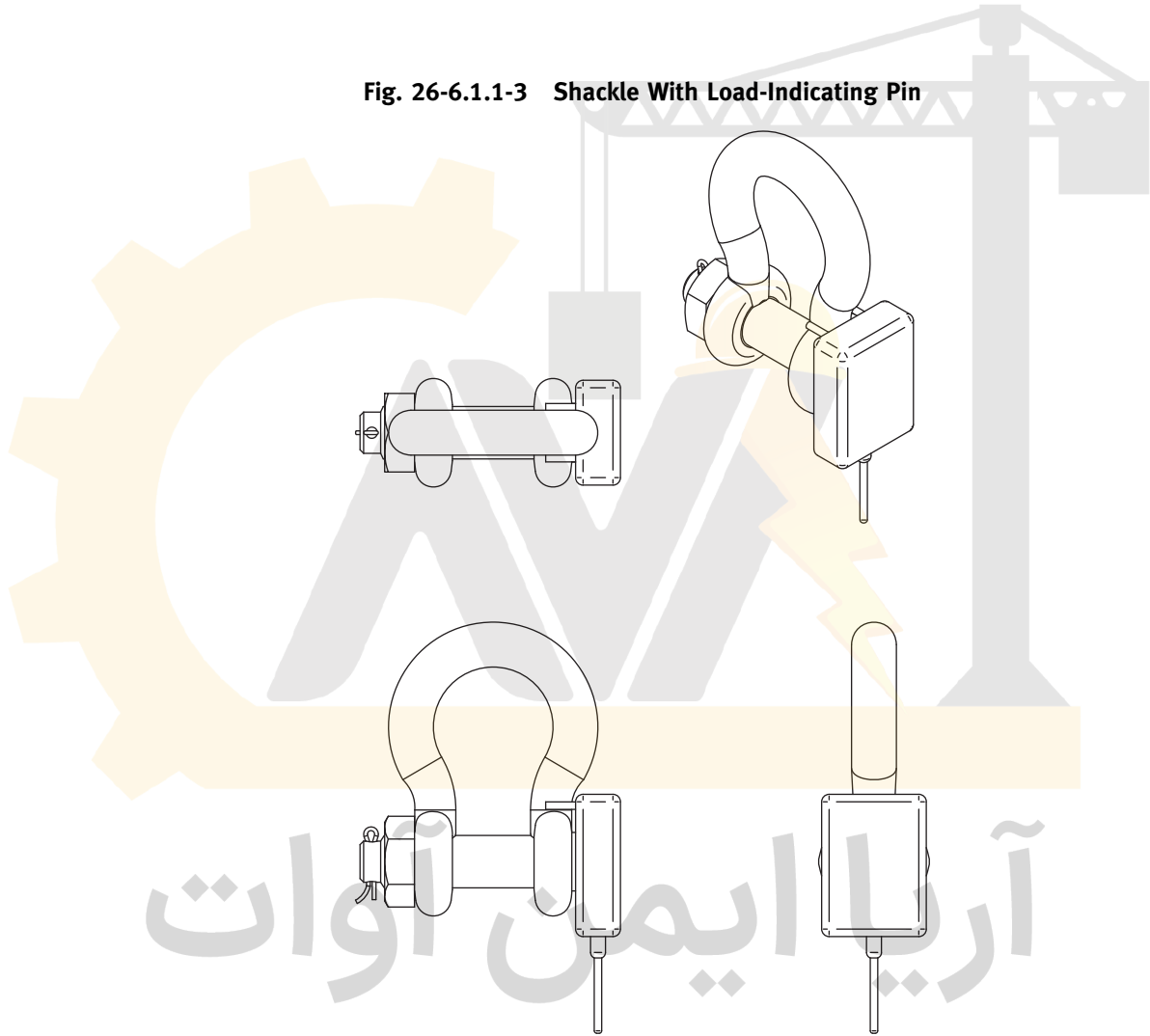

Fig. 26-6.1.1-3 Shackle With Load-Indicating Pin





6.8: CALIBRATION, INSPECTION, REPAIR, AND REMOVAL

6.8.1 General

All inspections shall be performed by a designated person. Any deficiencies identified shall be examined and a determination made by a qualified person as to whether they constitute a hazard.

26-6.8.2 Calibration

(a) Prior to use, all new, altered, modified, or repaired LIDs shall be calibrated to within $\pm 2\%$ of the LID maximum rated load, by the manufacturer or a qualified person. A written record of the most recent calibration shall be maintained.

(b) Periodic calibration shall be performed at intervals specified by the manufacturer or a qualified person in accordance with para. 26-6.8.2(a). A written record of the most recent calibration shall be maintained.

26-6.8.3 Initial Inspection

Prior to use, all new, altered, modified, or repaired LIDs shall be inspected to verify compliance with the applicable provisions of this Chapter. A written record of the new LID shall be established in order to record future repairs, modifications, or a report of condition during periodic inspections.

26-6.8.4 Frequent Inspection

(a) A visual inspection shall be performed each shift before the LID is used. LIDs in semi-permanent and inaccessible locations, where frequent inspections are not feasible, shall have periodic inspections performed.

(b) Conditions such as those listed in para. 26-6.8.6 or any other condition that may result in a hazard shall cause the LIDs to be removed from service. LIDs shall not be returned to service until approved by a qualified person.

(c) Written records are not required for frequent inspections.

26-6.8.5 Periodic Inspection

(a) A complete inspection of the LID shall be performed. The LID shall be examined for conditions such as those listed in para. 26-6.8.6 and a determination made as to whether they constitute a hazard.

(b) Periodic Inspection Frequency

(1) Periodic inspection intervals shall not exceed 1 yr. The frequency of periodic inspections should be based on

- (-a) frequency of use
- (-b) severity of service conditions
- (-c) nature of lifting or load handling activities
- (-d) experience gained on the service life of LIDs used in similar circumstances

(2) Guidelines for the time intervals are

- (-a) normal service — yearly

(-b) severe service — monthly to quarterly

(-c) special service — as recommended by a qualified person

(c) A written record of the most recent periodic inspection shall be maintained and shall include the condition of the LID.

26-6.8.6 Removal Criteria

A LID and its remote readout, if applicable, shall be removed from service if conditions such as the following are present and shall only be returned to service when approved by a qualified person:

- (a) missing or illegible identification
- (b) indications of heat damage, including weld spatter or arc strikes
- (c) excessive pitting or corrosion
- (d) bent, twisted, distorted, stretched, elongated, cracked, or broken load-bearing components
- (e) excessive nicks or gouges
- (f) any reduction of the original or catalog dimension at any point inside of the load-sensing zone
- (g) a 5% reduction of the original or catalog dimension at any point outside of the load-sensing zone
- (h) illegible display or readout
- (i) damaged or deformed component hardware
- (j) evidence of unauthorized welding or modification
- (k) other conditions, including visible damage, that cause doubt as to the continued use of the LID

26-6.8.7 Repairs and Modifications

(a) Repairs, alterations, or modifications shall be as specified by the LID manufacturer or a qualified person.

(b) Replacement parts shall meet or exceed the LID manufacturer's specifications.

SECTION 26-6.9: OPERATING PRACTICES

26-6.9.1 LID Selection

(15)

(a) LIDs having suitable characteristics for the type of service, load rating, and environment shall be selected in accordance with the recommendations of the LID manufacturer or a qualified person.

NOTE: The angle of loading affects the stress in the LID. As the horizontal angle decreases, the stress increases in the LID (see Section 26-6.3).

(b) The rated load of the LID shall not be exceeded.

(c) LIDs that appear to be damaged shall be removed from service, inspected, and only returned to service after being approved by a qualified person, in accordance with Section 26-6.8.

26-6.9.2 Cautions to Personnel

(15)

(a) All portions of the human body shall be kept from between the load and any other rigging during lifting or load handling activities.



Personnel should stand clear of the suspended

(c) Personnel should stand clear of rigging when it is under tension.

(d) Personnel shall not ride the LID.

26-6.9.3 Storage and Work Environments

(a) LIDs should be stored in an area where they will not be subjected to damage, moisture, corrosive action, or extreme temperatures.

(b) If extreme temperatures or chemically active or electronically disruptive environments are involved, the guidance provided in para. 26-6.6.1, 26-6.6.2, or 26-6.6.3 shall be followed.

26-6.9.4 Rigging Practices

(15)

(a) The rigging components connected to the LID shall be properly attached and secured.

(b) Alterations or modifications shall comply with para. 26-6.8.7(a).

(c) Contact with sharp edges, which could damage the LID, should be avoided.

(d) Shock loading should be avoided.

(e) The load applied to the LID should be on its centerline and in tension.

(f) Multiple slings should not be applied to the pin of a shackle with a load-indicating pin.

(g) The LID shall not be side loaded.

(h) LIDs should not be dragged on an abrasive surface.

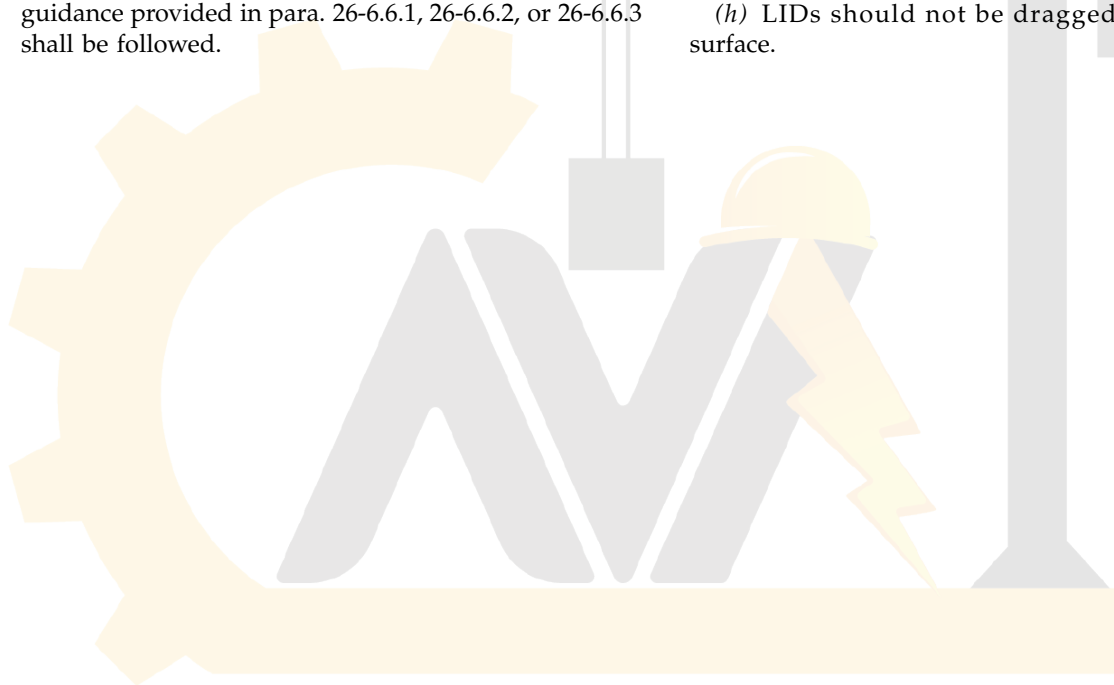

آريا ايمن آوات

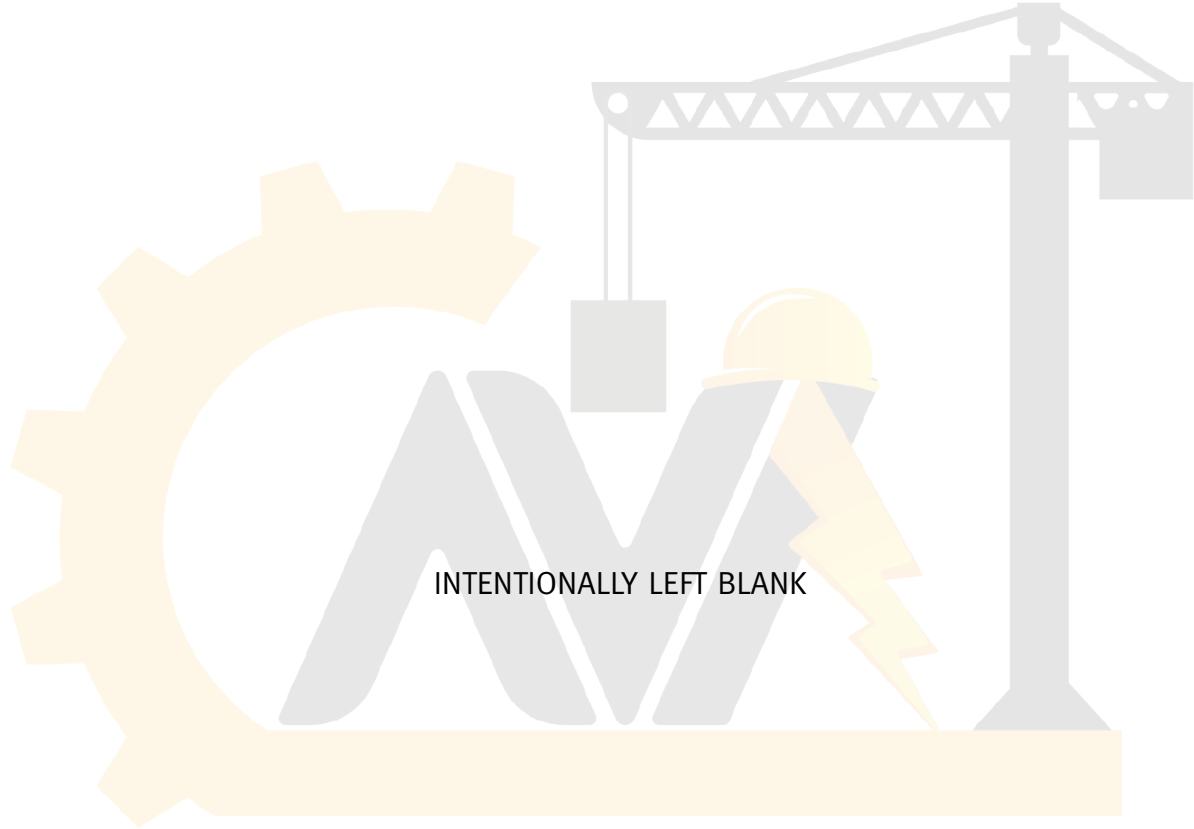

آریا ایمن آوات



ASME B30.26 INTERPRETATIONS

Replies to Technical Inquiries June 2010 Through June 2014

FOREWORD

This publication includes all of the written replies issued between the indicated dates by the Secretary, speaking for the ASME B30 Standards Committee, Safety Standard for Cableways, Cranes, Derricks, Hoists, Hooks, Jacks, and Slings, to inquiries concerning interpretations of technical aspects of ASME B30.26, Rigging Hardware.

These replies are taken verbatim from the original letters except for a few minor typographical and editorial corrections made for the purpose of improved clarity. In some few instances, a review of the interpretation revealed a need for corrections of a technical nature; in these cases, a corrected interpretation follows immediately after the original reply.

These interpretations were prepared in accordance with the accredited ASME procedures. ASME procedures provide for reconsideration of these interpretations when or if additional information is available that the inquirer believes might affect the interpretation. Further, persons aggrieved by an interpretation may appeal to the cognizant ASME Committee or Subcommittee. ASME does not "approve," "certify," "rate," or "endorse" any item, construction, proprietary device, or activity.

آریا ایمن آوات

**Interpretation: 26-5**

Subject: ASME B30.26-2004, Paragraphs 26-2.9.4.4 and 26-2.8.4(i)

Date Issued: June 23, 2010

Question (1): I am requesting a definition or quantification of "free to rotate and pivot."

Reply (1): "Free to rotate" requires that the device is not fixed and is capable of relatively unrestricted motion to turn on its axes. If the user has concerns regarding the forces required to rotate the device on its axes, they should contact the device manufacturer.

Question (2): What is the appropriate or recommended thread class for the internal thread of a tapped hole used for swivel hoist rings?

Reply (2): Paragraph 26-2.9.4.4 does not provide design information for thread class. For specific material systems or applications, the manufacturer or a qualified person should be contacted.

Interpretation: 26-6

Subject: ASME B30.26-2010, Section 26-1.5, Identification

Date Issued: October 5, 2011

Question (1): Per para. 26-1.5.1, if a shackle body does not have all the identification markings, such as manufacturer's name, trademark, rated load, and size, does the shackle conform to standard as required?

Reply (1): No.

Question (2): Per para. 26-1.5.1, if shackle body identification markings such as manufacturer's name, trademark, rated load, and size are not forged, cast, or die stamped, does the shackle conform to standard as required?

Reply (2): No.

Question (3): Per para. 26-1.5.2, if a shackle pin does not have all the identification markings, such as manufacturer's name, trademark, rated load, material type, or grade, does the shackle pin conform to standard as required?

Reply (3): No.

Interpretation: 26-7

Subject: ASME B30.26-2010, Paragraph 26-6.5.1

Date Issued: June 3, 2014

Question (1): Does the identification referred to in para. 26-6.5.1 apply to each individual component?

Reply (1): No.

Question (2): Does the identification referred to in para. 26-6.5.1 apply to the device?

Reply (2): Yes.



30.26-2015

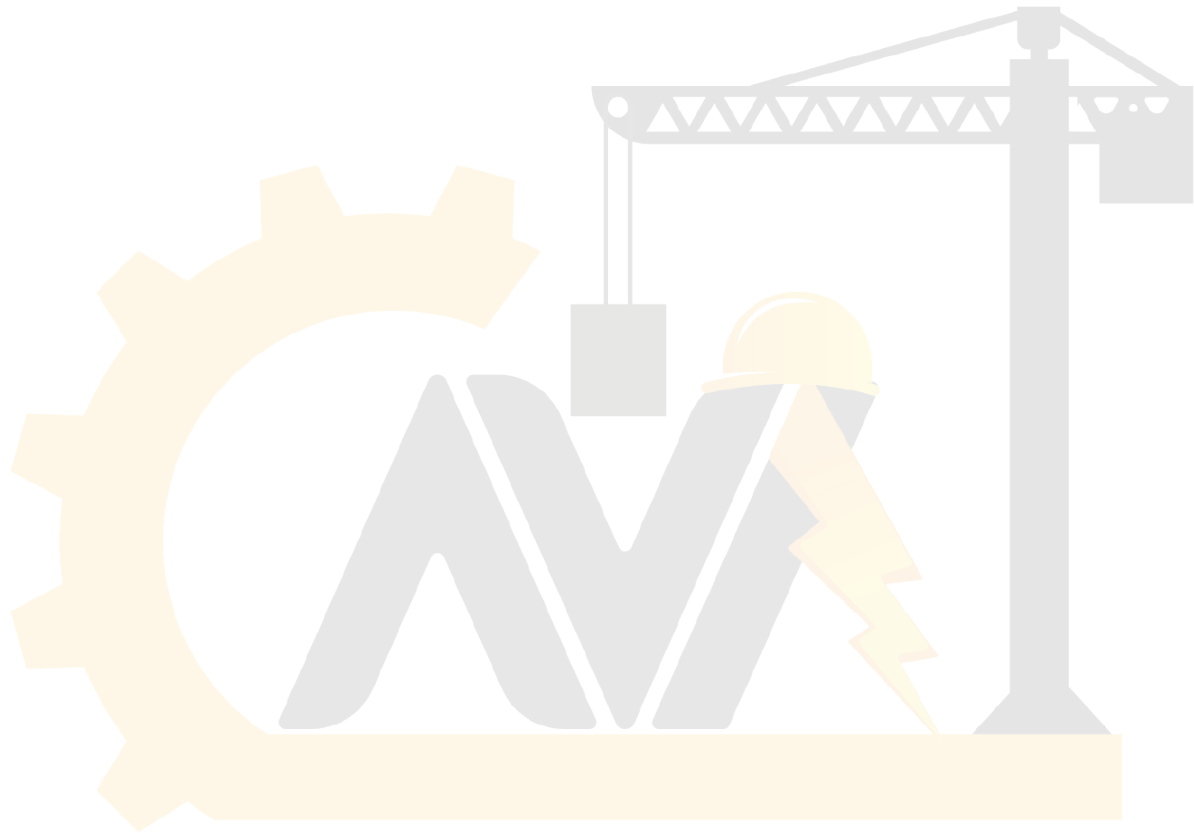

آریا ایمن آوات

ISBN 978-0-7918-7023-5

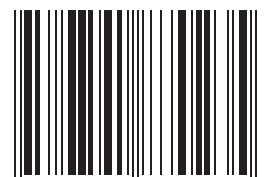

9 780791 870235



J17015