



**ASME B30.9-2018**  
(Revision of ASME B30.9-2014)

# Slings

**Safety Standard for Cableways,  
Cranes, Derricks, Hoists, Hooks, Jacks,  
and Slings**

**AN AMERICAN NATIONAL STANDARD**



**The American Society of  
Mechanical Engineers**



**ASME B30.9-2018**  
(Revision of ASME B30.9-2014)

# Slings

---

**Safety Standard for Cableways,  
Cranes, Derricks, Hoists, Hooks, Jacks,  
and Slings**

AN AMERICAN NATIONAL STANDARD



**The American Society of  
Mechanical Engineers**

Two Park Avenue • New York, NY • 10016 USA



Date of Issuance: May 15, 2018

The next edition of this Standard is scheduled for publication in 2021. This Standard will become effective 1 year after the Date of Issuance.

ASME issues written replies to inquiries concerning interpretations of technical aspects of this Standard. Interpretations are published on the ASME website under the Committee Pages at <http://cstools.asme.org/> as they are issued.

Errata to codes and standards may be posted on the ASME website under the Committee Pages to provide corrections to incorrectly published items, or to correct typographical or grammatical errors in codes and standards. Such errata shall be used on the date posted.

The Committee Pages can be found at <http://cstools.asme.org/>. There is an option available to automatically receive an e-mail notification when errata are posted to a particular code or standard. This option can be found on the appropriate Committee Page after selecting "Errata" in the "Publication Information" section.

ASME is the registered trademark of The American Society of Mechanical Engineers.

This code or standard was developed under procedures accredited as meeting the criteria for American National Standards. The Standards Committee that approved the code or standard was balanced to assure that individuals from competent and concerned interests have had an opportunity to participate. The proposed code or standard was made available for public review and comment that provides an opportunity for additional public input from industry, academia, regulatory agencies, and the public-at-large.

ASME does not "approve," "rate," or "endorse" any item, construction, proprietary device, or activity.

ASME does not take any position with respect to the validity of any patent rights asserted in connection with any items mentioned in this document, and does not undertake to insure anyone utilizing a standard against liability for infringement of any applicable letters patent, nor assume any such liability. Users of a code or standard are expressly advised that determination of the validity of any such patent rights, and the risk of infringement of such rights, is entirely their own responsibility.

Participation by federal agency representative(s) or person(s) affiliated with industry is not to be interpreted as government or industry endorsement of this code or standard.

ASME accepts responsibility for only those interpretations of this document issued in accordance with the established ASME procedures and policies, which precludes the issuance of interpretations by individuals.

No part of this document may be reproduced in any form,  
in an electronic retrieval system or otherwise,  
without the prior written permission of the publisher.

The American Society of Mechanical Engineers  
Two Park Avenue, New York, NY 10016-5990

Copyright © 2018 by  
THE AMERICAN SOCIETY OF MECHANICAL ENGINEERS  
All rights reserved  
Printed in U.S.A.

# CONTENTS

Foreword .....	vii
Committee Roster .....	viii
B30 Standard Introduction .....	xi
Summary of Changes .....	xiv
<b>Chapter 9-0 Scope, Definitions, Personnel Competence, Rigger Responsibilities, Translations, and References .....</b>	<b>1</b>
Section 9-0.1 Scope of ASME B30.9 .....	1
Section 9-0.2 Definitions .....	1
Section 9-0.3 Personnel Competence .....	3
Section 9-0.4 Rigger Responsibilities .....	3
Section 9-0.5 Original and Translated Technical and Safety-Related Information .....	3
Section 9-0.6 References .....	3
<b>Chapter 9-1 Alloy Steel Chain Slings: Selection, Use, and Maintenance .....</b>	<b>5</b>
Section 9-1.0 Scope .....	5
Section 9-1.1 Training .....	5
Section 9-1.2 Components .....	5
Section 9-1.3 Fabrication and Configurations .....	5
Section 9-1.4 Design Factor .....	5
Section 9-1.5 Rated Load .....	5
Section 9-1.6 Proof Test Requirements .....	7
Section 9-1.7 Sling Identification .....	7
Section 9-1.8 Effects of Environment .....	7
Section 9-1.9 Inspection, Removal, and Repair .....	7
Section 9-1.10 Operating Practices .....	9
<b>Chapter 9-2 Wire Rope Slings: Selection, Use, and Maintenance .....</b>	<b>11</b>
Section 9-2.0 Scope .....	11
Section 9-2.1 Training .....	11
Section 9-2.2 Components .....	11
Section 9-2.3 Fabrication and Configurations .....	11
Section 9-2.4 Design Factor .....	12
Section 9-2.5 Rated Load .....	12
Section 9-2.6 Proof Test Requirements .....	12
Section 9-2.7 Sling Identification .....	13
Section 9-2.8 Effects of Environment .....	13
Section 9-2.9 Inspection, Removal, and Repair .....	14
Section 9-2.10 Operating Practices .....	15
<b>Chapter 9-3 Metal Mesh Slings: Selection, Use, and Maintenance .....</b>	<b>18</b>
Section 9-3.0 Scope .....	18

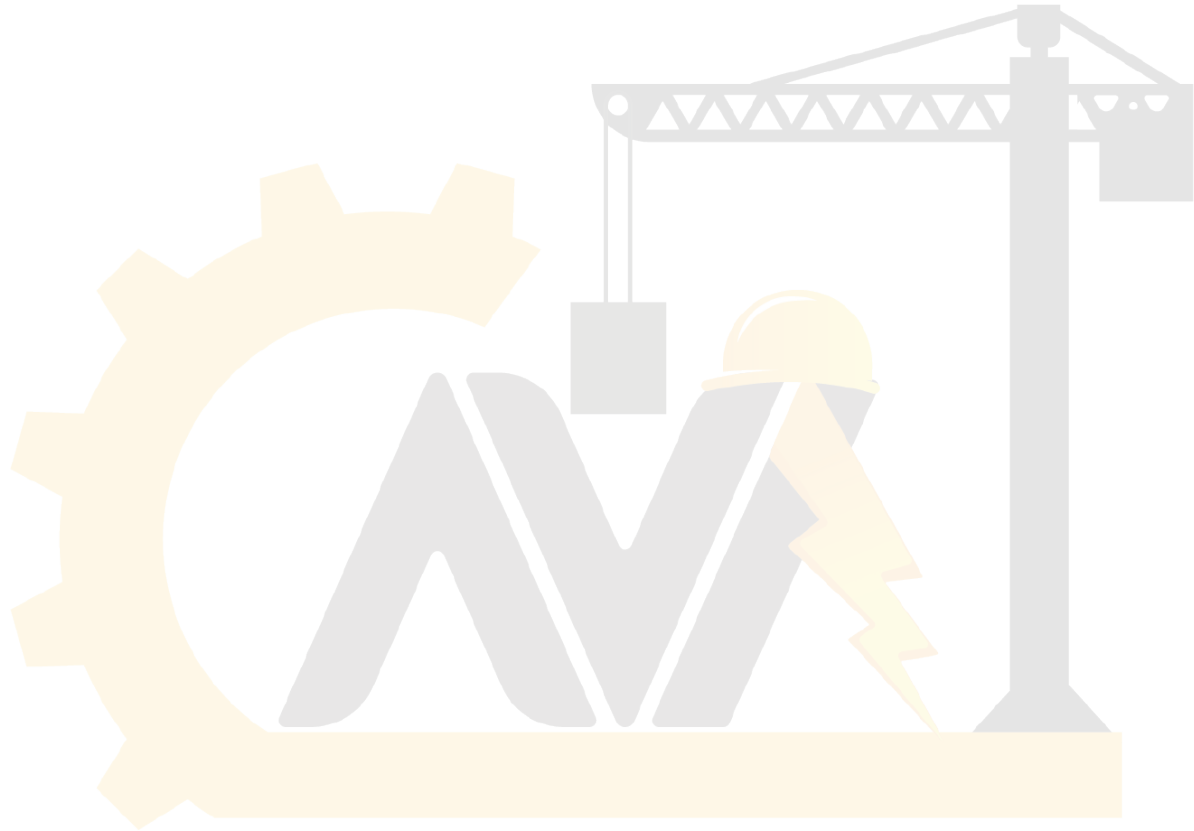


Section 9-3.3	Training . . . . .	18
Section 9-3.4	Components . . . . .	18
Section 9-3.5	Fabrication and Configurations . . . . .	18
Section 9-3.6	Design Factor . . . . .	18
Section 9-3.7	Rated Load . . . . .	18
Section 9-3.8	Proof Test Requirements . . . . .	18
Section 9-3.9	Sling Identification . . . . .	18
Section 9-3.10	Effects of Environment . . . . .	19
Section 9-3.10	Inspection, Removal, and Repair . . . . .	20
Section 9-3.10	Operating Practices . . . . .	21
<b>Chapter 9-4</b>	<b>Synthetic Rope Slings: Selection, Use, and Maintenance</b> . . . . .	<b>23</b>
Section 9-4.0	Scope . . . . .	23
Section 9-4.1	Training . . . . .	23
Section 9-4.2	Components . . . . .	23
Section 9-4.3	Fabrication and Configurations . . . . .	23
Section 9-4.4	Design Factor . . . . .	24
Section 9-4.5	Rated Load . . . . .	24
Section 9-4.6	Proof Test Requirements . . . . .	24
Section 9-4.7	Sling Identification . . . . .	26
Section 9-4.8	Effects of Environment . . . . .	26
Section 9-4.9	Inspection, Removal, and Repair . . . . .	26
Section 9-4.10	Operating Practices . . . . .	27
<b>Chapter 9-5</b>	<b>Synthetic Webbing Slings: Selection, Use, and Maintenance</b> . . . . .	<b>30</b>
Section 9-5.0	Scope . . . . .	30
Section 9-5.1	Training . . . . .	30
Section 9-5.2	Components . . . . .	30
Section 9-5.3	Fabrication and Configurations . . . . .	30
Section 9-5.4	Design Factor . . . . .	30
Section 9-5.5	Rated Load . . . . .	30
Section 9-5.6	Proof Test Requirements . . . . .	32
Section 9-5.7	Sling Identification . . . . .	32
Section 9-5.8	Effects of Environment . . . . .	32
Section 9-5.9	Inspection, Removal, and Repair . . . . .	32
Section 9-5.10	Operating Practices . . . . .	33
<b>Chapter 9-6</b>	<b>Polyester Roundslings: Selection, Use, and Maintenance</b> . . . . .	<b>35</b>
Section 9-6.0	Scope . . . . .	35
Section 9-6.1	Training . . . . .	35
Section 9-6.2	Components . . . . .	35
Section 9-6.3	Fabrication and Configurations . . . . .	35
Section 9-6.4	Design Factor . . . . .	36
Section 9-6.5	Rated Load . . . . .	36
Section 9-6.6	Proof Test Requirements . . . . .	36
Section 9-6.7	Sling Identification . . . . .	36
Section 9-6.8	Effects of Environment . . . . .	37
Section 9-6.9	Inspection, Removal, and Repair . . . . .	37



-6.10	Operating Practices .....	38
9-7	<b>High Performance Roundslings: Selection, Use, and Maintenance</b> .....	40
Section 9-7.0	Scope .....	40
Section 9-7.1	Training .....	40
Section 9-7.2	Components .....	40
Section 9-7.3	Fabrication and Configurations .....	40
Section 9-7.4	Design Factor .....	41
Section 9-7.5	Rated Load .....	41
Section 9-7.6	Proof Test Requirements .....	41
Section 9-7.7	Sling Identification .....	41
Section 9-7.8	Effects of Environment .....	42
Section 9-7.9	Inspection, Removal, and Repair .....	42
Section 9-7.10	Operating Practices .....	43
<b>Figures</b>		
9-1.0-1	Alloy Steel Chain Slings: Configurations, Components, and Hitches .....	6
9-1.5-1	Angle of Loading .....	7
9-2.0-1	Wire Rope Sling .....	11
9-2.0-2	Wire Rope .....	12
9-2.3.2-1	Minimum Sling Length .....	13
9-2.3.2-2	Minimum Braided Sling Length .....	13
9-2.5-1	Angle of Loading .....	13
9-2.9.5-1	Cable-Laid Wire Rope Sling .....	15
9-2.10.1-1	<i>D/d</i> Ratio: Wire Rope Slings .....	16
9-3.0-1	Metal Mesh Sling .....	19
9-3.5-1	Angle of Loading .....	20
9-3.10.1-1	Angle of Choke: Metal Mesh Slings .....	21
9-4.0-1	Synthetic Fiber Rope Slings .....	24
9-4.5-1	Hitch Types for Synthetic Rope Slings .....	25
9-4.5-2	Angle of Loading .....	26
9-4.10.1-1	<i>D/d</i> Ratio: Synthetic Rope Slings .....	28
9-5.0-1	Synthetic Webbing Slings .....	31
9-5.0-2	Synthetic Webbing Sling Nomenclature .....	31
9-5.5-1	Angle of Loading .....	31
9-6.0-1	Polyester Roundslings Types .....	35
9-6.5-1	Angle of Loading .....	36
9-7.0-1	High Performance Roundslings Types .....	40
9-7.5-1	Angle of Loading .....	41
<b>Tables</b>		
9-1.8.1-1	Effect of Elevated Temperature on Rated Load of Alloy Steel Chain .....	8
9-1.9.5-1	Minimum Allowable Thickness at Any Point on a Link .....	9
9-1.10.1-1	Basket Sling Hitch-Rated Capacity Affected by <i>D/d</i> .....	10
9-2.10.1-1	Angle of Choke: Wire Rope Slings .....	16
9-3.2.1-1	Fabric Construction: Metal Mesh Slings .....	19

Angle of Choke: Synthetic Rope Slings .....	28
Angle of Choke: Synthetic Webbing Slings .....	34
Angle of Choke: High Performance Roundslings .....	38
Angle of Choke: High Performance Roundslings .....	43



# آریا ایمن آوات



## FOREWORD

This American National Standard, Safety Standard for Cableways, Cranes, Derricks, Hoists, Hooks, Jacks, and Slings, has been developed under the procedures accredited by the American National Standards Institute (ANSI). This Standard had its beginning in December 1916 when an eight-page Code of Safety Standards for Cranes, prepared by the ASME Committee on the Protection of Industrial Workers, was presented to the annual meeting of the ASME.

Meetings and discussions regarding safety on cranes, derricks, and hoists were held from 1920 to 1925 involving the ASME Safety Code Correlating Committee, the Association of Iron and Steel Electrical Engineers, the American Museum of Safety, the American Engineering Standards Committee (AESC) [later changed to American Standards Association (ASA), then to the USA Standards Institute (USASI), and finally to ANSI], Department of Labor — State of New Jersey, Department of Labor and Industry — State of Pennsylvania, and the Locomotive Crane Manufacturers Association. On June 11, 1925, the AESC approved the ASME Safety Code Correlating Committee's recommendation and authorized the project with the U.S. Department of the Navy, Bureau of Yards and Docks, and ASME as sponsors.

In March 1926, invitations were issued to 50 organizations to appoint representatives to a Sectional Committee. The call for organization of this Sectional Committee was sent out October 2, 1926, and the committee organized on November 4, 1926, with 57 members representing 29 national organizations. Commencing June 1, 1927, and using the eight-page code published by ASME in 1916 as a basis, the Sectional Committee developed the "Safety Code for Cranes, Derricks, and Hoists." The early drafts of this safety code included requirements for jacks, but due to inputs and comments on those drafts, the Sectional Committee decided in 1938 to make the requirements for jacks a separate code. In January 1943, ASA B30.2-1943 was published addressing a multitude of equipment types and in August 1943, ASA B30.1-1943 was published addressing just jacks. Both documents were reaffirmed in 1952 and widely accepted as safety standards.

Due to changes in design, advancement in techniques, and general interest of labor and industry in safety, the Sectional Committee, under the joint sponsorship of ASME and the Bureau of Yards and Docks (now the Naval Facilities Engineering Command) was reorganized on January 31, 1962, with 39 members representing 27 national organizations. The new Committee changed the format of ASA B30.2-1943 so that the multitude of equipment types it addressed could be published in separate volumes that could completely cover the construction, installation, inspection, testing, maintenance, and operation of each type of equipment that was included in the scope of ASA B30.2. This format change resulted in the initial publication of B30.3, B30.5, B30.6, B30.11, and B30.16 being designated as revisions of B30.2 with the remainder of the B30 volumes being published as totally new volumes. ASA changed its name to USASI in 1966 and to ANSI in 1969, which resulted in B30 volumes from 1943 to 1968 being designated as ASA B30, USAS B30, or ANSI B30, depending on their date of publication.

In 1982, the Committee was reorganized as an Accredited Organization Committee, operating under procedures developed by ASME and accredited by ANSI. This Standard presents a coordinated set of rules that may serve as a guide to government and other regulatory bodies and municipal authorities responsible for the guarding and inspection of the equipment falling within its scope. The suggestions leading to accident prevention are given both as mandatory and advisory provisions; compliance with both types may be required by employers of their employees. In case of practical difficulties, new developments, or unnecessary hardship, the administrative or regulatory authority may grant variances from the literal requirements or permit the use of other devices or methods, but only when it is clearly evident that an equivalent degree of protection is thereby secured. To secure uniform application and interpretation of this Standard, administrative or regulatory authorities are urged to consult the B30 Committee, in accordance with the format described in Section IX of the Introduction, before rendering decisions on disputed points.

Safety codes and standards are intended to enhance public safety. Revisions result from committee consideration of factors such as technological advances, new data, and changing environmental and industry needs. Revisions do not imply that previous editions were inadequate.

The first edition of ASME B30.9 was issued in 1971; new editions were published in 1984, 1990, 1996, 2003, 2006, and 2010. The 2014 edition contained extensive revisions including the use of the term *load handling* to recognize that the load could be moving vertically or horizontally, and removal of the rated load tables, and addressed personnel competence and translations. This 2018 edition contains guidance concerning the inspection of stored slings, rigger responsibilities, and an entire chapter dedicated to high performance roundslings.

This edition of the B30.9 volume was approved by the B30 Committee and by ASME, and was approved by ANSI and designated as an American National Standard on March 23, 2018.





# ASME B30 COMMITTEE

## Safety Standard for Cableways, Cranes, Derricks, Hoists, Hooks, Jacks, and Slings

(The following is the roster of the Committee at the time of approval of this Standard.)

### STANDARDS COMMITTEE OFFICERS

**T. L. Blanton**, *Chair*  
**E. D. Fidler**, *Vice Chair*  
**K. M. Hyam**, *Secretary*

### STANDARDS COMMITTEE PERSONNEL

**N. E. Andrew**, LTS Crane Mechanical  
**T. L. Blanton**, NACB Group, Inc.  
**P. A. Boeckman**, The Crosby Group, Inc.  
**P. W. Boyd**, The Boeing Co.  
**B. D. Closson**, Craft Forensic Services  
**J. A. Danielson**, The Boeing Co.  
**D. R. Decker**, Becket, LLC  
**L. D. Demark, Sr.**, Equipment Training Solutions, LLC  
**D. W. Eckstine**, Eckstine & Associates  
**R. J. Edwards**, NationsBuilders Insurance Services, Inc.  
**A. J. Egging**, National Oilwell Varco  
**E. D. Fidler**, Grove U.S., LLC  
**J. A. Gilbert**, Associated Wire Rope Fabricators  
**J. L. Gordon**, Acco Material Handling Solutions, Inc.  
**N. C. Hargreaves**, Consultant  
**G. B. Hetherston**, Consultant  
**K. M. Hyam**, The American Society of Mechanical Engineers  
**M. M. Jaxheimer**, Navy Crane Center  
**P. R. Juhren**, Morrow Equipment Co., LLC  
**R. M. Kohner**, Landmark Engineering Services  
**A. J. Lusi, Jr.**, Lumark Consulting, LLP  
**E. K. Marburg**, Columbus McKinnon Corp.  
**L. D. Means**, Means Engineering & Consulting  
**M. W. Mills**, Liberty Mutual Insurance  
**D. L. Morgan**, Critical Lift Consultants, LLC  
**W. E. Osborn**, Ingersoll Rand  
**R. M. Parnell**, ITI-Field Service  
**J. T. Perkins**, First Solar Electric  
**B. A. Pickett**, Systems Engineering and Forensic Services  
**J. A. Pilgrim**, Manitowoc Cranes  
**S. K. Rammelsberg**, CB&I  
**J. E. Richardson**, U.S. Department of the Navy  
**D. W. Ritchie**, Dave Ritchie Consultant, LLC  
**J. W. Rowland III**, Consultant  
**J. C. Ryan**, Boh Bros. Construction Co.  
**D. W. Smith**, STI Group  
**W. J. Smith, Jr.**, NationsBuilders Insurance Services, Inc.  
**R. S. Stemp**, Lampson International, LLC  
**R. G. Strain**, Advanced Crane Technologies, LLC  
**J. Sturm**, Sturm Corp.  
**P. D. Sweeney**, Riverside Engineering, LLC  
**E. P. Vliet**, Consultant  
**J. D. Wiethorn**, Haag Engineering Co.  
**R. C. Wild**, CJ Drilling, Inc.  
**D. N. Wolff**, National Crane/Manitowoc Crane Group  
**S. D. Wood**, Terex Corp.  
**B. B. Bacon**, *Alternate*, Tennessee Valley Authority  
**R. J. Bolen**, *Alternate*, Consultant  
**G. J. Brent**, *Alternate*, NCCCO  
**J. R. Burkey**, *Alternate*, Columbus McKinnon Corp.  
**B. M. Casey**, *Alternate*, Electric Boat  
**W. C. Dickinson, Jr.**, *Alternate*, Crane Industry Services, LLC  
**J. Dudley**, *Alternate*, The Walsh Group  
**D. Duerr**, *Alternate*, 2DM Associates, Inc.  
**M. Eggenberger**, *Alternate*, Berry Contracting, Inc.  
**S. R. Fletcher**, *Alternate*, Cowles, Murphy, Glover & Associates  
**M. Gardiner**, *Alternate*, Haag Engineering Co.  
**S. R. Gridley**, *Alternate*, Navy Crane Center  
**D. A. Henninger**, *Alternate*, Bridon Bekaert, The Ropes Group  
**D. F. Jordan**, *Alternate*, American International Crane Bureau  
**K. Kennedy**, *Alternate*, Navy Crane Center  
**J. Lindsay**, *Alternate*, Link-Belt Construction Equipment  
**T. C. Mackey**, *Alternate*, WRPS Hanford, an AECOM Co.  
**J. P. Muhlbauer**, *Alternate*, All Ship & Cargo Surveys, Ltd.  
**D. A. Moore**, *Alternate*, Unified Engineering  
**L. S. Olver**, *Alternate*, Kolo Holdings, Inc.  
**J. M. Randall**, *Alternate*, CB&I  
**K. Rask**, *Alternate*, NationsBuilders Insurance Services, Inc.  
**C. L. Richardson**, *Alternate*, Lone Star Rigging, LP  
**A. R. Ruud**, *Alternate*, Atkinson Construction  
**J. R. Schober**, *Alternate*, American Bridge Co.  
**J. Schoppert**, *Alternate*, NBIS Claims & Risk Management  
**L. K. Shapiro**, *Alternate*, Howard I. Shapiro & Associates  
**K. Shinn**, *Alternate*, K. J. Shinn, Inc.  
**C. H. Smith**, *Alternate*, Morrow Equipment Co., LLC  
**S. Snider**, *Alternate*, Ingersoll Rand  
**R. Stanoch**, *Alternate*, IPS Cranes  
**C. Warren**, *Alternate*, Webber, LLC  
**A. T. West**, *Alternate*, Liberty Mutual Insurance  
**M. P. Zerba**, *Alternate*, Lampson International, LLC



## HONORARY MEMBERS

**J. W. Downs, Jr.**, Downs Crane and Hoist Co.  
**J. L. Franks**, Consultant  
**C. W. Ireland**, National Oilwell Varco

**J. M. Klibert**, Lift-All Co., Inc.  
**R. W. Parry**, Consultant

## B30.9 SUBCOMMITTEE PERSONNEL

**R. M. Parnell**, *Chair*, ITT-Field Service  
**A. Abraham**, Samson Rope Technologies  
**N. E. Andrew**, LTS Cranes  
**B. B. Bacon**, Tennessee Valley Authority  
**T. Blanton**, NACB Group, Inc.  
**P. A. Boeckman**, The Crosby Group  
**P. Cooke**, CM  
**D. R. Decker**, Becket, LLC  
**G. J. D'Elia**, Slingmax Rigging Solutions  
**D. Fabula**, Department of the Navy  
**M. J. Gelskey**, Lift It Manufacturing Co., Inc.  
**J. A. Gilbert**, Associates Wire Rope Fabricators  
**S. R. Gridley**, Navy Crane Center  
**P. S. Hughes**, MAGNA Lifting

**T. W. Klein**, Wireco Worldgroup  
**M. A. Kowalick**, Liftext Corp.  
**L. D. Means**, Means Engineering & Consulting  
**D. A. Moore**, Unified Engineering  
**M. Neuzil**, Six Flags  
**B. D. Todd**, Campbell Chain  
**D. Beltran**, *Alternate*, Gunnebo Johnson Corp.  
**R. Marcotte**, *Alternate*, Industrial Training International  
**R. Ohman III**, *Alternate*, The Crosby Group  
**T. Raines, Jr.**, *Alternate*, CMCO  
**M. Riggs**, *Alternate*, Rigging Institute, LLC  
**J. Schroeder**, *Alternate*, RUD Chain  
**L. R. Townsend**, *Alternate*, FIRST Sling Technology, LLC

## B30 INTEREST REVIEW GROUP

**O. Akinboboye**, Ropetech Engineering Services  
**D. Beltran**, Gunnebo Johnson Corp.  
**J. D. Cannon**, U.S. Army Corps of Engineers  
**B. Dobbs**, LEEA  
**M. J. Eggenberger**, Berry Contracting, Inc.  
**A. Gomes Rocha**, Belgo Bekaert Arames  
**H. A. Hashem**, Saudi Aramco  
**J. Hui**, Si Pai Lou, School of Civil Engineering

**C. Lan**, Department of Industry — BSEE  
**A. C. Mattoli**, Prowinch, LLC  
**J. P. Mihlbauer**, All Ship & Cargo Surveys, Ltd.  
**L. S. Olver**, Kolo Holdings, Inc.  
**G. L. Owens**, Consultant  
**D. R. Remus**, Reed Manufacturing  
**C. C. Tsaur**, Institute of Occupational Safety and Health

## B30 REGULATORY AUTHORITY COUNCIL

**C. Shelhamer**, *Chair*, New York City Department of Buildings  
**K. M. Hyam**, *Secretary*, The American Society of Mechanical Engineers  
**L. G. Champion**, Department of Labor/OSHA  
**R. Feidt**, Stephenson Equipment, Inc.  
**C. Harris**, City of Chicago — Department of Buildings  
**R. D. Jackson**, U.S. Department of Labor  
**J. L. Lankford**, State of Nevada (OSHA)  
**D. E. Latham**, State of Maryland DLLR  
**A. Lundeen**, State of Washington, Department of Labor and Industries

**J. Mendoza**, North Carolina Department of Labor, Division of Occupational Safety  
**M. J. Nelmda**, State of California, Occupational Safety and Health Standards Board  
**G. E. Pushies**, MIOSHA  
**C. N. Stribling, Jr.**, Kentucky Labor Cabinet  
**T. Taylor**, Minnesota Department of Labor & Industry  
**A. O. Omran**, *Alternate*, New York City Department of Buildings  
**K. L. Powell**, *Alternate*, Maryland Department of Labor, MOSH



# آریا ایمن آوات

## B30 STANDARD INTRODUCTION

### SECTION I: SCOPE

The ASME B30 Standard contains provisions that apply to the construction, installation, operation, inspection, testing, maintenance, and use of cranes and other lifting and material-movement-related equipment. For the convenience of the reader, the Standard has been divided into separate volumes. Each volume has been written under the direction of the ASME B30 Standards Committee and has successfully completed a consensus approval process under the general auspices of the American National Standards Institute (ANSI).

As of the date of issuance of this Volume, the B30 Standard comprises the following volumes:

- B30.1 Jacks, Industrial Rollers, Air Casters, and Hydraulic Gantries
- B30.2 Overhead and Gantry Cranes (Top Running Bridge, Single or Multiple Girder, Top Running Trolley Hoist)
- B30.3 Tower Cranes
- B30.4 Portal and Pedestal Cranes
- B30.5 Mobile and Locomotive Cranes
- B30.6 Derricks
- B30.7 Winches
- B30.8 Floating Cranes and Floating Derricks
- B30.9 Slings
- B30.10 Hooks
- B30.11 Monorails and Underhung Cranes (withdrawn 2018 — requirements found in B30.17)
- B30.12 Handling Loads Suspended From Rotorcraft
- B30.13 Storage/Retrieval (S/R) Machines and Associated Equipment
- B30.14 Side Boom Tractors
- B30.15 Mobile Hydraulic Cranes (withdrawn 1982 — requirements found in latest revision of B30.5)
- B30.16 Overhead Underhung and Stationary Hoists
- B30.17 Cranes and Monorails (With Underhung Trolley or Bridge)
- B30.18 Stacker Cranes (Top or Under Running Bridge, Multiple Girder With Top or Under Running Trolley Hoist)
- B30.19 Cableways
- B30.20 Below-the-Hook Lifting Devices

- B30.21 Lever Hoists
- B30.22 Articulating Boom Cranes
- B30.23 Personnel Lifting Systems
- B30.24 Container Cranes
- B30.25 Scrap and Material Handlers
- B30.26 Rigging Hardware
- B30.27 Material Placement Systems
- B30.28 Balance Lifting Units
- B30.29 Self-Erecting Tower Cranes
- B30.30 Ropes<sup>1</sup>
- B30.31 Self-Propelled, Towed, or Remote-Controlled Hydraulic Platform Transporters<sup>1</sup>
- B30.32 Unmanned Aircraft Systems (UAS) Used in Inspection, Testing, Maintenance, and Lifting Operations<sup>1</sup>

### SECTION II: SCOPE EXCLUSIONS

Any exclusion of, or limitations applicable to, the equipment, requirements, recommendations, or operations contained in this Standard are established in the affected volume's scope.

### SECTION III: PURPOSE

The B30 Standard is intended to

- (a) prevent or minimize injury to workers, and otherwise provide for the protection of life, limb, and property by prescribing safety requirements
- (b) provide direction to manufacturers, owners, employers, users, and others concerned with, or responsible for, its application
- (c) guide governments and other regulatory bodies in the development, promulgation, and enforcement of appropriate safety directives

### SECTION IV: USE BY REGULATORY AGENCIES

These volumes may be adopted in whole or in part for governmental or regulatory use. If adopted for governmental use, the references to other national codes and standards in the specific volumes may be changed to refer to the corresponding regulations of the governmental authorities.

<sup>1</sup>This volume is currently in the development process.



## EFFECTIVE DATE

*Effective Date.* The effective date of this Volume of the B30 Standard shall be 1 yr after its date of issuance. Construction, installation, inspection, testing, maintenance, and operation of equipment manufactured and facilities constructed after the effective date of this Volume shall conform to the mandatory requirements of this Volume.

(b) *Existing Installations.* Equipment manufactured and facilities constructed prior to the effective date of this Volume of the B30 Standard shall be subject to the inspection, testing, maintenance, and operation requirements of this Standard after the effective date.

It is not the intent of this Volume of the B30 Standard to require retrofitting of existing equipment. However, when an item is being modified, its performance requirements shall be reviewed relative to the requirements within the current volume. The need to meet the current requirements shall be evaluated by a qualified person selected by the owner (user). Recommended changes shall be made by the owner (user) within 1 yr.

## SECTION VI: REQUIREMENTS AND RECOMMENDATIONS

Requirements of this Standard are characterized by use of the word *shall*. Recommendations of this Standard are characterized by the word *should*.

## SECTION VII: USE OF MEASUREMENT UNITS

This Standard contains SI (metric) units as well as U.S. Customary units. The values stated in U.S. Customary units are to be regarded as the standard. The SI units are a direct (soft) conversion from the U.S. Customary units.

## SECTION VIII: REQUESTS FOR REVISION

The B30 Standards Committee will consider requests for revision of any of the volumes within the B30 Standard. Such requests should be directed to

Secretary, B30 Standards Committee  
ASME Codes and Standards  
Two Park Avenue  
New York, NY 10016-5990

Requests should be in the following format:

- Volume: Cite the designation and title of the volume.
- Edition: Cite the applicable edition of the volume.
- Subject: Cite the applicable paragraph number(s) and the relevant heading(s).
- Request: Indicate the suggested revision.
- Rationale: State the rationale for the suggested revision.

Upon receipt by the Secretary, the request will be forwarded to the relevant B30 Subcommittee for consideration and action. Correspondence will be provided to the requester defining the actions undertaken by the B30 Standards Committee.

## SECTION IX: REQUESTS FOR INTERPRETATION

The B30 Standards Committee will render an interpretation of the provisions of the B30 Standard. An Interpretation Submittal Form is available on ASME's website at <http://cstools.asme.org/Interpretation/InterpretationForm.cfm>.

Phrase the question as a request for an interpretation of a specific provision suitable for general understanding and use, not as a request for approval of a proprietary design or situation. Plans or drawings that explain the question may be submitted to clarify the question. However, they should not contain any proprietary names or information. Read carefully the note addressing the types of requests that the B30 Standards Committee can and cannot consider.

Upon submittal, the request will be forwarded to the relevant B30 Subcommittee for a draft response, which will then be subject to approval by the B30 Standards Committee prior to its formal issuance. The B30 Standards Committee may rewrite the question for the sake of clarity.

Interpretations to the B30 Standard will be available online at <https://cstools.asme.org/Interpretation/SearchInterpretation.cfm>.

## SECTION X: ADDITIONAL GUIDANCE

The equipment covered by the B30 Standard is subject to hazards that cannot be abated by mechanical means, but only by the exercise of intelligence, care, and common sense. It is therefore essential to have personnel involved in the use and operation of equipment who are competent, careful, physically and mentally qualified, and trained in the proper operation of the equipment and the handling of loads. Serious hazards include, but are not limited to, improper or inadequate maintenance, overloading, dropping or slipping of the load, obstructing the free passage of the load, and using equipment for a purpose for which it was not intended or designed.

The B30 Standards Committee fully realizes the importance of proper design factors, minimum or maximum dimensions, and other limiting criteria of wire rope or chain and their fastenings, sheaves, sprockets, drums, and similar equipment covered by the Standard, all of which are closely connected with safety. Sizes, strengths, and similar criteria are dependent on many different factors, often varying with the installation and uses. These factors depend on

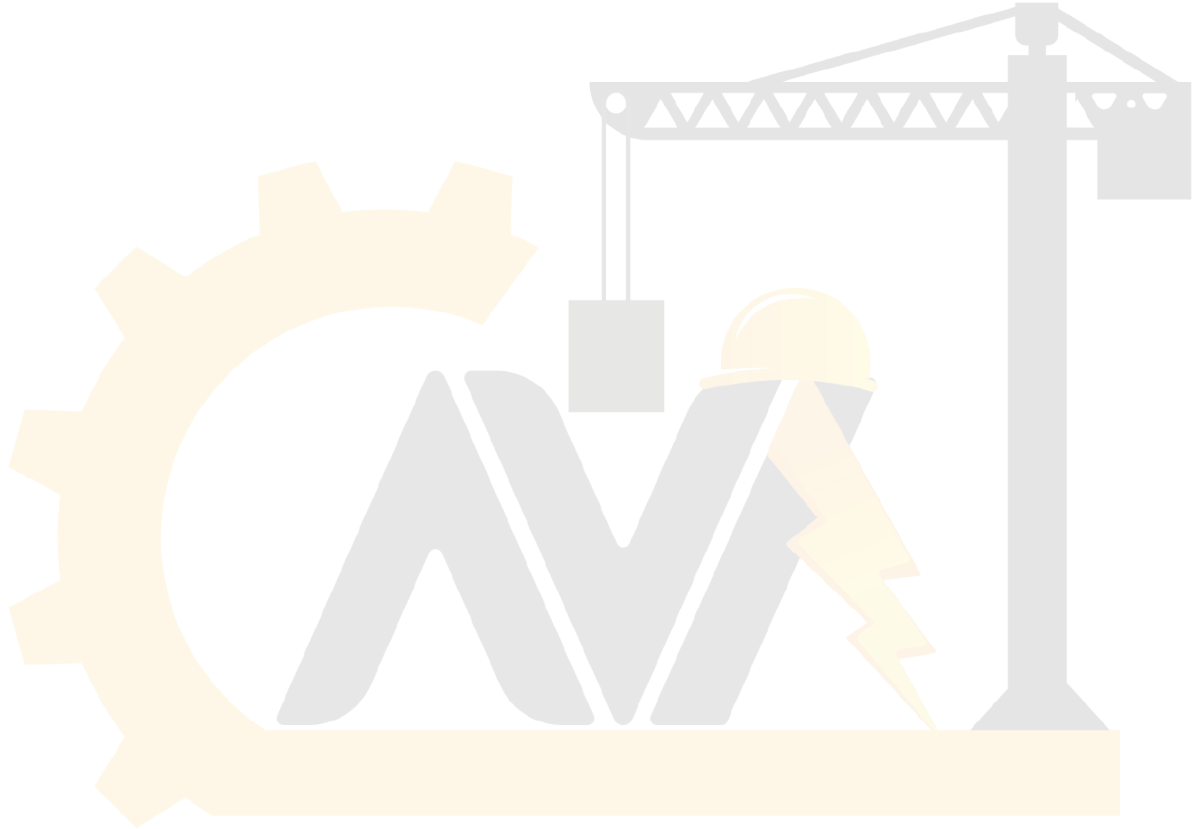
- (a) the condition of the equipment or material
- (b) the loads



- (d) acceleration or speed of the ropes, chains, sprockets, or drums
- (e) the type of attachments
- (e) the number, size, and arrangement of sheaves or other parts
- (f) environmental conditions causing corrosion or wear

(g) many variables that must be considered in each individual case

The requirements and recommendations provided in the volumes must be interpreted accordingly, and judgment used in determining their application.



آریا ایمن آوات

## ASME B30.9-2018 SUMMARY OF CHANGES

Following approval by the ASME B30 Committee and ASME, and after public review, ASME B30.9-2018 was approved by the American National Standards Institute on March 23, 2018.

ASME B30.9-2018 includes the following changes identified by a margin note, **(18)**.

<i>Page</i>	<i>Location</i>	<i>Change</i>
	B30 Standard Introduction	Revised
1	9-0.1	Revised
1	9-0.2	(1) Definitions for <i>denier</i> , <i>high tenacity fiber</i> , <i>original language(s)</i> , <i>shall</i> , <i>should</i> , and <i>tenacity</i> added (2) Definitions for <i>design factor</i> , <i>endless sling (wire rope)</i> , <i>grommet (wire rope)</i> , <i>proof load</i> , and <i>service</i> revised
3	9-0.4	Added, and subsequent paragraphs redesignated
3	9-0.5	Revised in its entirety
3	9-0.6	Updated
5	9-1.2.3	Revised
7	9-1.9.1	Revised
8	9-1.9.3	Subparagraph (a) revised
8	9-1.9.4	(1) Subparagraph (b) revised (2) Subparagraph (d) added, and subsequent subparagraph redesignated
11	9-2.2.2	Subparagraph (e) added
11	9-2.2.3	Revised
11	9-2.3.1	Revised in its entirety
14	9-2.9.1	Revised
14	9-2.9.3	Subparagraph (a) revised
14	9-2.9.4	(1) Subparagraph (b) revised (2) Subparagraph (d) added, and subsequent subparagraphs redesignated
16	9-2.10.4	Subparagraph (r) deleted
18	9-3.2.2	Subparagraph (b) revised
18	9-3.2.3	Revised
20	9-3.9.1	Revised
20	9-3.9.3	Subparagraph (a) revised
20	9-3.9.4	(1) Subparagraph (b) revised (2) Subparagraph (d) added, and subsequent subparagraph redesignated

	9-4.2.2	Subparagraph (d) revised
	9-4.2.3	Revised
24	Figure 9-4.0-1	Revised
26	9-4.9.1	Revised
26	9-4.9.3	Subparagraph (a) revised
26	9-4.9.4	(1) Subparagraph (b) revised (2) Subparagraph (d) added, and subsequent subparagraphs redesignated
28	9-4.10.3	Subparagraph (d) revised
30	9-5.2.3	Subparagraph (b) revised
30	9-5.2.4	Revised
32	9-5.9.1	Revised
32	9-5.9.3	Subparagraph (a) revised
32	9-5.9.4	(1) Subparagraph (b) revised (2) Subparagraph (d) added, and subsequent subparagraphs redesignated
34	9-5.10.3	Subparagraph (c) revised
35	9-6.2.1	Revised
35	9-6.2.2	Subparagraph (b) revised
35	9-6.2.3	Revised
37	9-6.9.1	Revised
37	9-6.9.3	Subparagraph (a) revised
37	9-6.9.4	(1) Subparagraph (b) revised (2) Subparagraph (d) added, and subsequent subparagraphs redesignated
37	9-6.9.5	Subparagraph (g) revised
38	9-6.10.1	Subparagraphs (j) and (k) combined and revised, and subsequent subparagraph redesignated
38	9-6.10.3	Subparagraph (b) revised
39	9-6.10.4	Subparagraph (d) revised
40	Chapter 9-7	Added





# آریا ایمن آوات

## Chapter 9-0

# Scope, Definitions, Personnel Competence, Rigger Responsibilities, Translations, and References

(18) **SECTION 9-0.1: SCOPE OF ASME B30.9**

Volume B30.9 includes provisions that apply to the fabrication, attachment, use, inspection, testing, and maintenance of slings used for load-handling purposes, used in conjunction with equipment described in other volumes of the B30 Standard, except as restricted in ASME B30.12 and ASME B30.23. Slings fabricated from alloy steel chain, wire rope, metal mesh, synthetic fiber rope, synthetic webbing, and polyester and high performance fiber yarns in a cover(s) are addressed.

(18) **SECTION 9-0.2: DEFINITIONS**

*abnormal operating conditions*: environmental conditions that are unfavorable, harmful, or detrimental to or for the operation of a sling such as excessively high or low ambient temperatures, exposure to weather, corrosive fumes, dust-laden or moisture-laden atmospheres, and hazardous locations.

*abrasion*: the mechanical wearing of a surface resulting from frictional contact with other materials or objects.

*angle of choke*: the angle formed in a sling body as it passes through the choking eye or fittings.

*angle of loading*: the acute angle between the sling leg and the plane perpendicular to the direction of applied force, sometimes referred to as *horizontal angle* when lifting (see Figure 9-1.5-1).

*basket hitch*: a method of rigging a sling in which the sling is passed around the load, and both eye openings or end fittings are attached to a hook, shackle(s), or other load-handling device.

*body (sling)*: that part of a sling between the eyes, end fittings, or loop eyes.

*braided wire rope*: a rope formed by plaiting component wire ropes.

*braided wire rope sling*: a sling made from braided rope.

*bridle sling*: a sling composed of multiple legs with the top ends gathered in a fitting that attaches to a hook, shackle, or other load-handling device.

*cable-laid rope*: a type of wire rope composed of six individual wire ropes laid as strands around a wire rope core.

*cable-laid rope sling, mechanical joint*: a wire rope sling made from a cable-laid wire rope with eyes fabricated by swaging one or more metal sleeves over each rope junction.

*choker hitch*: a method of rigging a sling in which one end of the sling is passed around the load, then through itself, an eye opening, an end fitting, or other device, and attached to a hook, shackle, or other load-handling device.

*component*: any load-bearing element of the sling including the chain, wire rope, metal mesh, synthetic rope, synthetic webbing, roundsling core yarns, thread, and fittings, as applicable.

*component strength*: the published or industry accepted minimum breaking strength or minimum breaking force of the weakest component of the sling.

*coupling link*:

*mechanical coupling link*: a nonwelded cross-pinned link used as a connector to join a sling leg to a fitting.

*welded coupling link*: an alloy steel welded link used as a connector to join alloy steel chain to another component of the sling

*cross rod*: a wire used to join spirals of metal mesh to form the complete fabric.

*D/d ratio*: the ratio between the curvature taken by the sling,  $D$ , and the diameter of the wire rope, synthetic rope, or chain,  $d$ .

*denier*: a mass-per-unit-length measure equal to the weight in grams of 9 000 m of the material. Denier is a direct numbering system in which the lower numbers represent the finer sizes and the higher numbers the coarser sizes.

*design factor*: the ratio between the designed breaking load of the fabricated sling and the rated load of the sling.

*designed breaking load*: the minimum load at which a newly fabricated and unused sling is expected to break when loaded to destruction in direct tension.

*endless sling (wire rope)*: a wire rope sling made endless from one continuous length of cable-laid or strand-laid rope with ends joined by one or more metallic fittings (mechanical joint).



the opening in the end of a sling for the attachment, hook, shackle, or other load-handling device or itself.

*fabric (metal mesh)*: the flexible portion of the sling exclusive of end fittings consisting of a series of transverse spirals and cross rods.

*fabric length (metal mesh)*: the distance of metal mesh between the end fittings.

*fabric thickness (metal mesh)*: the nominal overall thickness of the spirals.

*fabrication efficiency*: the strength of the fabricated sling, as a percentage of the material strength prior to fabrication.

*fitting*: any load-bearing hardware used to fabricate the sling such as a swage sleeve for wire rope or a coupling link for alloy chain, or an end attachment such as a hook or master link.

*flemish eye splice*: a mechanical splice formed by unlaying the wire rope body into two parts and reforming it to create a loop or eye. The splice is completed by pressing (swaging) a metal sleeve over the rope juncture.

*grommet (wire rope)*: a wire rope sling made endless from one continuous strand (strand-laid) formed to make a six-strand rope with a strand core, or one continuous rope (cable-laid) formed to make a body of six ropes around a rope core. The strand or rope ends (as applicable) are hand-tucked into the body.

*hand-tucked splice (wire rope and synthetic rope)*: a loop or eye formed in the end of a rope by tucking the ends of the strands back into the main body of the rope in a prescribed manner.

*high tenacity fiber*: fiber that has a tenacity of 15 g per denier or higher.

*hitch (hitched)*: a method of rigging (attaching) a sling temporarily to a load or object for the purpose of load handling.

*load-bearing splice (web sling)*: that part of a sling that is lapped and secured to become an integral load-bearing part of the sling.

*load handling*: the act of lifting or pulling a load from one location to another by using a sling as the connector between the load and the load-handling equipment.

*loop eye (web sling)*: the opening formed when a length of webbing is folded back upon itself and sewn to the sling body, thereby forming a bearing point.

*master coupling link*: an alloy steel welded coupling link used as an intermediate connector to join alloy steel chain to a master link.

*master link*: a link used to gather the leg(s) of a sling.

*mechanical splice (wire rope)*: a splice formed by swaging one or more metal sleeves over the wire rope to form a loop or eye.

*original language(s)*: language(s) used by the manufacturer to develop and verify product instructions and manual(s).

*ply*: a layer of load-bearing webbing used in a synthetic webbing sling.

*poured socket*: a fitting into which a broomed and degreased wire rope is inserted. The wire rope is then secured within the socket by filling the socket bowl with special molten metal or resin materials.

*proofload*: the specific load applied in the performance of a proof test.

*proof test*: a nondestructive tension test of the sling or components.

*qualified person*: a person who, by possession of a recognized degree or certificate of professional standing in an applicable field, or who, by extensive knowledge, training, and experience, has successfully demonstrated the ability to solve or resolve problems relating to the subject matter and work.

*rated load*: the maximum allowable working load established by the sling manufacturer. The terms *rated capacity* and *working load limit* are commonly used to describe rated load.

*reach (alloy steel chain sling)*: see *sling length*.

*return loop*: see *turnback swaged eye splice (wire rope)*.

*service*:

*normal*: service that involves handling of loads within the rated load.

*severe*: service that involves normal service coupled with abnormal operating conditions.

*special*: service that involves operation, other than normal or severe, that is identified by a qualified person.

*shall*: a word indicating a requirement.

*shock load*: a momentary increase in the force applied to a sling caused by the sudden movement, shifting, or arresting of a load.

*short splice (synthetic rope endless sling)*: a splice formed by joining the two opposite rope ends by tucking the strands into the main body of the rope in a prescribed manner.

*should*: a word indicating a recommendation.

*sling*: an assembly as described in this Volume used for load handling.

*sling body*: see *body (sling)*.

*sling length*: the distance between the extreme bearing points of the sling assembly, except that the length dimension for wire rope slings excludes the gathering ring or master link in the length dimension.



*manufacturer (fabricator)*: a person or company making or fabricating the sling(s). The sling manufacturer and the manufacturer of the sling components may or may not be the same entity.

*spiral (metal mesh)*: a single transverse coil of wire that is the basic element from which metal mesh is fabricated.

*straight-line hitch*: a method of rigging a sling in which an eye opening, end fitting, or one end of the sling is attached to the load, and the other eye opening, end fitting, or end of the sling is attached to a hook, shackle, or other load-handling device.

*strand-laid rope*: a wire rope made with strands (usually six to eight) formed around a fiber core, wire strand core, or independent wire rope core (IWRC).

*swaged socket*: an end fitting into which a wire rope is inserted and then permanently attached by mechanical compression applied to the socket shank.

*tenacity*: measurement of strength of the fiber or yarn where strength is defined as the force divided by the linear density. This is typically expressed as grams force per denier (gpd).

*turnback swaged eye splice (wire rope)*: a mechanical splice in which the rope is looped back on itself and secured with one or more metal sleeves. The term *return loop* is commonly used to describe a turnback swaged eye.

*vertical hitch*: see *straight-line hitch*.

*yarn*: a generic term for a continuous strand of fibers.

### SECTION 9-0.3: PERSONNEL COMPETENCE

Persons performing the functions identified in this Volume shall meet the applicable qualifying criteria stated in this Volume and shall, through education, training, experience, skill, and physical ability, as necessary, be competent and capable to perform the functions as determined by the employer or employer's representative.

### (18) SECTION 9-0.4: RIGGER RESPONSIBILITIES

Riggers assigned to a load-handling activity shall, at a minimum, be responsible for

(a) ensuring the weight of the load and its approximate center of gravity have been obtained, provided, or calculated

(b) selecting the proper rigging equipment, inspecting it, and complying with the applicable operating practices according to the criteria of the applicable ASME B30 volume (i.e., B30.9, B30.10, B30.20, B30.23, B30.26)

(c) ensuring the rated load of the rigging equipment as selected and configured is sufficient for the load to be handled, based on the number of legs, hitch configuration, and effects of angles

(d) properly attaching the rigging equipment to the hook, shackle, or other load-handling device

(e) ensuring that rigging equipment is adequately protected from abrasion, cutting, or other damage during load-handling activities

(f) rigging the load in a manner to ensure balance and stability during the load-handling activity

(g) knowing and understanding the applicable signals for the equipment in use

(h) installing and using a tag line(s) when additional load control is required

### SECTION 9-0.5: ORIGINAL AND TRANSLATED TECHNICAL AND SAFETY-RELATED INFORMATION (18)

(a) If the manufacturer provides instructions [manual(s), warnings labels, usage decals, etc.] for the operation, inspection, and maintenance of the sling

(1) the instructions shall be provided in a language specified by the purchaser at the time of the initial sale by the manufacturer

(2) any pictograms used shall be described in the instructions, and the pictograms should comply with ISO 7000, ISO 7296, or other recognized source, if previously defined

(b) If the original language instructions are translated, the process shall meet professional translation industry standards, which include, but are not limited to, the following:

(1) translating the complete paragraph message, instead of word by word

(2) ensuring grammatical accuracy

(3) preserving the source document content without omitting or expanding the text

(4) translating the terminology accurately

(5) reflecting the level of sophistication of the original document

(c) If the original language instructions are translated, the finished translation shall be verified for compliance with (b)(1) through (b)(5) by a qualified person having an understanding of the technical content of the subject matter.

### SECTION 9-0.6: REFERENCES (18)

The following is a list of publications referenced in this Standard:

ASME B30.10-2014, Hooks

ASME B30.12-2011, Handling Loads Suspended From Rotorcraft

ASME B30.20-2013, Below-the-Hook Lifting Devices

ASME B30.23-2011, Personnel Lifting Systems

ASME B30.26-2015, Rigging Hardware



American Society of Mechanical Engineers  
Two Park Avenue, New York, NY 10016-5990  
(www.asme.org)

ASTM A391/A391M-01, Standard Specification for Grade 80 Alloy Steel Chain  
ASTM A586-98, Standard Specification for Zinc-Coated Parallel and Helical Steel Wire Structural Strand and Zinc-Coated Wire for Spun-in-Place Structural Strand  
ASTM A906/A906M-02, Standard Specification for Grade 80 and Grade 100 Alloy Steel Chain Slings for Overhead Lifting  
ASTM A952/A952M-02, Standard Specification for Forged Grade 80 and Grade 100 Steel Lifting Components and Welded Attachment Links  
ASTM A973/A973M-01, Standard Specification for Grade 100 Alloy Steel Chain  
ASTM A1023/A1023M-02, Standard Specification for Stranded Carbon Steel Wire Ropes for General Purposes  
Publisher: American Society for Testing and Materials (ASTM International), 100 Barr Harbor Drive, P.O. Box C700, West Conshohocken, PA 19428-2959 (www.astm.org)  
CI 1303-06, Nylon (Polyamide) Fiber Rope, 3-Strand and 8-Strand Construction  
CI 1304-08, Polyester (PET) Fiber Rope, 3-Strand and 8-Strand Construction

CI 1305-09, Single Braided Polyester Fiber Rope, 12-Strand Braid Construction  
CI 1310-09, Nylon (Polyamide) Fiber Rope, Double Braid Construction  
CI 1311-09, Polyester (PET) Fiber Rope, Double Braid Construction  
CI 1905-14, Synthetic Roundslings  
CI 2001-04, Fiber Rope Inspection and Retirement Criteria  
Publisher: The Cordage Institute (CI), 994 Old Eagle School Road, Wayne, PA 19087 (www.ropecord.com)

Wire Rope Sling Users Manual, 3rd Edition  
Publisher: Wire Rope Technical Board (WRTB), P.O. Box 151387, Alexandria, VA 22315-1387 (www.wireropetechnicalboard.org)

WSTDA-RS-1-2010, Recommended Standard Specification for Synthetic Polyester Roundslings  
WSTDA-TH-1-2015, Recommended Standard Specification for Synthetic Thread  
WSTDA-UV-Sling-2003, Summary Report UV Degradation  
WSTDA-WB-1-2015, Recommended Standard Specification for Synthetic Webbing for Slings  
Publisher: Web Sling & Tie Down Association (WSTDA), 2105 Laurel Bush Road, Bel Air, MD 21015 (www.wstda.com)

آریا ایمن آوات

# Chapter 9-1

## Alloy Steel Chain Slings: Selection, Use, and Maintenance

### SECTION 9-1.0: SCOPE

Chapter 9-1 includes provisions that apply to alloy steel chain slings (see Figure 9-1.0-1).

### SECTION 9-1.1: TRAINING

Alloy steel chain sling users shall be trained in the selection, inspection, cautions to personnel, effects of environment, and rigging practices as covered by this Chapter.

### SECTION 9-1.2: COMPONENTS

#### 9-1.2.1 Alloy Chain

The alloy steel chain shall be manufactured and tested in accordance with ASTM A391/A391M for Grade 80 chain and ASTM A973/A973M for Grade 100 chain.

#### 9-1.2.2 Fittings

(a) Fittings for alloy steel chain slings shall be manufactured and tested in accordance with ASTM A952/A952M.

(b) Makeshift fasteners, hooks, or links formed from bolts, rods, or other such fittings shall not be used.

(c) Where used, handles shall be welded to the master link or hook prior to heat treating according to the recommendations of the sling manufacturer or a qualified person.

(d) When employed, hooks other than those described in ASTM A952/A952M shall meet the requirements of ASME B30.10.

(e) When employed, rigging hardware other than master links described in ASTM A952/A952M shall meet the requirements of ASME B30.26.

#### (18) 9-1.2.3 Other Components

Slings that employ chain or fittings other than those listed in paras. 9-1.2.1 and 9-1.2.2 may be used. When such components are employed, the sling manufacturer or a qualified person shall provide specific data regarding deviations from the applicable sections of this Chapter. These slings shall comply with all other requirements of this Chapter.

### SECTION 9-1.3: FABRICATION AND CONFIGURATIONS

#### 9-1.3.1 Fabrication

(a) Grade 80 and Grade 100 alloy steel chain slings shall be fabricated in accordance with ASTM A906/A906M.

(b) Mechanical coupling links shall not be used within the body of an alloy chain sling to connect two pieces of chain.

#### 9-1.3.2 Configurations

(a) Single-leg slings and double-leg, triple-leg, and quadruple-leg bridle slings used in straight-line, choker, and basket hitches are covered in this Chapter.

NOTE: A straight-line hitch is commonly referred to as a vertical hitch.

(b) Single- and double-basket slings used in basket hitches are covered in this Chapter.

(c) Other configurations may be used. When used, the sling manufacturer or a qualified person shall provide specific data. These slings shall comply with all other requirements of this Chapter.

### SECTION 9-1.4: DESIGN FACTOR

The design factor for alloy steel chain slings shall be a minimum of 4.

### SECTION 9-1.5: RATED LOAD

(a) The sling manufacturer shall establish the sling's rated load.

(b) At a minimum, the rated load shall be based on the following factors:

(1) component strength

(2) number of legs

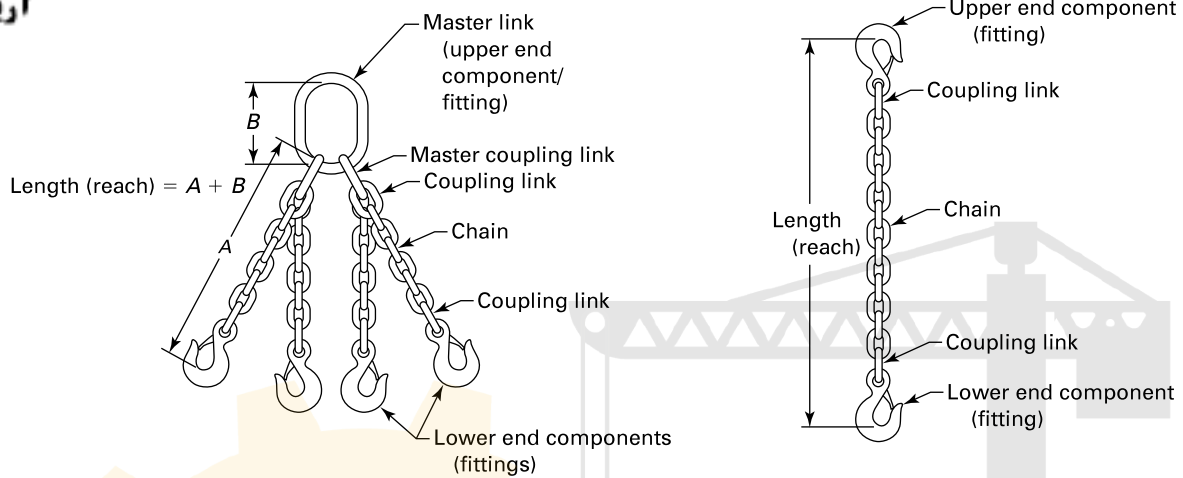
(3) design factor

(4) type of hitch (see Figure 9-1.0-1)

(5) angle of loading (see Figure 9-1.5-1)

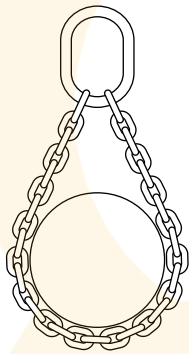
(c) The rated load of a quadruple-leg or double-basket sling shall not exceed the rated load of a triple-leg sling.

**Figure 9-1.0-1 Alloy Steel Chain Slings: Configurations, Components, and Hitches**

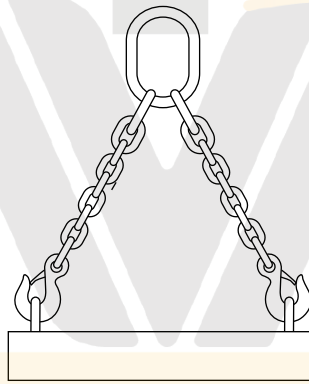


**(a) Quadruple-Leg Bridle Sling Components**

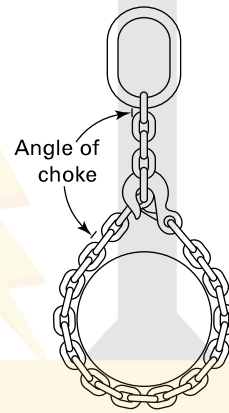
**(b) Single-Leg Sling Components**



**(c) Single-Basket Sling and Hitch**



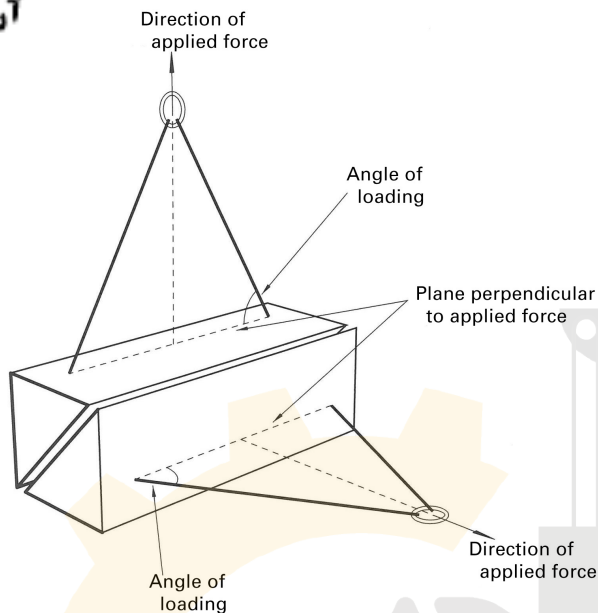
**(d) Double-Leg Bridle Sling Hitch**



**(e) Single-Leg Choker Hitch**

آریا ایمن آوات

**Figure 9-1.5-1 Angle of Loading**



## SECTION 9-1.6: PROOF TEST REQUIREMENTS

### 9-1.6.1 General

Prior to initial use, all new and repaired chain and fittings of an alloy steel chain sling shall be proof tested either individually or as an assembly by the sling manufacturer or a qualified person.

### 9-1.6.2 Proof Load Requirements

(a) For single- or multiple-leg slings, each leg shall be proof loaded to a minimum of 2 times the single-leg straight-line hitch rated load.

(b) The proof load for fittings attached to single legs shall be a minimum of 2 times the single-leg straight-line hitch rated load.

(c) Master links for double-leg bridle slings, single-basket slings, and master coupling links connected to two legs shall be proof loaded to a minimum of 4 times the single-leg straight-line hitch rated load.

(d) Master links for triple- and quadruple-leg bridle slings and double-basket bridle slings shall be proof loaded to a minimum of 6 times the single-leg straight-line hitch rated load.

## SECTION 9-1.7: SLING IDENTIFICATION

### 9-1.7.1 Identification Requirements

Each sling shall be marked to show

(a) name or trademark of manufacturer, or if repaired, the entity performing repairs

(b) grade

(c) nominal chain size

(d) number of legs

(e) rated load for at least one hitch type and the angle upon which it is based

(f) length (reach)

(g) individual sling identification (e.g., serial number)

### 9-1.7.2 Initial Sling Identification

Sling identification shall be done by the sling manufacturer.

### 9-1.7.3 Maintenance of Sling Identification

Sling identification should be maintained by the user so as to be legible during the life of the sling.

### 9-1.7.4 Replacement of Sling Identification

Replacement of the sling identification shall be considered a repair as specified in [paras. 9-1.9.6\(a\)](#) and [9-1.9.6\(b\)](#). Additional proof testing is not required.

## SECTION 9-1.8: EFFECTS OF ENVIRONMENT

### 9-1.8.1 Temperature

Extreme temperatures may reduce the performance of alloy steel chain slings. The sling manufacturer should be consulted when the slings are to be used in temperatures of  $-40^{\circ}\text{F}$  ( $-40^{\circ}\text{C}$ ) or below. Rated load reductions for Grade 80 and Grade 100 alloy chain slings used at or after exposure to temperatures of  $400^{\circ}\text{F}$  ( $204^{\circ}\text{C}$ ) or higher are given in [Table 9-1.8.1-1](#).

### 9-1.8.2 Chemically Active Environments

The strength of alloy steel chain slings may be degraded by chemically active environments. This includes exposure to chemicals in the form of solids, liquids, gases, vapors, or fumes. The sling manufacturer or a qualified person should be consulted before slings are used in chemically active environments.

## SECTION 9-1.9: INSPECTION, REMOVAL, AND REPAIR

### 9-1.9.1 General

(18)

All inspections shall be performed by a designated person. Any deficiency identified shall be examined and a determination made by a qualified person as to whether it constitutes a hazard, and if so, what additional steps need to be taken to address the hazard.

### 9-1.9.2 Initial Inspection

Prior to use, each new, altered, modified, or repaired sling shall be inspected to verify compliance with the applicable provisions of this Chapter. A written record





**Table 9-1.8.1-1 Effect of Elevated Temperature on Rated Load of Alloy Steel Chain**

Temperature		Grade of Chain			
		Grade 80		Grade 100	
°F	°C	Temporary Reduction of Rated Load While at Temperature	Permanent Reduction of Rated Load After Exposure to Temperature	Temporary Reduction of Rated Load While at Temperature	Permanent Reduction of Rated Load After Exposure to Temperature
Below 400	Below 204	None	None	None	None
400	204	10%	None	15%	None
500	260	15%	None	25%	5%
600	316	20%	5%	30%	15%
700	371	30%	10%	40%	20%
800	427	40%	15%	50%	25%
900	482	50%	20%	60%	30%
1,000	538	60%	25%	70%	35%
Over 1,000	Over 538	Note (1)	Note (1)	Note (1)	Note (1)

NOTE: (1) Remove from service.

of the inspection referencing the individual sling identification is required.

**(18) 9-1.9.3 Frequent Inspection**

(a) Each shift, before the sling is used, a visual inspection for damage shall be performed. Slings used in severe or special service should be inspected before each use.

(b) Slings found with conditions such as those listed in para. 9-1.9.5 shall be removed from service. Slings shall not be returned to service until approved by a qualified person.

(c) Written records are not required for frequent inspections.

**(18) 9-1.9.4 Periodic Inspection**

(a) A complete inspection of the sling shall be performed. Each link and fitting shall be examined individually, taking care to expose and examine all surfaces, including the inner link surfaces. Slings found with conditions such as those listed in para. 9-1.9.5 shall be removed from service. Slings shall not be returned to service until approved by a qualified person.

(b) *Periodic Inspection Frequency.* Periodic inspection intervals shall not exceed 1 yr [see (d)]. The frequency of periodic inspections should be based on

- (1) frequency of sling use
- (2) severity of service conditions
- (3) nature of load-handling activities
- (4) experience gained on the service life of slings used in similar circumstances

(c) Guidelines for the time intervals are

- (1) normal service — yearly
- (2) severe service — monthly to quarterly
- (3) special service — as recommended by a qualified person

(d) Periodic inspection is not required for a sling that is in storage or idle. However, if more than 1 yr has passed since the last periodic inspection, the sling shall be inspected in accordance with the requirements listed in (a) and (e) before being placed back into service.

(e) A written record of the most recent periodic inspection shall be maintained and shall include the condition of the sling.

**9-1.9.5 Removal Criteria**

An alloy steel chain sling shall be removed from service if any of the following conditions are present:

- (a) missing or illegible sling identification (see Section 9-1.7).
- (b) cracks or breaks.
- (c) excessive wear, nicks, or gouges. Minimum thickness on chain links shall not be below the values listed in Table 9-1.9.5-1.
- (d) stretched chain links or fittings.
- (e) bent, twisted, or deformed chain links or fittings.
- (f) evidence of heat damage.
- (g) excessive pitting or corrosion.
- (h) lack of ability of chain or fittings to hinge (articulate) freely.
- (i) weld splatter.
- (j) for hooks, removal criteria as stated in ASME B30.10.
- (k) for rigging hardware, removal criteria as stated in ASME B30.26.
- (l) other conditions, including visible damage, that cause doubt as to the continued use of the sling.

**9-1.9.6 Repair**

(a) Slings shall be repaired only by the sling manufacturer or a qualified person.

(b) A repaired sling shall be marked to identify the repairing entity per Section 9-1.7.



**1.9.5-1 Minimum Allowable Thickness at Any Point on a Link**

Nominal Chain or Coupling Link Size		Minimum Allowable Thickness at Any Point on the Link	
in.	mm	in.	mm
7/32	5.5	0.189	4.80
9/32	7	0.239	6.07
5/16	8	0.273	6.93
3/8	10	0.342	8.69
1/2	13	0.443	11.26
5/8	16	0.546	13.87
3/4	20	0.687	17.45
7/8	22	0.750	19.05
1	26	0.887	22.53
1 1/4	32	1.091	27.71

(c) Components used for sling repair shall comply with the provisions of this Chapter.

(d) Repair of hooks shall be as specified in ASME B30.10. Repair of below-the-hook lifting devices shall be as specified in ASME B30.20. Repair of all other components shall be as specified by the sling manufacturer, component manufacturer, or a qualified person.

(e) Cracked, broken, stretched, bent, or twisted chain links shall not be repaired; they shall be replaced.

(f) Mechanical coupling links shall not be used within the body of an alloy chain sling to connect two pieces of chain.

(g) Modifications or alterations to a sling shall conform to all repair provisions of this Chapter.

(h) All repairs shall comply with the proof test requirements of Section 9-1.6.

**SECTION 9-1.10: OPERATING PRACTICES**

**9-1.10.1 Sling Selection**

(a) Slings that appear to be damaged shall not be used unless inspected and accepted as usable under Section 9-1.9.

(b) Slings having suitable characteristics for the type of load, hitch, and environment shall be selected in accordance with the requirements of Sections 9-1.5 and 9-1.8.

(c) The rated load of the sling shall not be exceeded. When using a multiple-leg sling, no leg shall be loaded beyond its single-leg rating.

(d) When the choker hitch rating is not identified on the sling, the choker hitch rating shall be 80% of the sling's straight-line hitch rating, unless other ratings are provided by the sling manufacturer or a qualified person.

(e) Rated loads for angles of choke less than 120 deg shall be determined by the sling manufacturer or a qualified person [see Figure 9-1.0-1, illustration (e)].

(f) The rated load of a basket hitch shall be decreased when  $D/d$  ratios smaller than 6 are used. See Table 9-1.10.1-1, or consult the sling manufacturer or a qualified person.

(g) For multiple-leg slings used with nonsymmetrical loads, an analysis by a qualified person should be performed to prevent overloading of any leg.

(h) Multiple-leg slings shall be selected according to the sling's rated load based on the specific angles as stated on the sling's identification. The rated load for use at other angles shall be provided by the sling manufacturer or a qualified person.

(i) Slings shall not be used at an angle of loading less than 30 deg except as recommended by the sling manufacturer or a qualified person.

(j) When a sling leg is used as a basket hitch with the lower connector (hook) attaching to the master link (upper connector), the basket hitch rating shall be limited to its single-leg rating, unless the master link is rated to accommodate that configuration.

(k) Fittings shall be of a shape and size to ensure that they are properly seated in the hook, shackle, or load-handling device.

**9-1.10.2 Cautions to Personnel**

(a) All portions of the human body shall be kept from between the sling and the load, and from between the sling and the hook, shackle, or other load-handling device.

(b) Personnel should not stand in line with or next to the leg(s) of a sling that is under tension.

(c) Personnel shall not stand or pass under a suspended load.

(d) Personnel shall not ride the sling.

**9-1.10.3 Effects of Environment**

Slings should be stored in an area where they will not be subjected to mechanical damage, corrosive action, moisture, extreme temperatures, or kinking (see Section 9-1.8).

**9-1.10.4 Rigging Practices**

(a) Slings shall be shortened or adjusted only by methods approved by the sling manufacturer or a qualified person.

(b) Slings shall not be shortened or lengthened by knotting or twisting.

(c) The sling shall be hitched in a manner to provide control of the load.

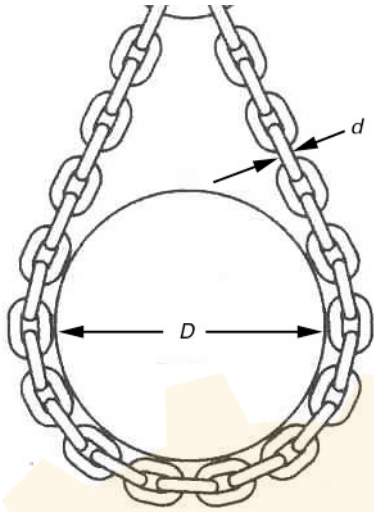
(d) Slings in contact with edges, corners, or protrusions should be protected with a material of sufficient strength, thickness, and construction to prevent damage to the sling.

(e) Shock loading should be avoided.

(f) Loads should not be rested on the sling.

(g) Slings should not be pulled from under a load when the load is resting on the sling.

**D.1-1 Basket Sling Hitch-Rated Capacity Affected by  $D/d$**



- (h) Twisting and kinking shall be avoided.
- (i) During load-handling activities, with or without load, personnel shall be alert for possible snagging.
- (j) When using multiple basket or choker hitches, the load should be rigged to prevent the sling from slipping or sliding along the load.
- (k) When lifting with a basket hitch, the legs of the sling should contain or support the load from the sides, above the center of gravity, so that the load remains under control.
- (l) Slings should not be dragged on the floor or over an abrasive surface.
- (m) In a choker hitch, the choke point should only be on the sling body, never on a fitting.
- (n) Slings should not be constricted, bunched, or pinched by the load, hook, or any fitting.
- (o) The load applied to the hook should be centered in the base (bowl) of the hook to prevent point loading on the hook, unless the hook is designed for point loading.

$D/d$	Rated Capacity, %
Less than 2	Not recommended
2	60
3	70
4	80
5	90
6 and above	100

## Chapter 9-2

# Wire Rope Slings: Selection, Use, and Maintenance

### SECTION 9-2.0: SCOPE

Chapter 9-2 includes provisions that apply to wire rope slings. (See Figures 9-2.0-1 and 9-2.0-2.)

NOTE: Boom pendants are not within the scope of this Chapter.

### SECTION 9-2.1: TRAINING

Wire rope sling users shall be trained in the selection, inspection, cautions to personnel, effects of environment, and rigging practices as covered in this Chapter.

### SECTION 9-2.2: COMPONENTS

#### 9-2.2.1 Wire Rope

The wire rope shall be manufactured and tested in accordance with ASTM A1023/A1023M and ASTM A586.

(a) Only new or unused wire rope shall be used for fabricating slings covered in this Chapter.

(b) Only regular-lay wire rope shall be used for fabricating slings covered in this Chapter.

(c) Rotation-resistant wire rope shall not be used for fabricating slings covered in this Chapter.

#### (18) 9-2.2.2 Fittings

(a) Fittings such as sleeves and sockets shall be used in accordance with the component manufacturer's recommendations.

(b) When employed, hooks shall meet the requirements of ASME B30.10.

(c) Welding of handles or any other accessories to end attachments, except covers to thimbles, shall be performed prior to the assembly of the sling.

(d) When employed, rigging hardware shall meet the requirements of ASME B30.26.

(e) Fitting surfaces in contact with the sling shall be finished to remove edges that could damage the sling.

#### 9-2.2.3 Other Components

(18)

Slings that employ wire ropes and fittings, other than those listed in paras. 9-2.2.1 and 9-2.2.2, may be used. When such components are employed, the sling manufacturer or a qualified person shall provide specific data regarding deviations from the applicable section of this Chapter. These slings shall comply with all other requirements of this Chapter.

### SECTION 9-2.3: FABRICATION AND CONFIGURATIONS

#### 9-2.3.1 Fabrication

(18)

Methods of fabrication include hand-tucked splicing, turnback eye (return loop), or flemish eye mechanical splicing, and poured or swaged socketing. Mechanical wire rope terminations requiring periodic adjustment to maintain efficiency shall not be used to fabricate slings.

(a) Knots shall not be used to fabricate slings.

(b) Other fabrication methods not covered by this Chapter shall be rated in accordance with the recommendation of the sling manufacturer or a qualified person, and shall conform to all other provisions of this Chapter.

Figure 9-2.0-1 Wire Rope Sling

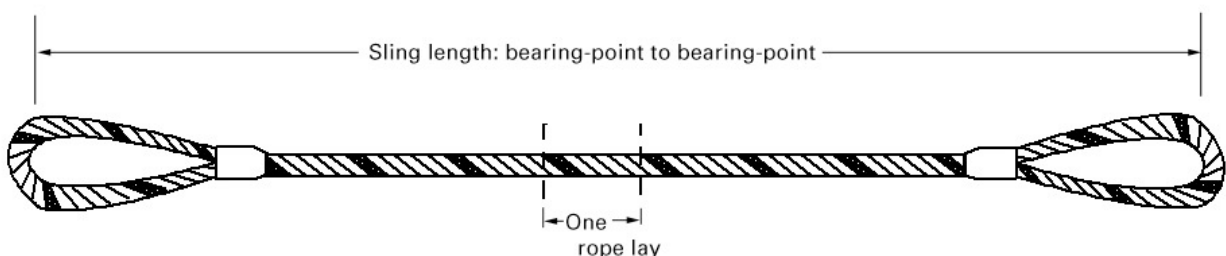
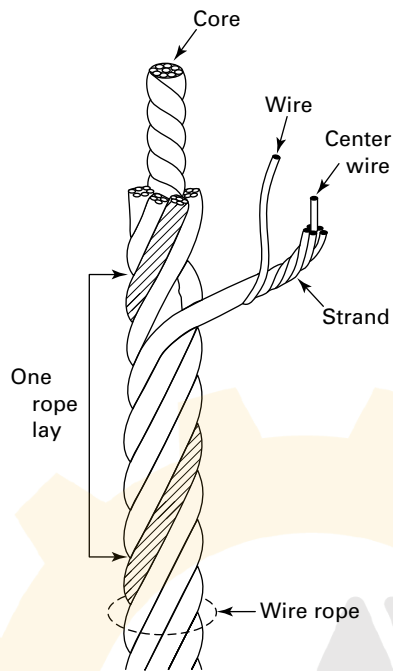


Figure 9-2.0-2 Wire Rope



### 9-2.3.2 Configurations

(a) Single-leg slings and two-leg, three-leg, and four-leg bridle slings used in straight-line, choker, and basket hitches are covered by this Chapter.

NOTE: A straight-line hitch is commonly referred to as a vertical hitch.

(b) Slings made of rope with  $6 \times 19$  and  $6 \times 36$  classification and cable-laid slings shall have a minimum clear length of rope 10 times the rope diameter between splices, sleeves, or end fittings (see Figure 9-2.3.2-1), unless approved by the manufacturer or a qualified person.

(c) Braided slings shall have a minimum clear length of rope 40 times the component rope diameter between the loops or end fittings (see Figure 9-2.3.2-2), unless approved by the manufacturer or a qualified person.

(d) Grommets and endless slings shall have a minimum circumferential length of 96 times the body diameter of the grommet or endless sling unless approved by the manufacturer or a qualified person.

(e) Other configurations may be used. When used, the sling manufacturer or a qualified person shall provide specific data. These slings shall comply with all other requirements of this Chapter.

### SECTION 9-2.4: DESIGN FACTOR

The design factor for wire rope slings shall be a minimum of 5.

### SECTION 9-2.5: RATED LOAD

(a) The sling manufacturer shall establish the sling's rated load.

(b) At a minimum, the rated load shall be based on the following factors:

- (1) component strength
- (2) number of legs
- (3) design factor
- (4) type of hitch
- (5) angle of loading (see Figure 9-2.5-1)
- (6) fabrication efficiency

### SECTION 9-2.6: PROOF TEST REQUIREMENTS

#### 9-2.6.1 General

(a) Prior to initial use, all new swaged socket, poured socket, or turnback swaged eye type slings, and mechanical joint endless wire rope slings shall be proof tested by the sling manufacturer or a qualified person.

(b) Prior to initial use, all wire rope slings incorporating previously used or welded fittings and all repaired slings shall be proof tested by the sling manufacturer or a qualified person.

(c) All other new wire rope slings are not required to be proof tested unless specified by the purchaser.

#### 9-2.6.2 Proof Load Requirements

(a) For single- or multiple-leg slings and endless slings, each leg shall be proof loaded to the following load requirements based on fabrication method.

(1) *Mechanical Splice Slings.* The proof load shall be a minimum of 2 times and a maximum of 2.5 times the single-leg straight-line hitch rated load.

(2) *Swaged Socket and Poured Socket Slings.* The proof load shall be a minimum of 2 times and a maximum of 2.5 times the single-leg straight-line hitch rated load.

(3) *Hand-Tucked Slings.* If proof tested, the proof load shall be a minimum of 1 times and a maximum of 1.25 times the single-leg straight-line hitch rated load.

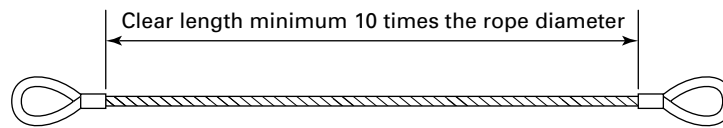
(b) The proof load for components (fittings) attached to single legs shall be the same as the requirement for single-leg slings in (a).

(c) Master links for two-leg bridle slings shall be proof loaded to a minimum of 4 times the single-leg straight-line hitch rated load.

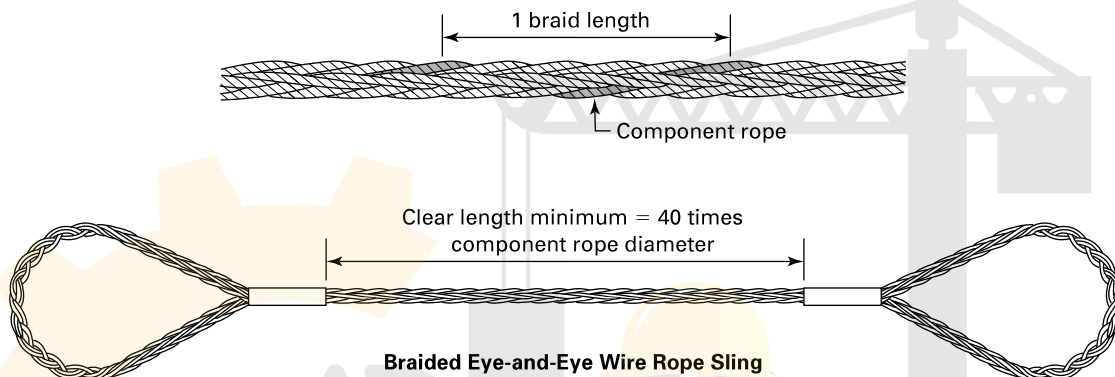
(d) Master links for three-leg bridle slings shall be proof loaded to a minimum of 6 times the single-leg straight-line hitch rated load.

(e) Master links for four-leg bridle slings shall be proof loaded to a minimum of 8 times the single-leg straight-line hitch rated load.

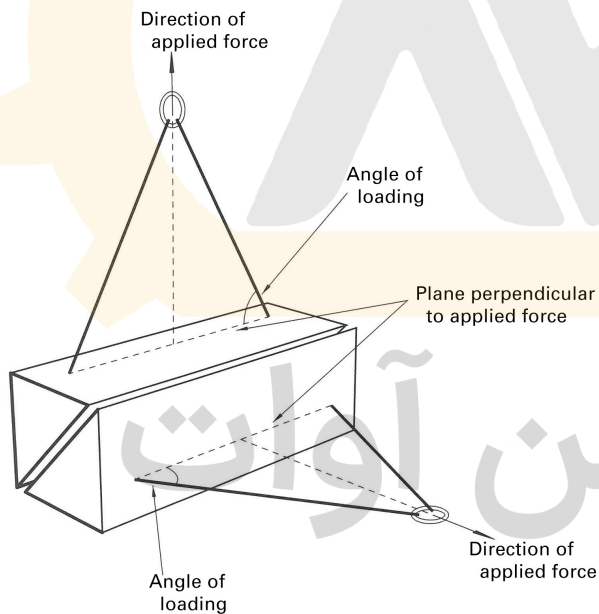
**Figure 9-2.3.2-1 Minimum Sling Length**



**Figure 9-2.3.2-2 Minimum Braided Sling Length**



**Figure 9-2.5-1 Angle of Loading**



## SECTION 9-2.7: SLING IDENTIFICATION

### 9-2.7.1 Identification Requirements

Each sling shall be marked to show

- (a) name or trademark of manufacturer, or if repaired, the entity performing repairs
- (b) rated load for at least one hitch type and the angle upon which it is based
- (c) diameter or size

(d) number of legs, if more than one

### 9-2.7.2 Initial Sling Identification

Sling identification shall be done by the sling manufacturer.

### 9-2.7.3 Maintenance of Sling Identification

Sling identification should be maintained by the user so as to be legible during the life of the sling.

### 9-2.7.4 Replacement of Sling Identification

Replacement of the sling identification shall be considered a repair as specified in [paras. 9-2.9.6\(a\)](#) and [9-2.9.6\(b\)](#). Additional proof testing is not required.

## SECTION 9-2.8: EFFECTS OF ENVIRONMENT

### 9-2.8.1 Temperature

(a) Fiber core wire rope slings of all grades shall not be exposed to temperatures in excess of 180°F (82°C).

(b) When fiber core wire rope slings are to be used at temperatures below -40°F (-40°C), the sling manufacturer should be consulted.

(c) When IWRC wire rope slings are to be used at temperatures above 400°F (204°C) or below -40°F (-40°C), the sling manufacturer should be consulted.

### 9-2.8.2 Chemically Active Environments

The strength of wire rope slings may be degraded by chemically active environments. This includes exposure to chemicals in the form of solids, liquids, gases, vapors, or



ing manufacturer or a qualified person consulted before slings are used in chemically environments.

## SECTION 9-2.9: INSPECTION, REMOVAL, AND REPAIR

### (18) 9-2.9.1 General

All inspections shall be performed by a designated person. Any deficiency identified shall be examined and a determination made by a qualified person as to whether it constitutes a hazard, and if so, what additional steps need to be taken to address the hazard.

### 9-2.9.2 Initial Inspection

Prior to use, all new, altered, modified, or repaired slings shall be inspected to verify compliance with the applicable provisions of this Chapter. Written records are not required for initial inspections.

### (18) 9-2.9.3 Frequent Inspection

(a) Each shift, before the sling is used, a visual inspection for damage shall be performed. Slings used in severe or special service should be inspected before each use.

(b) Slings found with conditions such as those listed in [para. 9-2.9.5](#) shall be removed from service. Slings shall not be returned to service until approved by a qualified person.

(c) Written records are not required for frequent inspections.

### (18) 9-2.9.4 Periodic Inspection

(a) A complete inspection of the sling shall be performed. Inspection shall be conducted on the entire length, including splices and fittings. Slings found with conditions such as those listed in [para. 9-2.9.5](#) shall be removed from service. Slings shall not be returned to service until approved by a qualified person.

(b) *Periodic Inspection Frequency.* Periodic inspection intervals shall not exceed 1 yr [see (d)]. The frequency of periodic inspections should be based on

- (1) frequency of sling use
- (2) severity of service conditions
- (3) nature of load-handling activities
- (4) experience gained on the service life of slings used in similar circumstances

(c) Guidelines for the time intervals are

- (1) normal service — yearly
- (2) severe service — monthly to quarterly
- (3) special service — as recommended by a qualified person

(d) Periodic inspection is not required for a sling that is in storage or idle. However, if more than 1 yr has passed since the last periodic inspection, the sling shall be

inspected in accordance with the requirements listed in (a) and (e) before being placed back into service."

(e) Documentation that the most recent periodic inspection was performed shall be maintained.

(f) Inspection records of individual slings are not required.

### 9-2.9.5 Removal Criteria

A wire rope sling shall be removed from service if any of the following conditions are present:

(a) missing or illegible sling identification (see [Section 9-2.7](#))

(b) broken wires

(1) for strand-laid and single-part slings, 10 randomly distributed broken wires in one rope lay, or 5 broken wires in one strand in one rope lay (see [Figure 9-2.0-2](#))

(2) for cable-laid slings, 20 broken wires per lay (see [Figure 9-2.9.5-1](#))

(3) for less than eight-part braided slings, 20 broken wires per braid length (see [Figure 9-2.3.2-2](#))

(4) for eight-part or more than eight-part braided slings, 40 broken wires per braid length (see [Figure 9-2.3.2-2](#))

(c) severe localized abrasion or scraping resulting in a reduction from nominal diameter of more than 5%

(d) kinking, crushing, birdcaging, or any other damage resulting in damage to the rope structure

(e) evidence of heat damage

(f) fittings that are cracked, deformed, or worn to the extent that the strength of the sling is substantially affected

(g) severe corrosion of the rope or fittings

(h) for hooks, removal criteria as stated in ASME B30.10

(i) for rigging hardware, removal criteria as stated in ASME B30.26

(j) other conditions, including visible damage, that cause doubt as to the continued use of the sling

### 9-2.9.6 Repair

(a) Slings shall be repaired only by the sling manufacturer or a qualified person.

(b) A repaired sling shall be marked to identify the repairing entity per [Section 9-2.7](#).

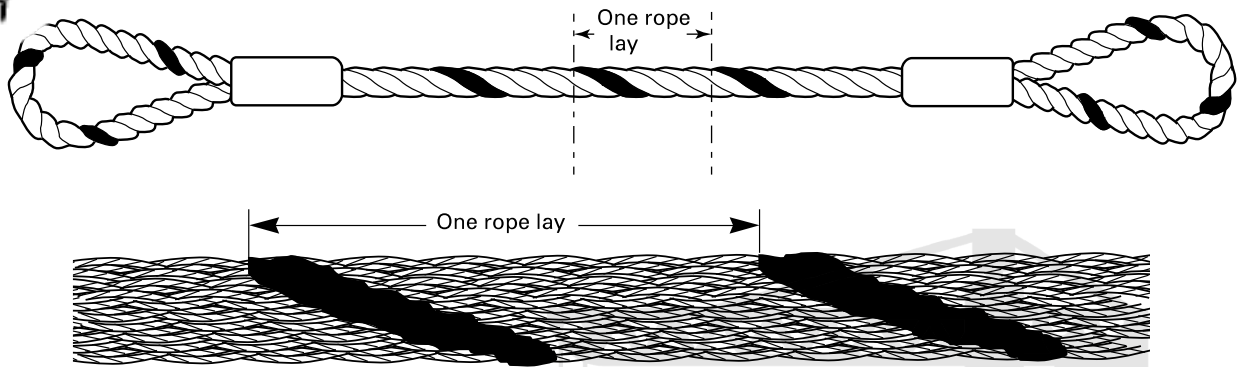
(c) Components used for sling repair shall comply with the provisions of this Chapter.

(d) Repair of hooks shall be as specified in ASME B30.10. Repair of below-the hook lifting devices shall be as specified in ASME B30.20. Repair of all other components shall be as specified by the sling manufacturer, component manufacturer, or a qualified person.

(e) The wire rope used in the sling shall not be repaired.

(f) Modifications or alterations to a sling shall conform to all repair provisions of this Chapter.

Figure 9-2.9.5-1 Cable-Laid Wire Rope Sling



(g) All repairs shall comply with the proof test requirements of [Section 9-2.6](#).

## SECTION 9-2.10: OPERATING PRACTICES

### 9-2.10.1 Sling Selection

(a) Slings that appear to be damaged shall not be used unless inspected and accepted as usable under [Section 9-2.9](#).

(b) Slings having suitable characteristics for the type of load, hitch, and environment shall be selected in accordance with the requirements of [Sections 9-2.5](#) and [9-2.8](#).

(c) The rated load of the sling shall not be exceeded. When using a multiple-leg sling, no leg shall be loaded beyond its single-leg rating.

(d) When the choker hitch rating is not identified on the sling, the choker hitch rating for single-leg and bridle slings shall be 75% of the sling's straight-line hitch rating (70% for cable-laid slings), unless other ratings are provided by the sling manufacturer or a qualified person. Consult the sling manufacturer or a qualified person for choker hitch ratings for grommets and endless slings.

(e) Rated loads for angles of choke less than 120 deg shall be determined by using the values in [Table 9-2.10.1-1](#), or by consulting the sling manufacturer or a qualified person.

(f) For multiple-leg slings used with nonsymmetrical loads, an analysis by a qualified person should be performed to prevent overloading of any leg.

(g) Multiple-leg slings shall be selected according to the sling's rated load based on the specific angle(s) as stated on the sling's identification. The rated load for use at other angles shall be provided by the sling manufacturer or a qualified person.

(h) When  $D/d$  ratios (see [Figure 9-2.10.1-1](#)) smaller than 15/1 for hand-tucked splice type slings and 25/1 for mechanical splice and swaged or poured socket-type slings are used in the body of the sling, the rated load of the sling shall be decreased according to the recommendations of the manufacturer, a qualified person, or

the Wire Rope Sling Users Manual. For other sling types, consult the sling manufacturer for specific data or refer to the Wire Rope Sling Users Manual.

(i) Slings shall not be used at an angle of loading less than 30 deg except as recommended by the sling manufacturer or a qualified person.

(j) When a sling leg is used as a basket hitch with the lower connector (hook) attaching to the master link (upper connector), the basket hitch rating shall be limited to its single-leg rating, unless the master link is rated to accommodate that configuration.

(k) Fittings shall be of a shape and size to ensure that they are properly seated in the hook, shackle, or other load-handling device.

### 9-2.10.2 Cautions to Personnel

(a) All portions of the human body shall be kept from between the sling and load, and from between the sling and hook, shackle, or other load-handling device.

(b) Personnel should not stand in line with or next to the leg(s) of a sling that is under tension.

(c) Personnel shall not stand or pass under a suspended load.

(d) Personnel shall not ride the sling.

(e) Do not inspect a sling by passing bare hands over the wire rope body. Broken wires, if present, may puncture the hands.

### 9-2.10.3 Effects of Environment

(a) Slings should be stored in an area where they will not be subjected to mechanical damage, corrosive action, moisture, extreme temperatures, or kinking (see [Section 9-2.8](#)).

(b) Fiber core wire rope slings should not be subjected to degreasing or a solvent because of possible damage to the core.



0.1-1 Angle of Choke: Wire Rope Slings

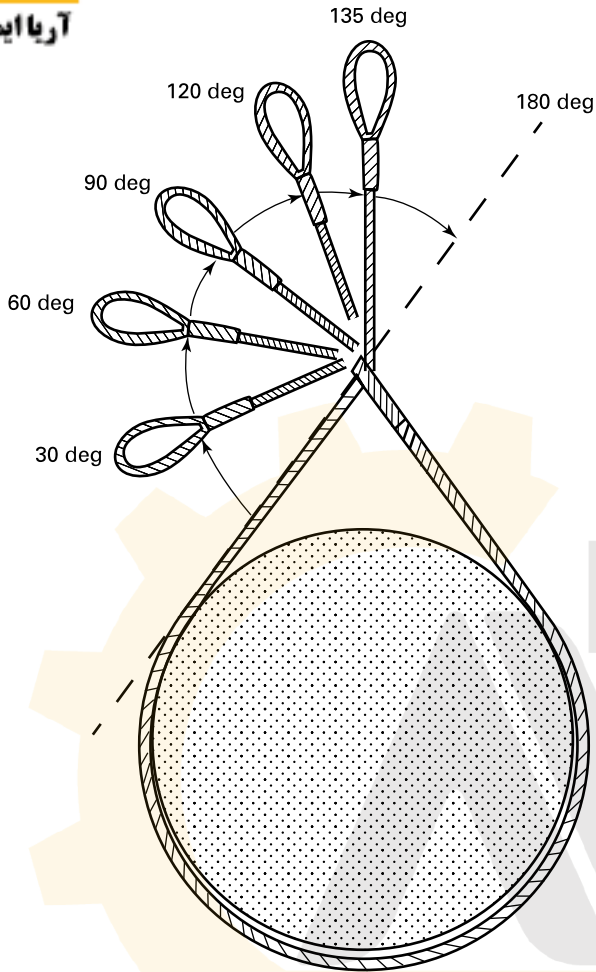
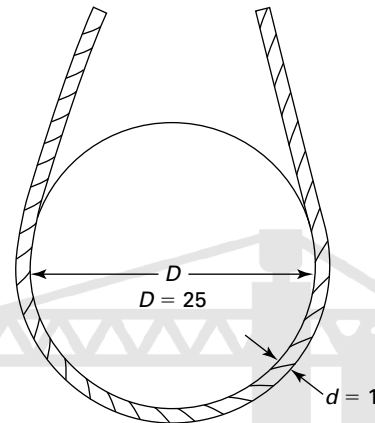


Figure 9-2.10.1-1  $D/d$  Ratio: Wire Rope Slings



GENERAL NOTE: When  $D$  is 25 times the component rope diameter,  $d$ , the  $D/d$  ratio is expressed as 25/1.

Angle of Choke, deg	Rated Capacity, % [Note (1)]
Over 120	100
90-120	87
60-89	74
30-59	62
0-29	49

NOTE: (1) Percent of sling rated capacity in a choker hitch.

9-2.10.4 Rigging Practices

(18)

- (a) Slings shall be shortened or adjusted only by methods approved by the sling manufacturer or a qualified person.
- (b) Slings shall not be shortened or lengthened by knotting or twisting, or by wire rope clips.
- (c) The sling shall be hitched in a manner providing control of the load.
- (d) Slings in contact with edges, corners, or protrusions should be protected with a material of sufficient strength, thickness, and construction to prevent damage to the sling.
- (e) Shock loading should be avoided.
- (f) Loads should not be rested on the sling.
- (g) Slings should not be pulled from under a load when the load is resting on the sling.
- (h) Twisting and kinking shall be avoided.
- (i) During load-handling activities, with or without load, personnel shall be alert for possible snagging.
- (j) When using multiple basket or choker hitches, the load should be rigged to prevent the sling from slipping or sliding along the load.
- (k) When lifting with a basket hitch, the legs of the sling should contain or support the load from the sides, above the center of gravity, so that the load remains under control.
- (l) Slings should not be dragged on the floor or over an abrasive surface.
- (m) In a choker hitch, the choke point should only be on the sling body, not on a splice or fitting.

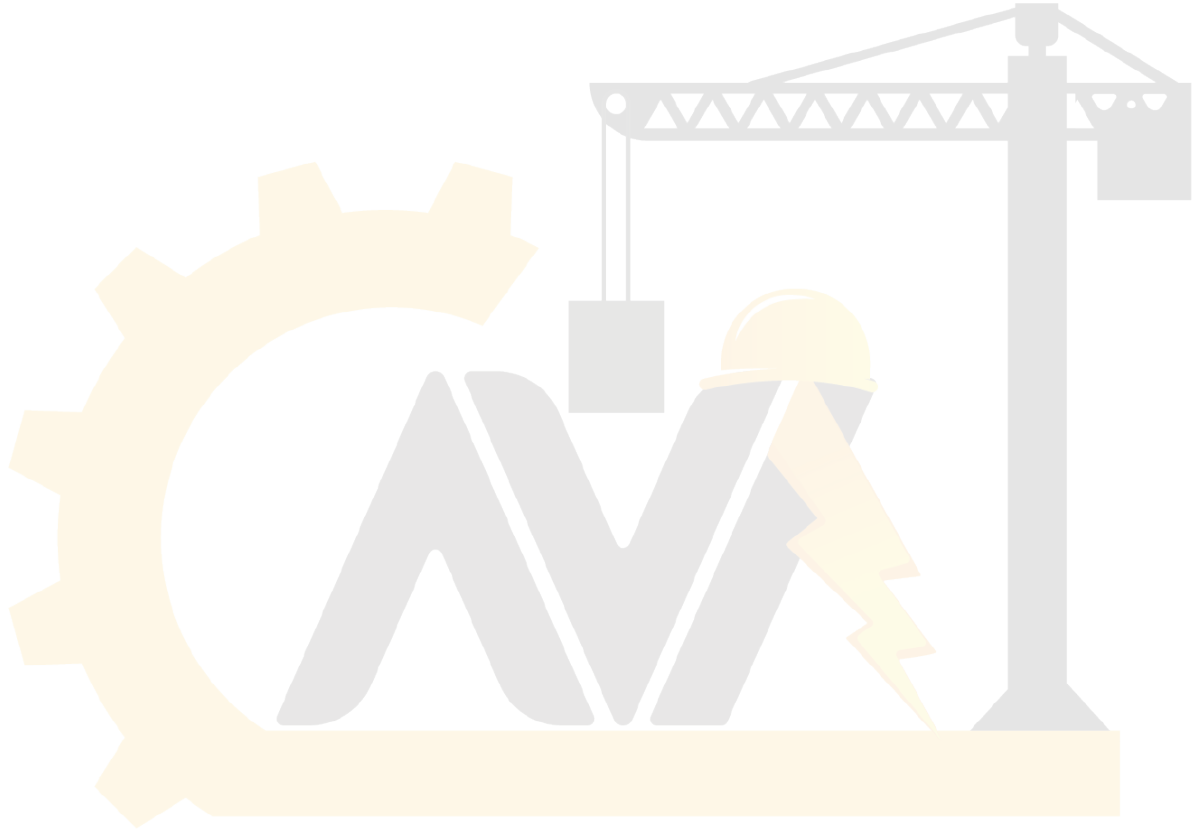


ings should not be constricted, bunched, or by the load, hook, or any fitting.

The load applied to the hook should be centered in the base (bowl) of the hook to prevent point loading on the hook, unless the hook is designed for point loading.

(p) An object in the eye of a sling should not be wider than one half the length of the eye nor less than the nominal sling diameter.

(q) When a hand-tucked sling is used, the sling, load, or load-handling device shall be prevented from rotating.



# آریا ایمن آوات

## Chapter 9-3

# Metal Mesh Slings: Selection, Use, and Maintenance

### SECTION 9-3.0: SCOPE

Chapter 9-3 includes provisions that apply to metal mesh slings (see Figure 9-3.0-1).

### SECTION 9-3.1: TRAINING

Metal mesh sling users shall be trained in the selection, inspection, cautions to personnel, effects of environment, and rigging practices as covered by this Chapter.

### SECTION 9-3.2: COMPONENTS

#### 9-3.2.1 Metal Mesh

The metal mesh shall be carbon steel and manufactured in accordance with the specifications in Table 9-3.2.1-1.

#### (18) 9-3.2.2 Fittings

(a) Fittings shall have sufficient strength to sustain 2 times the rated load of the sling without visible permanent deformation.

(b) Fitting surfaces in contact with the sling shall be finished to remove edges that could damage the sling.

#### (18) 9-3.2.3 Other Components

Slings that employ metal mesh and fittings other than those listed in paras. 9-3.2.1 and 9-3.2.2 may be used. When such materials are employed, the sling manufacturer or a qualified person shall provide specific data regarding deviations from the applicable sections of this Chapter. These slings shall comply with all other requirements of this Chapter.

### SECTION 9-3.3: FABRICATION AND CONFIGURATIONS

#### 9-3.3.1 Fabrication

Methods of fabrication include welding or brazing.

#### 9-3.3.2 Coatings

Finishes and coatings shall be compatible with the sling components and not impair the performance of the sling.

#### 9-3.3.3 Configurations

Single-leg slings used in straight-line, choker, and basket hitches are covered in this Chapter.

NOTE: A straight-line hitch is commonly referred to as a vertical hitch.

#### SECTION 9-3.4: DESIGN FACTOR

The design factor for metal mesh slings shall be a minimum of 5.

#### SECTION 9-3.5: RATED LOAD

(a) The sling manufacturer shall establish the sling's rated load.

(b) At a minimum, the rated load shall be based on the following factors:

- (1) component strength
- (2) design factor
- (3) type of hitch
- (4) angle of loading (see Figure 9-3.5-1)

#### SECTION 9-3.6: PROOF TEST REQUIREMENTS

##### 9-3.6.1 General

(a) Prior to initial use, all new and repaired metal mesh slings shall be proof tested by the sling manufacturer or a qualified person.

(b) Coated slings should be proof tested prior to coating.

##### 9-3.6.2 Proof Load Requirements

The proof load shall be a minimum of 2 times the straight-line hitch rated load.

#### SECTION 9-3.7: SLING IDENTIFICATION

##### 9-3.7.1 Identification Requirements

Each sling shall be marked to show

(a) name or trademark of manufacturer, or if repaired, the entity performing repairs

(b) rated load for at least one hitch type and the angle upon which it is based

(c) individual sling identification (e.g., serial number)

Figure 9-3.0-1 Metal Mesh Sling

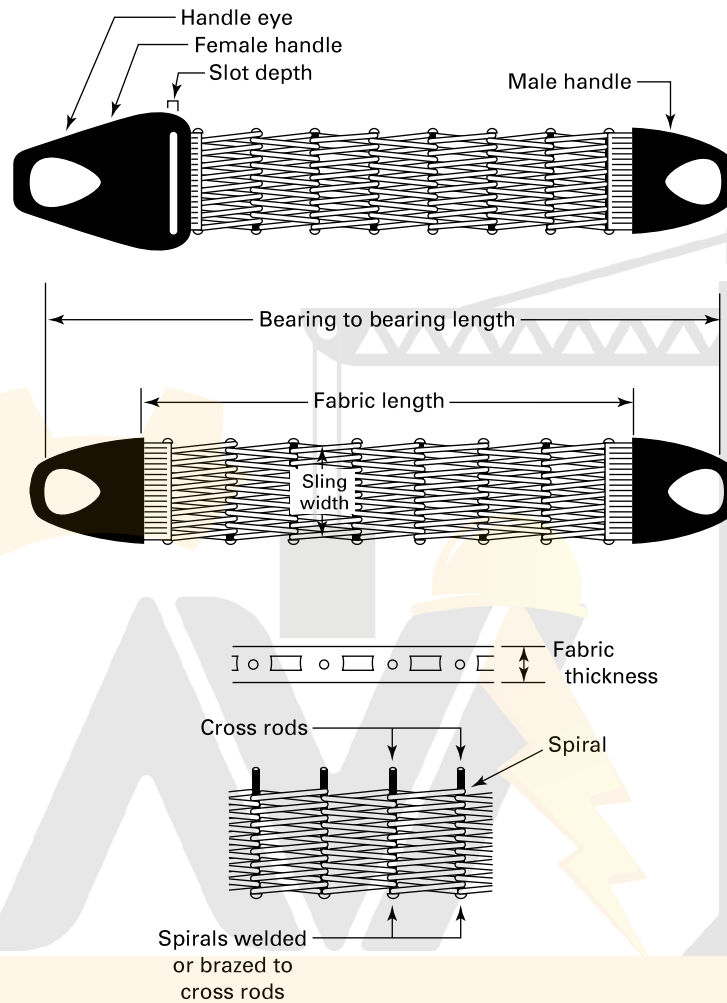


Table 9-3.2.1-1 Fabric Construction: Metal Mesh Slings

Specification	Heavy Duty	Medium Duty	Light Duty
Nominal spiral turns per foot mesh width	35	43	59
Approx. spiral wire size	10 gage	12 gage	14 gage
Equivalent decimal size	0.135 in.	0.105 in.	0.080 in.
Nominal cross rods per foot of fabric length	21	30	38
Approximate size of cross rods	8 gage	10 gage	14 gage
Equivalent decimal size	0.162 in.	0.135 in.	0.080 in.
Nominal fabric thickness	1/2 in.	3/8 in.	5/16 in.

### 9-3.7.2 Initial Sling Identification

Sling identification shall be done by the sling manufacturer.

### 9-3.7.3 Maintenance of Sling Identification

Sling identification should be maintained by the user so as to be legible during the life of the sling.

### 9-3.7.4 Replacement of Sling Identification

Replacement of the sling identification shall be considered a repair as specified in [paras. 9-3.9.6\(a\)](#) and [9-3.9.6\(b\)](#). Additional proof testing is not required.

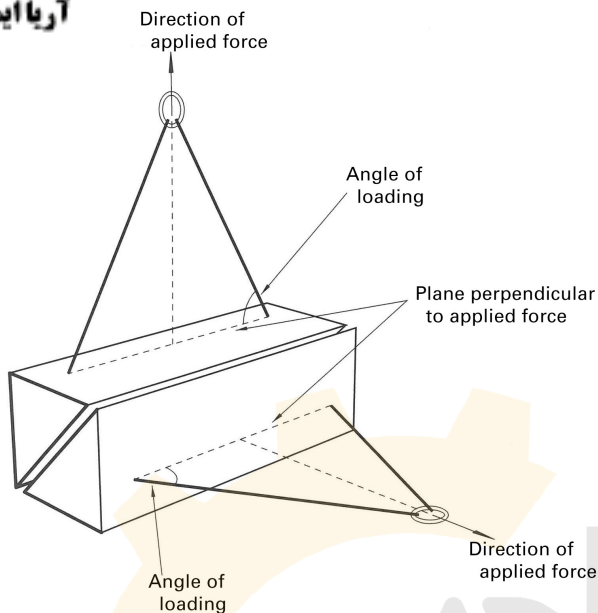
## SECTION 9-3.8: EFFECTS OF ENVIRONMENT

### 9-3.8.1 Temperature

(a) When slings are used at temperatures above 550°F (228°C) or below -20°F (-29°C), the sling manufacturer should be consulted.

(b) If the sling contains any coatings that change the temperature range of the sling, the sling manufacturer shall provide the revised temperature range.

Figure 9-3.5-1 Angle of Loading



### 9-3.8.2 Chemically Active Environments

The strength of metal mesh slings may be degraded by chemically active environments. This includes exposure to chemicals in the form of solids, liquids, gases, vapors, or fumes. The sling manufacturer or a qualified person should be consulted before slings are used in chemically active environments.

## SECTION 9-3.9: INSPECTION, REMOVAL, AND REPAIR

### (18) 9-3.9.1 General

All inspections shall be performed by a designated person. Any deficiency identified shall be examined and a determination made by a qualified person as to whether it constitutes a hazard, and if so, what additional steps need to be taken to address the hazard.

### 9-3.9.2 Initial Inspection

Prior to use, each new, altered, modified, or repaired sling shall be inspected to verify compliance with the applicable provisions of this Chapter. A written record of the inspection referencing the individual sling identification is required.

### (18) 9-3.9.3 Frequent Inspection

(a) Each shift, before the sling is used, a visual inspection for damage shall be performed. Slings used in severe or special service should be inspected before each use.

(b) Slings found with conditions such as those listed in para. 9-3.9.5 shall be removed from service. Slings shall not be returned to service until approved by a qualified person.

(c) Written records are not required for frequent inspections.

### 9-3.9.4 Periodic Inspection

(18)

(a) A complete inspection for damage to the sling shall be performed. Inspection shall be conducted on the entire length, including welded or brazed joints and fittings. Slings found with conditions such as those listed in para. 9-3.9.5 shall be removed from service. Slings shall not be returned to service until approved by a qualified person.

(b) *Periodic Inspection Frequency.* Periodic inspection intervals shall not exceed 1 yr [see (d)]. The frequency of periodic inspections should be based on

- (1) frequency of sling use
- (2) severity of service conditions
- (3) nature of load-handling activities
- (4) experience gained on the service life of slings used in similar circumstances

(c) Guidelines for the time intervals are

- (1) normal service — yearly
- (2) severe service — monthly to quarterly
- (3) special service — as recommended by a qualified person

(d) Periodic inspection is not required for a sling that is in storage or idle. However, if more than 1 yr has passed since the last periodic inspection, the sling shall be inspected in accordance with the requirements listed in (a) and (e) before being placed back into service.

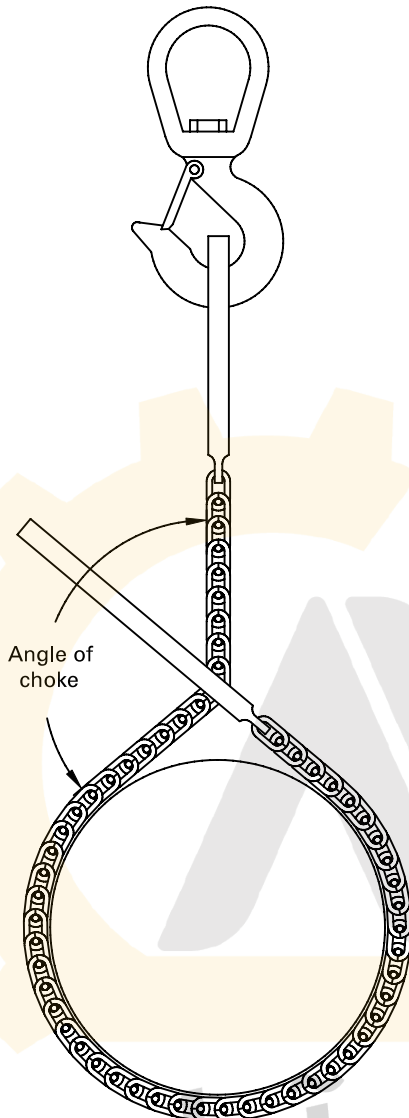
(e) A written record of the most recent periodic inspection shall be maintained and shall include the condition of the sling.

### 9-3.9.5 Removal Criteria

A metal mesh sling shall be removed from service if any of the following conditions are present:

- (a) missing or illegible sling identification (see Section 9-3.7)
- (b) broken weld or a broken brazed joint along the sling edge
- (c) broken wire in any part of the mesh
- (d) reduction in wire diameter of 25% due to abrasion or 15% due to corrosion
- (e) lack of flexibility due to distortion of the mesh
- (f) distortion of the choker fitting so the depth of the slot is increased by more than 10%
- (g) distortion of either end fitting so the width of the eye opening is decreased by more than 10%
- (h) a 15% reduction of the original cross-sectional area of any point around the hook opening of the end fitting
- (i) visible distortion of either end fitting out of its plane

### -3.10.1-1 Angle of Choke: Metal Mesh Slings



- (j) cracked end fitting
- (k) slings in which the spirals are locked or without free articulation shall not be used
- (l) fittings that are pitted, corroded, cracked, bent, twisted, gouged, or broken
- (m) other conditions, including visible damage, that cause doubt as to the continued use of the sling

#### 9-3.9.6 Repair

- (a) Slings shall be repaired only by the sling manufacturer or a qualified person.
- (b) A repaired sling shall be marked to identify the repairing entity per [Section 9-3.7](#).
- (c) Components used for sling repair shall comply with the provisions of this Chapter.

(d) Cracked, broken, bent, or damaged components shall not be repaired; they shall be replaced.

(e) All repairs shall comply with the proof test requirements of [Section 9-3.6](#).

(f) Modifications or alterations to a sling shall conform to all repair provisions of this Chapter.

## SECTION 9-3.10: OPERATING PRACTICES

### 9-3.10.1 Sling Selection

(a) Slings that appear to be damaged shall not be used unless inspected and accepted as usable under [Section 9-3.9](#).

(b) Slings having suitable characteristics for the type of load, hitch, and environment shall be selected in accordance with the requirements of [Sections 9-3.5](#) and [9-3.8](#).

(c) The rated load of the sling shall not be exceeded.

(d) When the choker hitch rating is not identified on the sling, the choker hitch rating shall be 100% of the sling's straight-line hitch rating, unless other ratings are provided by the sling manufacturer or a qualified person.

(e) Rated loads for angles of choke less than 120 deg shall be determined by the sling manufacturer or a qualified person (see [Figure 9-3.10.1-1](#)).

(f) Slings shall not be used at an angle of loading less than 30 deg except as recommended by the sling manufacturer or a qualified person (see [Figure 9-3.5-1](#)).

(g) Fittings shall be of a shape and size to ensure that they are properly seated in the hook, shackle, or other load-handling device.

(h) Metal mesh slings shall not be used as bridles on suspended personnel platforms.

### 9-3.10.2 Cautions to Personnel

(a) All portions of the human body shall be kept from between the sling and the load, and from between the sling and the hook, shackle, or other load-handling device.

(b) Personnel should not stand in line with or next to the leg(s) of a sling that is under tension.

(c) Personnel shall not stand or pass under a suspended load.

(d) Personnel shall not ride the sling.

### 9-3.10.3 Effects of Environment

Slings should be stored in an area where they will not be subjected to mechanical damage, corrosive action, moisture, extreme temperatures, or kinking (see [Section 9-3.8](#)).

### 9-3.10.4 Rigging Practices

(a) Slings shall be shortened or adjusted only by methods approved by the sling manufacturer or a qualified person.



d should be evenly distributed across the metal mesh.

e sling shall be hitched in a manner providing control of the load.

(d) Slings in contact with edges, corners, or protrusions should be protected with a material of sufficient strength, thickness, and construction to prevent damage.

(e) Shock loading should be avoided.

(f) Loads should not be rested on the sling.

(g) Slings should not be pulled from under a load when the load is resting on the sling.

(h) Twisting and kinking shall be avoided.

(i) During load-handling activities, with or without load, personnel shall be alert for possible snagging.

(j) In a basket hitch, the load should be balanced to prevent slippage.

(k) When lifting with a basket hitch, the legs of the sling should contain or support the load from the sides, above the center of gravity, so that the load remains under control.

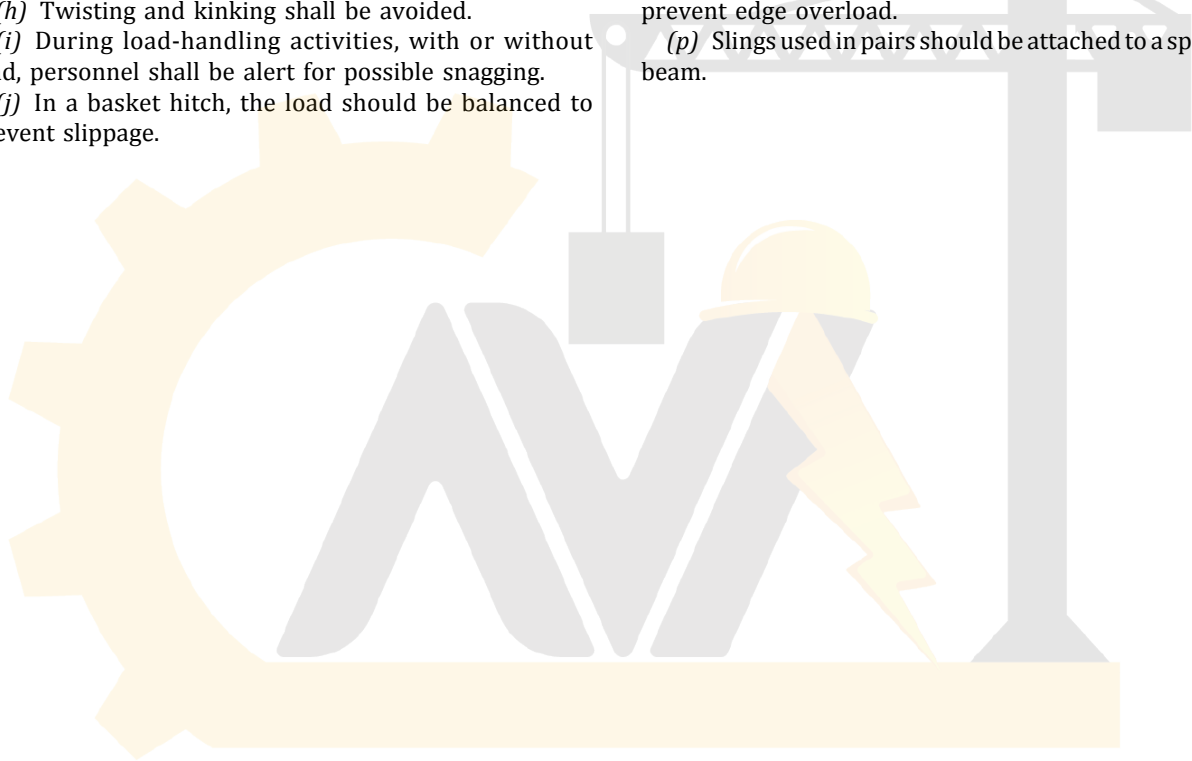
(l) Slings should not be dragged on the floor or over an abrasive surface.

(m) In a choker hitch, the choke point should only be on the sling body, not on a weld, braze, or end fitting.

(n) Slings should not be constricted, bunched, or pinched by the load, hook, or any fitting.

(o) In a choker hitch, the load should be balanced to prevent edge overload.

(p) Slings used in pairs should be attached to a spreader beam.



# آریا ایمن آوات



## Chapter 9-4 Synthetic Rope Slings: Selection, Use, and Maintenance

### SECTION 9-4.0: SCOPE

Chapter 9-4 includes provisions that apply to synthetic rope slings (see Figure 9-4.0-1).

### SECTION 9-4.1: TRAINING

Synthetic rope sling users shall be trained in the selection, inspection, cautions to personnel, effects of environment, and rigging practices as covered by this Chapter.

### SECTION 9-4.2: COMPONENTS

#### 9-4.2.1 Synthetic Ropes

(a) Synthetic fiber materials covered for use in synthetic ropes are nylon and polyester. Rope constructions covered are three-strand laid, eight-strand plaited, single braided, and double braided. The rope constructions shall be manufactured and tested in accordance with one of the following applicable Cordage Institute specifications:

Rope Type	Designation
Nylon three-strand laid	CI 1303
Nylon eight-strand plaited	CI 1303
Nylon double braid	CI 1306
Polyester three-strand laid	CI 1304
Polyester eight-strand plaited	CI 1304
Polyester double braid	CI 1307
Polyester single braid	CI 1305

(b) Synthetic ropes shall be made of fibers that have been produced with an appropriate ultraviolet inhibitor.

#### (18) 9-4.2.2 Fittings

Fittings should be selected to meet the following requirements:

(a) Suitability of mechanical or socketed fittings shall be verified by a qualified person.

(b) The material shall be compatible with the mechanical and environmental requirements imposed on the sling.

(c) Fittings shall have sufficient strength to sustain twice the rated load of the sling without visible permanent deformation.

(d) Fitting surfaces in contact with the sling shall be finished to remove edges that could damage the sling.

(e) Thimbles shall have a minimum diameter at the bearing surface of at least 2 times the rope diameter.

(f) When employed, hooks shall meet the requirements of ASME B30.10.

(g) When employed, rigging hardware shall meet the requirements of ASME B30.26.

#### 9-4.2.3 Other Components

(18)

Slings that employ synthetic ropes and fittings other than those listed in paras. 9-4.2.1 and 9-4.2.2 may be used. When such components are employed, the sling manufacturer or a qualified person shall provide specific data regarding deviations from the applicable sections of this Chapter. These slings shall comply with all other requirements of this Chapter.

### SECTION 9-4.3: FABRICATION AND CONFIGURATIONS

#### 9-4.3.1 Fabrication

Hand splicing is the preferred method of fabricating slings. All splices shall be made in accordance with splicing instructions provided by the rope manufacturer or a qualified person. In addition, the following shall be observed:

(a) When forming an eye in three-strand and eight-strand synthetic ropes, a hand-tucked splice with no less than four full tucks shall be used. When forming an endless sling, a short splice containing at least six full tucks, three on each side of the center of the splice shall be used.

(b) Strand end tails in all tuck splices shall not be trimmed short (cut flush with the body of the rope). In cases where the projecting tails may be objectionable, the tails shall be tapered and buried into the body of the rope using two additional tucks.

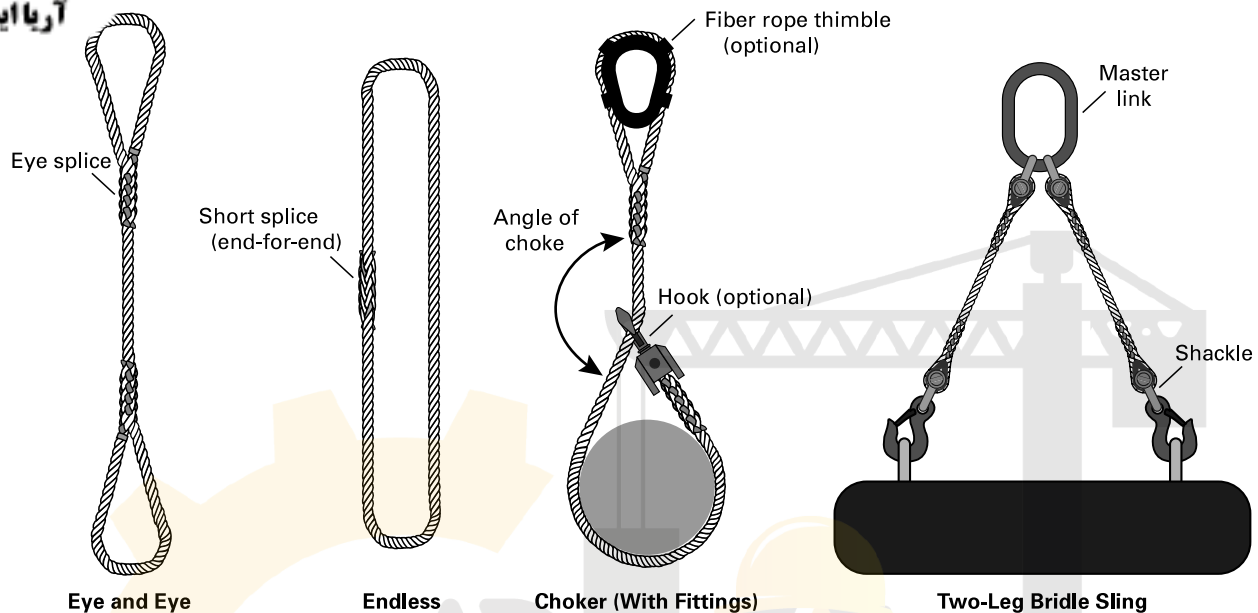
(c) Synthetic rope slings shall have a minimum undisturbed length of rope of 10 times the rope diameter between the last tucks of tuck splices or between the ends of the buried tails or strands of other types of splices.

(d) Knots, clips, or clamps shall not be used to fabricate slings.

(e) If thimbles do not have ears to prevent rotation, they should be lashed to the rope. Thimbles should be used in the sling whenever possible, and installed in a



Figure 9-4.0-1 Synthetic Fiber Rope Slings



GENERAL NOTE: Fittings designed for synthetic slings should be used.

manner that will prevent the thimble from rotating inside the eye or falling out of the eye.

### 9-4.3.2 Coatings

Finishes and coatings shall be compatible with the other components and not impair the performance of the sling.

### 9-4.3.3 Configurations

(a) Single-leg slings and two-leg, three-leg, and four-leg bridle slings used in straight-line, choker, and basket hitches are covered by this Chapter.

NOTE: A straight-line hitch is commonly referred to as a vertical hitch.

(b) Synthetic rope sling leg(s) shall be either eye-and-eye or endless.

## SECTION 9-4.4: DESIGN FACTOR

The design factor for synthetic rope slings shall be a minimum of 5.

## SECTION 9-4.5: RATED LOAD

(a) The sling manufacturer shall establish the sling's rated load.

(b) At a minimum, the rated load shall be based on the following factors:

- (1) component strength
- (2) number of legs
- (3) design factor
- (4) type of hitch (see Figure 9-4.5-1)

(5) angle of loading (see Figure 9-4.5-2)

(6) fabrication efficiency

## SECTION 9-4.6: PROOF TEST REQUIREMENTS

### 9-4.6.1 General

(a) Prior to initial use, all synthetic fiber rope slings incorporating previously used or welded fittings and all repaired slings shall be proof tested by the sling manufacturer or a qualified person.

(b) All other new synthetic fiber rope slings and fittings are not required to be proof tested unless specified by the purchaser.

### 9-4.6.2 Proof Load Requirements

(a) For single- or multiple-leg slings and endless slings, each leg shall be proof loaded to a minimum of 2 times the single-leg straight-line hitch rated load.

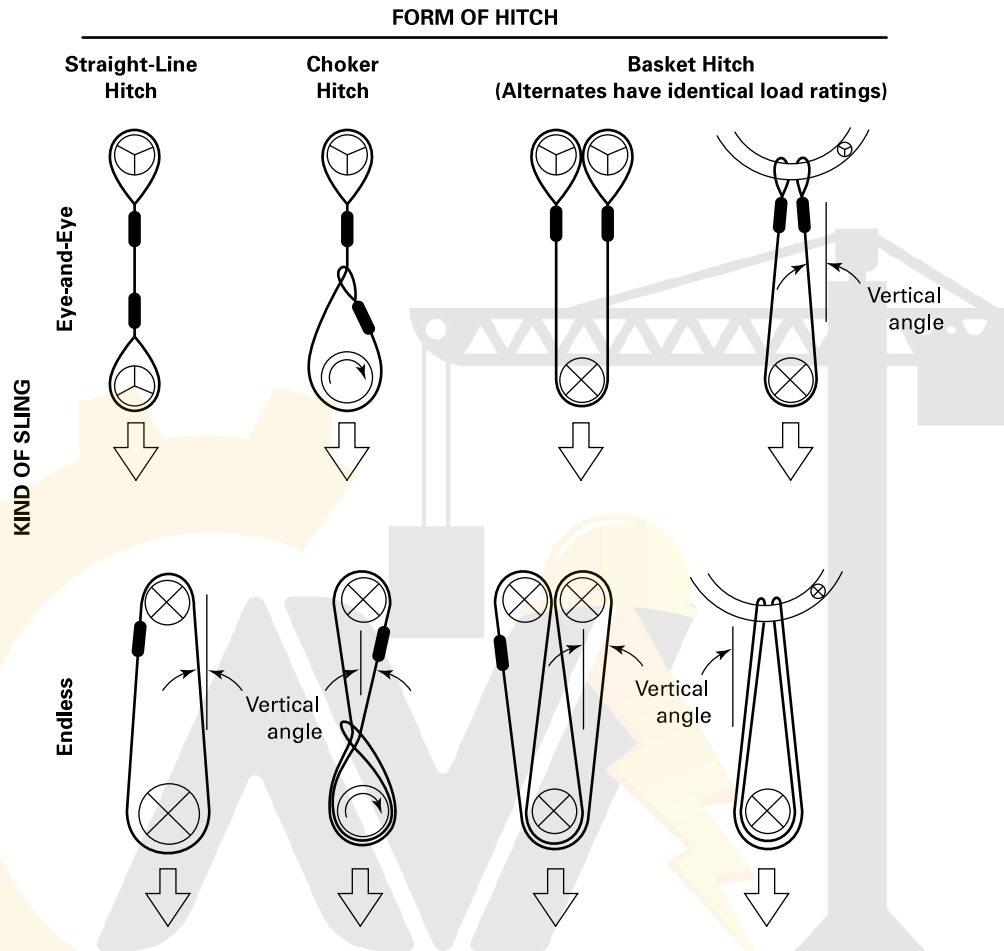
(b) The proof load for fittings attached to single legs shall be a minimum of 2 times the single-leg straight-line hitch rated load.

(c) Master links for two-leg bridle slings shall be proof loaded to a minimum of 4 times the single-leg straight-line hitch rated load.

(d) Master links for three-leg bridle slings shall be proof loaded to a minimum of 6 times the single-leg straight-line hitch rated load.

(e) Master links for four-leg bridle slings shall be proof loaded to a minimum of 8 times the single-leg straight-line hitch rated load.

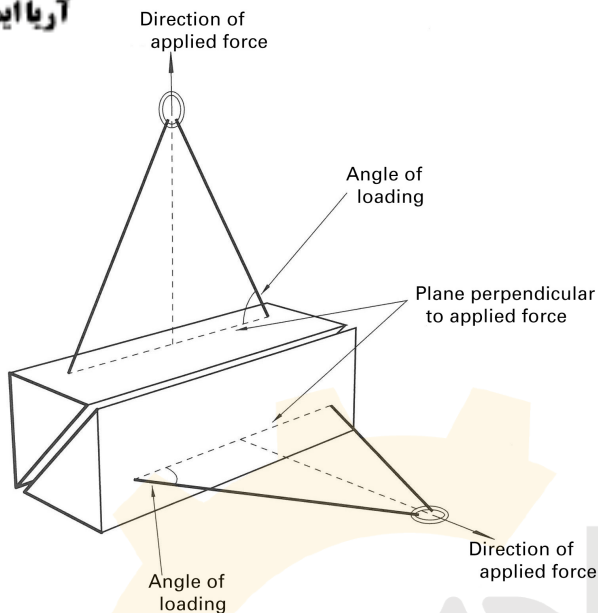
Figure 9-4.5-1 Hitch Types for Synthetic Rope Slings



The symbols below represent the load or support surfaces in contact with the rope sling. The contact surface diameter divided by the rope diameter is the designated  $D/d$  ratio as described in Figure 9-4.10.1-1 and is based on the  $D/d$  ratios indicated below.

- Represents a contact surface that shall have a diameter of curvature at least double the diameter of the rope from which the sling is made.
- Represents a contact surface that shall have a diameter of curvature at least 8 times the diameter of the rope.
- Represents a load in choker hitch and illustrates the rotary force on the load and/or the slippage of the rope in contact with the load. Diameter of curvature of load surface shall be at least double the diameter of the rope.

#### Figure 9-4.5-2 Angle of Loading



### SECTION 9-4.7: SLING IDENTIFICATION

#### 9-4.7.1 Identification Requirements

- Each sling shall be marked to show
- name or trademark of manufacturer, or if repaired, the entity performing repairs
  - manufacturer's code or stock number
  - rated load for at least one hitch type and the angle upon which it is based
  - type of fiber material
  - number of legs, if more than one

#### 9-4.7.2 Initial Sling Identification

Sling identification shall be done by the sling manufacturer.

#### 9-4.7.3 Maintenance of Sling Identification

Sling identification should be maintained by the user so as to be legible during the life of the sling.

#### 9-4.7.4 Replacement of Sling Identification

Replacement of the sling identification shall be considered a repair as specified in [paras. 9-4.9.6\(a\)](#) and [9-4.9.6\(b\)](#). Additional proof testing is not required.

### SECTION 9-4.8: EFFECTS OF ENVIRONMENT

#### 9-4.8.1 Temperature

Polyester and nylon rope slings shall not be used in contact with objects or at temperatures above 194°F (90°C) or below -40°F (-40°C).

#### 9-4.8.2 Chemically Active Environments

The strength of synthetic rope slings may be degraded by chemically active environments. This includes exposure to chemicals in the form of solids, liquids, gases, vapors, or fumes. The sling manufacturer or a qualified person should be consulted before slings are used in chemically active environments.

#### 9-4.8.3 Sunlight and Ultraviolet Light

The strength of synthetic rope slings is degraded by exposure to sunlight or ultraviolet light. The sling manufacturer or a qualified person should be consulted for additional retirement or inspection requirements. For additional degradation information, see CI 2001-04.

### SECTION 9-4.9: INSPECTION, REMOVAL, AND REPAIR

#### 9-4.9.1 General

(18)

All inspections shall be performed by a designated person. Any deficiency identified shall be examined and a determination made by a qualified person as to whether it constitutes a hazard, and if so, what additional steps need to be taken to address the hazard.

#### 9-4.9.2 Initial Inspection

Prior to use, all new, altered, modified, or repaired slings shall be inspected to verify compliance with the applicable provisions of this Chapter. Written records are not required for the initial inspection.

#### 9-4.9.3 Frequent Inspection

(18)

- Each shift, before the sling is used, a visual inspection for damage shall be performed. Slings used in severe or special service should be inspected before each use.
- Slings found with conditions such as those listed in [para. 9-4.9.5](#) shall be removed from service. Slings shall not be returned to service until approved by a qualified person.
- Written records are not required for frequent inspections.

#### 9-4.9.4 Periodic Inspection

(18)

(a) A complete inspection of the sling shall be performed. Inspection shall be conducted on the entire length, including splices and fittings. Slings found with conditions such as those listed in [para. 9-4.9.5](#) shall be removed from service. Slings shall not be returned to service until approved by a qualified person.

(b) *Periodic Inspection Frequency.* Periodic inspection intervals shall not exceed 1 yr [see (d)]. The frequency of periodic inspections should be based on

- frequency of sling use



severity of service conditions  
nature of load-handling activities  
(t) experience gained on the service life of slings used in similar circumstances

(c) Guidelines for the time intervals are  
(1) normal service — yearly  
(2) severe service — monthly to quarterly  
(3) special service — as recommended by a qualified person

(d) Periodic inspection is not required for a sling that is in storage or idle. However, if more than 1 yr has passed since the last periodic inspection, the sling shall be inspected in accordance with the requirements listed in (a) and (e) before being placed back into service.

(e) Documentation that the most recent periodic inspection was performed shall be maintained.

(f) Inspection records of individual slings are not required.

### 9-4.9.5 Removal Criteria

A synthetic rope sling shall be removed from service if any of the following conditions are present:

(a) missing or illegible sling identification (see Section 9-4.7)

(b) cuts, gouges, areas of extensive fiber breakage along the length, and abraded areas on the rope

(c) damage that is estimated to have reduced the effective diameter of the rope by more than 10%

(d) uniform fiber breakage along the major part of the length of the rope in the sling such that the entire rope appears covered with fuzz or whiskers

(e) inside the rope, fiber breakage, fused or melted fiber (observed by prying or twisting to open the strands) involving damage estimated at 10% of the fiber in any strand or the rope as a whole

(f) discoloration, brittle fibers, and hard or stiff areas that may indicate chemical damage, ultraviolet damage, or heat damage

(g) dirt and grit in the interior of the rope structure that is deemed excessive

(h) foreign matter that has permeated the rope and makes it difficult to handle and may attract and hold grit

(i) kinks or distortion in the rope structure, particularly if caused by forcibly pulling on loops (known as hockles)

(j) melted, hard, or charred areas that affect more than 10% of the diameter of the rope or affect several adjacent strands along the length that affect more than 10% of strand diameters

(k) poor condition of thimbles or other components manifested by corrosion, cracks, distortion, sharp edges, or localized wear

(l) for hooks, removal criteria as stated in ASME B30.10

(m) for rigging hardware, removal criteria as stated in ASME B30.26

(n) other conditions including visible damage that cause doubt as to the continued use of the sling

### 9-4.9.6 Repair

(a) Slings shall be repaired only by the sling manufacturer or a qualified person.

(b) A repaired sling shall be marked to identify the repairing entity per Section 9-4.7.

(c) Components used for sling repair shall comply with the provisions of this Chapter.

(d) The ropes that make up the sling shall not be respliced or knotted to effect repairs.

(e) All repairs shall comply with the proof test requirements of Section 9-4.6.

(f) Modifications or alterations to a sling shall conform to all repair provisions of this Chapter.

(g) Repair of hooks shall be as specified in ASME B30.10. Repair of below-the-hook lifting devices shall be as specified in ASME B30.20. Repair of all other fittings shall be as specified by the sling manufacturer, fitting manufacturer, or a qualified person.

## SECTION 9-4.10: OPERATING PRACTICES

### 9-4.10.1 Sling Selection

(a) Slings that appear to be damaged shall not be used unless inspected and accepted as usable under Section 9-4.9.

(b) Slings having suitable characteristics for the type of load, hitch, and environment shall be selected in accordance with the requirements of Sections 9-4.5 and 9-4.8.

(c) The rated load of the sling shall not be exceeded. When using a multiple-leg sling, no leg shall be loaded beyond its single-leg rating.

(d) When the choker hitch rating is not identified on the sling, the choker hitch rating shall be 75% of the sling's straight-line hitch rating unless other ratings are provided by the sling manufacturer or a qualified person.

(e) Rated loads for angles of choke less than 120 deg shall be determined by using the values in Table 9-4.10.1-1, or by consulting the sling manufacturer or a qualified person.

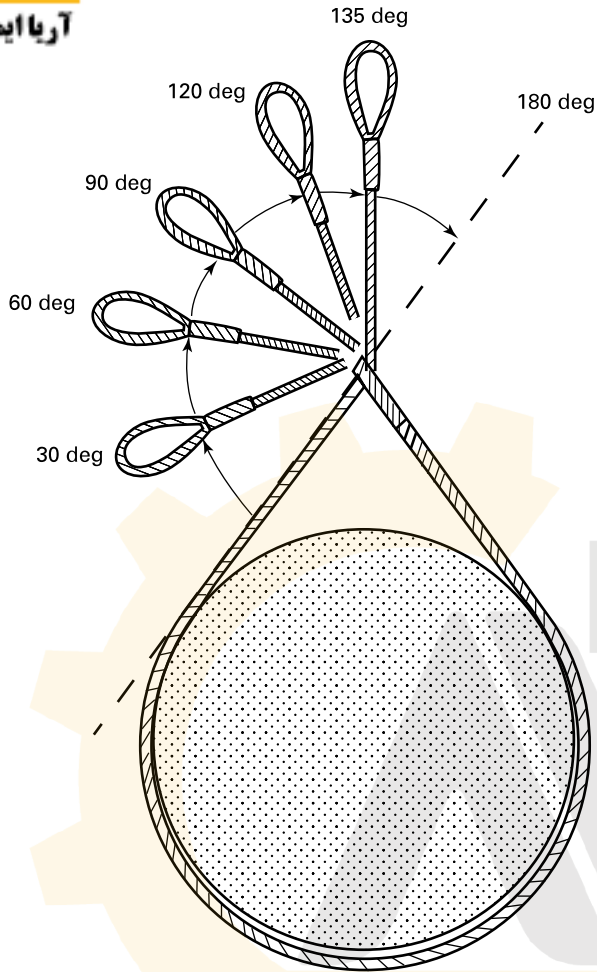
(f) When  $D/d$  ratios (see Figure 9-4.10.1-1) smaller than 8/1 are necessary in the body of the sling, the rated load of the sling shall be decreased. Consult the sling manufacturer or a qualified person.

(g) For multiple-leg slings used with nonsymmetrical loads, an analysis by a qualified person should be performed to prevent overloading of any leg.

(h) Multiple-leg slings shall be selected according to the sling's rated load based on the specific angle(s) as stated on the sling's identification. The rated load for use at other angles shall be provided by the sling manufacturer or a qualified person.

(i) Slings shall not be used at an angle of loading less than 30 deg except as recommended by the sling manufacturer or a qualified person.

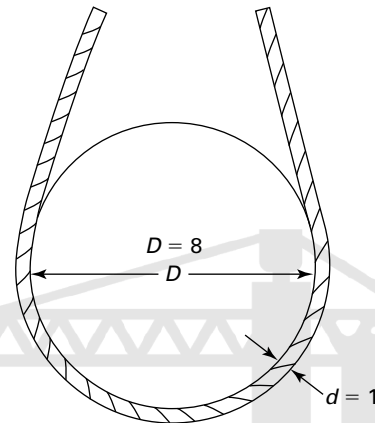
I-1 Angle of Choke: Synthetic Rope Slings



Angle of Choke, deg	Rated Capacity, % [Note (1)]
Over 120	100
90-120	87
60-89	74
30-59	62
0-29	49

NOTE: (1) Percent of sling rated capacity in a choker hitch.

Figure 9-4.10.1-1 D/d Ratio: Synthetic Rope Slings



GENERAL NOTE: When  $D$  is 8 times the component rope diameter  $d$ , the  $D/d$  is expressed as 8/1.

(j) Fittings shall be of a shape and size to ensure that they properly seat in the hook, shackle, or other load-handling device.

(k) When a sling leg is used as a basket hitch with the lower connector (hook) attaching to the master link (upper connector), the basket hitch rating shall be limited to its single-leg rating, unless the master link is rated to accommodate that configuration.

(l) Synthetic rope slings shall not be used to support suspended personnel platforms.

#### 9-4.10.2 Cautions to Personnel

(a) All portions of the human body shall be kept from between the sling and the load, and from between the sling and the hook, shackle, or other load-handling device.

(b) Personnel should not stand in line with or next to the leg(s) of a sling that is under tension.

(c) Personnel shall not stand or pass under a suspended load.

(d) Personnel shall not ride the sling.

(e) Synthetic rope slings shall not be used as bridles on suspended personnel platforms.

#### 9-4.10.3 Effects of Environment

(18)

(a) Slings should be stored in an area where they will not be subjected to mechanical, chemical, or ultraviolet damage or extreme temperatures (see Section 9-4.8).

(b) Do not store nylon ropes in areas where they may become impregnated with rust.

(c) Slings exposed to salt water should be thoroughly rinsed with fresh water to prevent mechanical damage from salt crystals when the rope dries.

(d) When slings or their fittings are to be exposed to acidic or alkaline fumes, vapors, sprays, mists, or liquids, the sling manufacturer or a qualified person should be consulted (see para. 9-4.8.2).



## Rigging Practices

Slings shall be shortened or adjusted only by methods approved by the sling manufacturer or a qualified person.

(b) Slings shall not be shortened or lengthened by knotting or twisting.

(c) The sling shall be hitched in a manner providing control of the load.

(d) Slings in contact with edges, corners, protrusions, or abrasive surfaces shall be protected with a material of sufficient strength, thickness, and construction to prevent damage.

(e) Shock loading should be avoided.

(f) Loads should not be rested on the sling.

(g) Slings should not be pulled from under a load when the load is resting on the sling.

(h) Twisting and kinking shall be avoided.

(i) During load-handling activities, with or without load, personnel shall be alert for possible snagging.

(j) When using multiple basket or choker hitches, the load should be rigged to prevent the sling from slipping or sliding along the load.

(k) When lifting with a basket hitch, the legs of the sling should contain or support the load from the sides, above the center of gravity, so that the load remains under control.

(l) Slings should not be dragged on the floor or over an abrasive surface.

(m) In a choker hitch, the choke point should only be on the sling body, not on a splice or fitting.

(n) Slings should not be constricted, bunched, or pinched by the load, hook, or any fitting.

(o) The load applied to the hook should be centered in the base (bowl) of the hook to prevent point loading on the hook, unless the hook is designed for point loading.

(p) An object in the eye of a sling should not be wider than one-third the length of the eye.

(q) When a hand-tucked sling is used, the sling, load, or load-handling device shall be prevented from rotating.

آريا ايمن آوات

## Chapter 9-5

# Synthetic Webbing Slings: Selection, Use, and Maintenance

### SECTION 9-5.0: SCOPE

Chapter 9-5 includes provisions that apply to synthetic webbing slings (see Figures 9-5.0-1 and 9-5.0-2).

### SECTION 9-5.1: TRAINING

Synthetic webbing sling users shall be trained in the selection, inspection, cautions to personnel, effects of the environment, and rigging practices as covered by this Chapter.

### SECTION 9-5.2: COMPONENTS

#### 9-5.2.1 Webbing

The synthetic webbing shall be manufactured and tested in accordance with WSTDA-WB-1.

#### 9-5.2.2 Thread

The thread used in the fabrication of synthetic webbing slings shall be manufactured and tested in accordance with WSTDA-TH-1.

#### (18) 9-5.2.3 Fittings

(a) Fittings shall have sufficient strength to sustain 2 times the rated load of the sling without visible permanent deformation.

(b) Fitting surfaces in contact with the sling shall be finished to remove edges that could damage the sling.

(c) When employed, hooks shall meet the requirements of ASME B30.10.

(d) When employed, rigging hardware shall meet the requirements of ASME B30.26.

#### (18) 9-5.2.4 Other Components

Slings that employ synthetic webbings, thread, or fittings other than those listed in paras. 9-5.2.1 through 9-5.2.3 may be used. When such materials are employed, the sling manufacturer or a qualified person shall provide specific data regarding deviations from the applicable sections of this Chapter. These slings shall comply with all other requirements of this Chapter.

### SECTION 9-5.3: FABRICATION AND CONFIGURATIONS

#### 9-5.3.1 Fabrication

(a) Stitching shall be the method for fabricating synthetic webbing slings.

(b) The thread shall be the same yarn type as the sling webbing.

#### 9-5.3.2 Coatings

Finishes and coatings shall be compatible with the other components and not impair the performance of the sling.

#### 9-5.3.3 Configurations

(a) Single-leg slings and two-leg, three-leg, and four-leg bridle slings used in straight-line, choker, and basket hitches are covered by this Chapter.

NOTE: A straight-line hitch is commonly referred to as a vertical hitch.

(b) Other configurations may be used. When used, the sling manufacturer or a qualified person shall provide specific data. These slings shall comply with all other requirements of this Chapter.

### SECTION 9-5.4: DESIGN FACTOR

The design factor for synthetic webbing slings shall be a minimum of 5.

### SECTION 9-5.5: RATED LOAD

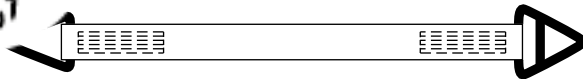
(a) The sling manufacturer shall establish the sling's rated load.

(b) At a minimum, the rated load shall be based on the following factors:

- (1) component strength
- (2) number of legs
- (3) design factor
- (4) type of hitch
- (5) angle of loading (see Figure 9-5.5-1)
- (6) fabrication efficiency

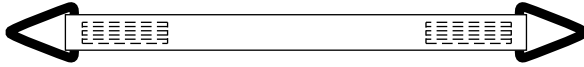


Figure 9-5.0-1 Synthetic Webbing Slings



Sling made with a triangle fitting on one end and a slotted triangle choker fitting on the other end. It can be used in a straight-line, basket, or choker hitch.

Type I



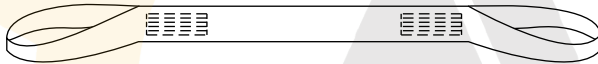
Sling made with a triangle fitting on both ends. It can be used in a straight-line or basket hitch only.

Type II



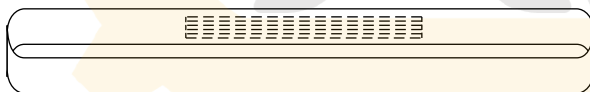
Sling made with a flat loop eye on each end with loop eye opening on same plane as sling body. This type of sling is sometimes called a flat eye-and-eye, eye-and-eye, or double-eye sling.

Type III



Sling made with both loop eyes formed as in Type III, except that the loop eyes are turned to form a loop eye that is at a right angle to the plane of the sling body. This type of sling is commonly referred to as a twisted-eye sling.

Type IV



Endless sling, sometimes referred to as a grommet. It is a continuous loop formed by joining the ends of the webbing together.

Type V



Return-eye (reversed-eye) sling is formed by using multiple widths of webbing held edge-to-edge. A wear pad is attached on one or both sides of the sling body and on one or both sides of the loop eyes to form a loop eye at each end which is at a right angle to the plane of the sling body.

Type VI

Figure 9-5.0-2 Synthetic Webbing Sling Nomenclature

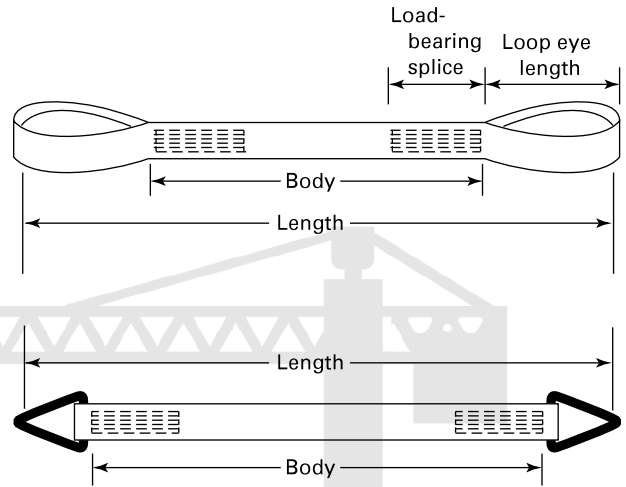
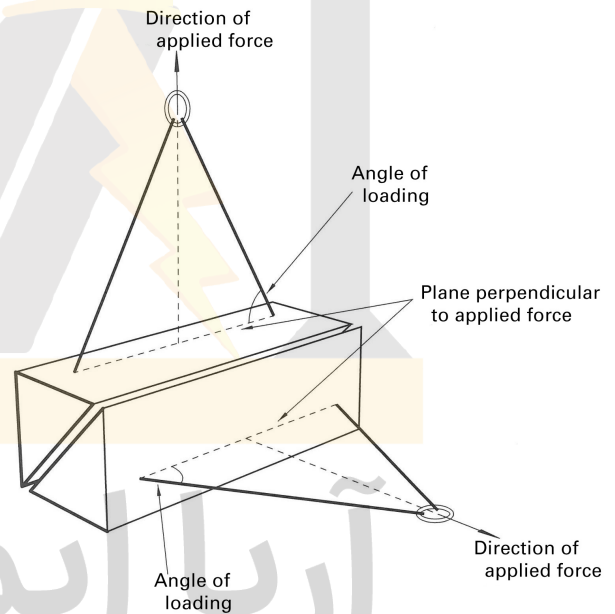


Figure 9-5.5-1 Angle of Loading







## 9.6: PROOF TEST REQUIREMENTS

### 9.6.1 General

(a) Prior to initial use, all synthetic webbing slings incorporating previously used or welded fittings and all repaired slings shall be proof tested by the sling manufacturer or a qualified person.

(b) All other new synthetic webbing slings and fittings are not required to be proof tested unless specified by the purchaser.

### 9-5.6.2 Proof Load Requirements

(a) For single- or multiple-leg slings and endless slings, each leg shall be proof loaded to 2 times the single-leg straight-line hitch rated load.

(b) The proof load for fittings attached to single legs shall be a minimum of 2 times the single-leg straight-line hitch rated load.

(c) Master links for two-leg bridle slings shall be proof loaded to a minimum of 4 times the single-leg straight-line hitch rated load.

(d) Master links for three-leg bridle slings shall be proof loaded to a minimum of 6 times the single-leg straight-line hitch rated load.

(e) Master links for four-leg bridle slings shall be proof loaded to a minimum of 8 times the single-leg straight-line hitch rated load.

## SECTION 9-5.7: SLING IDENTIFICATION

### 9-5.7.1 Identification Requirements

Each sling shall be marked to show

(a) name or trademark of manufacturer, or if repaired, the entity performing repairs

(b) manufacturer's code or stock number

(c) rated load for at least one hitch type and the angle upon which it is based

(d) type of synthetic web material

(e) number of legs, if more than one

### 9-5.7.2 Initial Sling Identification

Sling identification shall be done by the sling manufacturer.

### 9-5.7.3 Maintenance of Sling Identification

Sling identification should be maintained by the user so as to be legible during the life of the sling.

### 9-5.7.4 Replacement of Sling Identification

Replacement of the sling identification shall be considered a repair as specified in [paras. 9-5.9.6\(a\)](#) and [9-5.9.6\(b\)](#). Additional proof testing is not required.

## SECTION 9-5.8: EFFECTS OF ENVIRONMENT

### 9-5.8.1 Temperature

Polyester and nylon webbing slings shall not be used in contact with an object or at temperatures in excess of 194°F (90°C) or below -40°F (-40°C).

### 9-5.8.2 Chemically Active Environments

The strength of synthetic webbing slings may be degraded by chemically active environments. This includes exposure to chemicals in the form of solids, liquids, gases, vapors, or fumes. The sling manufacturer or qualified person should be consulted before slings are used in chemically active environments.

### 9-5.8.3 Sunlight and Ultraviolet Light

The strength of synthetic webbing slings is degraded by exposure to sunlight or ultraviolet light. The sling manufacturer or a qualified person should be consulted for additional retirement or inspection requirements. For additional degradation information, see WSTDA-UV-Sling.

## SECTION 9-5.9: INSPECTION, REMOVAL, AND REPAIR

### 9-5.9.1 General

(18)

All inspections shall be performed by a designated person. Any deficiency identified shall be examined and a determination made by a qualified person as to whether it constitutes a hazard, and if so, what additional steps need to be taken to address the hazard.

### 9-5.9.2 Initial Inspection

Prior to use, all new, altered, modified, or repaired slings shall be inspected to verify compliance with the applicable provisions of this Chapter. Written records are not required for initial inspection.

### 9-5.9.3 Frequent Inspection

(18)

(a) Each shift, before the sling is used, a visual inspection for damage shall be performed. Slings used in severe or special service should be inspected before each use.

(b) Slings found with conditions such as those listed in [para. 9-5.9.5](#) shall be removed from service. Slings shall not be returned to service until approved by a qualified person.

(c) Written records are not required for frequent inspections.

### 9-5.9.4 Periodic Inspection

(18)

(a) A complete inspection of the sling shall be performed. Inspection shall be conducted on the entire length, including splices and fittings. Slings found with



such as those listed in [para. 9-5.9.5](#) shall be removed from service. Slings shall not be returned to service until approved by a qualified person.

(b) *Periodic Inspection Frequency.* Periodic inspection intervals shall not exceed 1 yr [see (d)]. The frequency of periodic inspections should be based on

- (1) frequency of sling use
- (2) severity of service conditions
- (3) nature of load-handling activities
- (4) experience gained on the service life of slings used in similar circumstances

(c) Guidelines for the time intervals are

- (1) normal service — yearly
- (2) severe service — monthly to quarterly
- (3) special service — as recommended by a qualified person

(d) Periodic inspection is not required for a sling that is in storage or idle. However, if more than 1 yr has passed since the last periodic inspection, the sling shall be inspected in accordance with the requirements listed in (a) and (e) before being placed back into service.

(e) Documentation that the most recent periodic inspection was performed shall be maintained.

(f) Inspection records of individual slings are not required.

### 9-5.9.5 Removal Criteria

A synthetic webbing sling shall be removed from service if any of the following conditions are present:

(a) missing or illegible sling identification (see [Section 9-5.7](#))

- (b) acid or caustic burns
- (c) melting or charring of any part of the sling
- (d) holes, tears, cuts, or snags
- (e) broken or worn stitching in load-bearing splices
- (f) excessive abrasive wear
- (g) knots in any part of the sling
- (h) discoloration and brittle or stiff areas on any part of the sling, which may mean chemical or ultraviolet/sunlight damage

(i) fittings that are pitted, corroded, cracked, bent, twisted, gouged, or broken

(j) for hooks, removal criteria as stated in ASME B30.10

(k) for rigging hardware, removal criteria as stated in ASME B30.26

(l) other conditions, including visible damage, that cause doubt as to the continued use of the sling

### 9-5.9.6 Repair

(a) Slings shall be repaired only by the sling manufacturer or a qualified person.

(b) A repaired sling shall be marked to identify the repairing entity per [Section 9-5.7](#).

(c) Components used for sling repair shall comply with the provisions of this Chapter.

(d) There shall be no repairs to a load-bearing splice.

(e) Webbing material meeting the removal criteria in [para. 9-5.9.5](#) shall not be repaired, but may be replaced only if approved by a sling manufacturer or a qualified person.

(f) Repair of hooks shall be as specified in ASME B30.10. Repair of below-the-hook lifting devices shall be as specified in ASME B30.20. Repair of all other fittings shall be as specified by the sling manufacturer, fitting manufacturer, or a qualified person.

(g) All repairs shall comply with the proof test requirements of [Section 9-5.6](#).

(h) Modifications or alterations to a sling shall conform to all repair provisions of this Chapter.

## SECTION 9-5.10: OPERATING PRACTICES

### 9-5.10.1 Sling Selection

(a) Slings that appear to be damaged shall not be used unless inspected and accepted as usable under [Section 9-5.9](#).

(b) Slings having suitable characteristics for the type of load, hitch, and environment shall be selected in accordance with the requirements of [Sections 9-5.5](#) and [9-5.8](#).

(c) The rated load of the sling shall not be exceeded. When using a multiple-leg sling, no leg shall be loaded beyond its single-leg rating.

(d) When the choker hitch rating is not identified on the sling, the choker hitch rating shall be 80% of the sling's straight-line hitch rating, unless other ratings are provided by the sling manufacturer or a qualified person.

(e) Rated loads for angles of choke less than 120 deg shall be determined by using the values in [Table 9-5.10.1-1](#), or by consulting the sling manufacturer or a qualified person.

(f) For multiple-leg slings used with nonsymmetrical loads, an analysis by a qualified person should be performed to prevent overloading of any leg.

(g) Multiple-leg slings shall be selected according to the sling's rated load based on the specific angle(s) as stated on the sling's identification. The rated load for use at other angles shall be provided by the sling manufacturer or a qualified person.

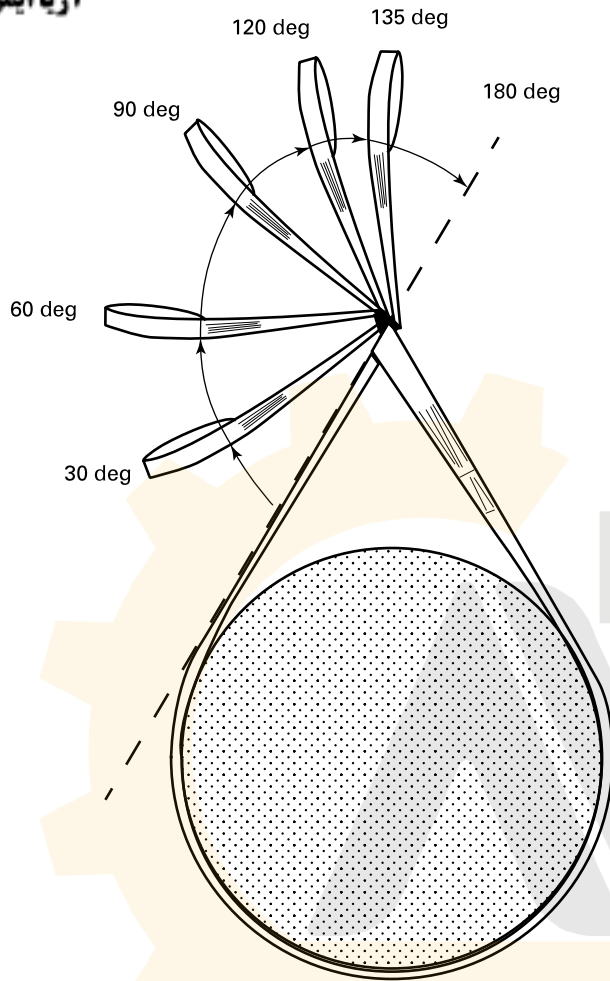
(h) Slings shall not be used at an angle of loading less than 30 deg except as recommended by the sling manufacturer or a qualified person.

(i) When a sling leg is used as a basket hitch with the lower connector (hook) attaching to the master link (upper connector), the basket hitch rating shall be limited to its single-leg rating, unless the master link is rated to accommodate that configuration.

(j) Fittings shall be of a shape and size to ensure that they properly seat in the hook, shackle, or other load-handling device.

(k) Synthetic webbing slings shall not be used to support suspended personnel platforms.

**9-5.10.1 Angle of Choke: Synthetic Webbing Slings**



Angle of Choke, deg	Rated Capacity, % [Note (1)]
Over 120	100
90-120	87
60-89	74
30-59	62
0-29	49

NOTE: (1) Percent of sling rated capacity in a choker hitch.

**9-5.10.2 Cautions to Personnel**

- (a) All portions of the human body shall be kept from between the sling and the load, and from between the sling and the hook, shackle, or other load-handling device.
- (b) Personnel should not stand in line with or next to the leg(s) of a sling that is under tension.
- (c) Personnel shall not stand or pass under a suspended load.
- (d) Personnel shall not ride the sling.

**9-5.10.3 Effects of Environment**

(18)

- (a) Slings should be stored in an area where they will not be subjected to mechanical, chemical, or ultraviolet damage or extreme temperatures (see Section 9-5.8).
- (b) When extensive exposure to sunlight or ultraviolet light is experienced by nylon or polyester webbing slings, the sling manufacturer should be consulted for recommended inspection procedure.
- (c) When slings or their fittings are to be exposed to acidic or alkaline fumes, vapors, sprays, mists, or liquids, the sling manufacturer or a qualified person should be consulted (see para. 9-5.8.2).

**9-5.10.4 Rigging Practices**

- (a) Slings shall be shortened or adjusted only by methods approved by the sling manufacturer or a qualified person.
- (b) Slings shall not be shortened or lengthened by knotting or twisting.
- (c) The sling shall be hitched in a manner providing control of the load.
- (d) Slings in contact with edges, corners, protrusions, or abrasive surfaces shall be protected with a material of sufficient strength, thickness, and construction to prevent damage.
- (e) Shock loading should be avoided.
- (f) Loads should not be rested on the sling.
- (g) Slings should not be pulled from under a load when the load is resting on the sling.
- (h) Twisting shall be avoided.
- (i) During load-handling activities, with or without load, personnel shall be alert for possible snagging.
- (j) When using multiple basket or choker hitches, the load should be rigged to prevent the sling from slipping or sliding along the load.
- (k) When lifting with a basket hitch, the legs of the sling should contain or support the load from the sides, above the center of gravity, so that the load remains under control.
- (l) Slings should not be dragged on the floor or over an abrasive surface.
- (m) In a choker hitch, the choke point should only be on the sling body, not on a load-bearing splice or fitting.
- (n) Slings should not be constricted, bunched, or pinched by the load, hook, or any fitting.
- (o) The load applied to the hook should be centered in the base (bowl) of the hook to prevent point loading on the hook, unless the hook is designed for point loading.
- (p) An object in the eye of a sling should not be wider than one-third the length of the eye.

## Chapter 9-6 Polyester Roundslings: Selection, Use, and Maintenance

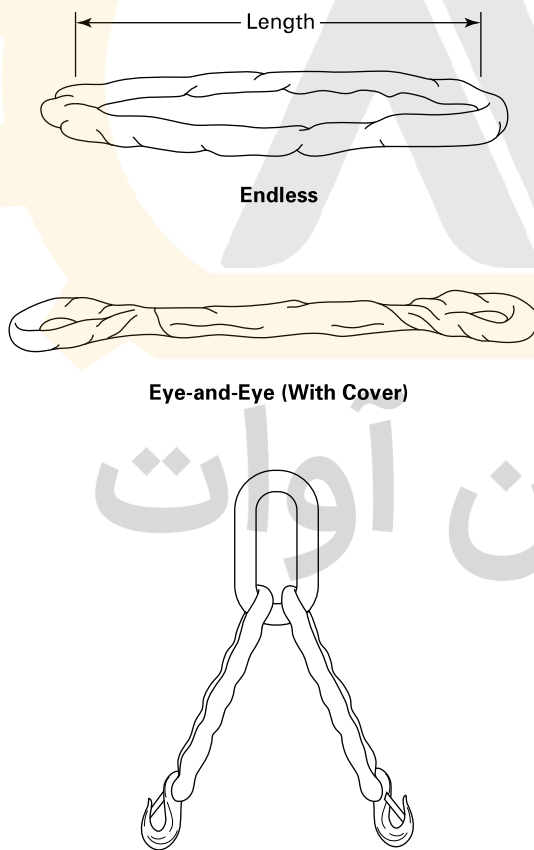
### SECTION 9-6.0: SCOPE

Chapter 9-6 includes provisions that apply to polyester roundslings (see Figure 9-6.0-1).

### SECTION 9-6.1: TRAINING

Polyester roundsling users shall be trained in the selection, inspection, cautions to personnel, effects of environment, and rigging practices as covered by this Chapter.

Figure 9-6.0-1 Polyester Roundsling Types



Two-Leg Bridle Sling

### SECTION 9-6.2: COMPONENTS

#### 9-6.2.1 Core

(18)

The finished core shall be of polyester fiber, and tested according to the pin size limits as stated in WSTDA-RS-1 or CI 1905.

NOTE: See Section 9-6.3 concerning covers and thread.

#### 9-6.2.2 Fittings

(18)

(a) Fittings shall have sufficient strength to sustain twice the rated load of the sling without visible permanent deformation.

(b) Fitting surfaces in contact with the sling shall be finished to remove edges that could damage the sling.

(c) When employed, hooks shall meet the requirements of ASME B30.10.

(d) When employed, rigging hardware shall meet the requirements of ASME B30.26.

#### 9-6.2.3 Other Components

(18)

Slings that employ core yarns or fittings other than those listed in paras. 9-6.2.1 and 9-6.2.2 may be used. When the core and cover are of different materials, the thread should be of the same material as the core. When other components are employed, the sling manufacturer or a qualified person shall provide specific data regarding deviations from the applicable sections of this Chapter. These slings shall comply with all other requirements of this Chapter.

### SECTION 9-6.3: FABRICATION AND CONFIGURATIONS

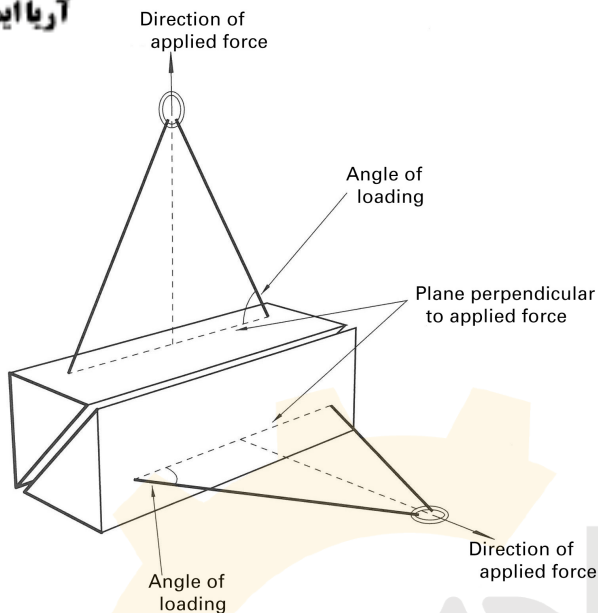
#### 9-6.3.1 Fabrication

Polyester roundslings shall be fabricated from core yarns wound together with multiple turns and enclosed in protective cover(s). Covers shall be made from synthetic material.

#### 9-6.3.2 Thread

The thread used to secure the cover in the fabrication of polyester roundslings shall be polyester thread manufactured and tested in accordance with WSTDA-TH-1.

Figure 9-6.5-1 Angle of Loading



### 9-6.3.3 Coatings

Finishes and coatings shall be compatible with the other components and not impair the performance of the sling.

### 9-6.3.4 Configurations

(a) Single-leg slings and two-leg, three-leg, and four-leg bridle slings used in straight-line, choker, and basket hitches are covered by this Chapter.

NOTE: A straight-line hitch is commonly referred to as a vertical hitch.

(b) Other configurations may be used. When used, the sling manufacturer or a qualified person shall provide specific data. These slings shall comply with all other requirements of this Chapter.

## SECTION 9-6.4: DESIGN FACTOR

The design factor for roundslings shall be a minimum of 5.

## SECTION 9-6.5: RATED LOAD

(a) The sling manufacturer shall establish the sling's rated load.

(b) At a minimum, the rated load shall be based on the following factors:

- (1) component strength
- (2) number of legs
- (3) design factor
- (4) type of hitch
- (5) angle of loading (see Figure 9-6.5-1)
- (6) fabrication efficiency

## SECTION 9-6.6: PROOF TEST REQUIREMENTS

### 9-6.6.1 General

(a) Prior to initial use, all polyester roundslings incorporating previously used or welded fittings and all repaired slings shall be proof tested by the sling manufacturer or a qualified person.

(b) All other polyester roundslings and fittings are not required to be proof tested unless specified by the purchaser.

### 9-6.6.2 Proof Load Requirements

(a) For single- or multiple-leg slings and endless slings, each leg shall be proof loaded to a minimum of 2 times the single-leg straight-line hitch rated load.

(b) The proof load for fittings attached to single legs shall be a minimum of 2 times the single-leg straight-line hitch rated load.

(c) Master links for two-leg bridle slings shall be proof loaded to a minimum of 4 times the single-leg straight-line hitch rated load.

(d) Master links for three-leg bridle slings shall be proof loaded to a minimum of 6 times the single-leg straight-line hitch rated load.

(e) Master links for four-leg bridle slings shall be proof loaded to a minimum of 8 times the single-leg straight-line hitch rated load.

## SECTION 9-6.7: SLING IDENTIFICATION

### 9-6.7.1 Identification Requirements

Each sling shall be marked to show

- (a) name or trademark of manufacturer, or if repaired, the entity performing repairs
- (b) manufacturer's code or stock number
- (c) rated load for at least one hitch type and the angle upon which it is based
- (d) core material
- (e) cover material, if different from core material
- (f) number of legs, if more than one

### 9-6.7.2 Initial Sling Identification

Sling identification shall be done by the sling manufacturer.

### 9-6.7.3 Maintenance of Sling Identification

Sling identification should be maintained by the user so as to be legible during the life of the sling.

### 9-6.7.4 Replacement of Sling Identification

Replacement of the sling identification shall be considered a repair as specified in paras. 9-6.9.6(a) and 9-6.9.6(b). Additional proof testing is not required.



## 9-6.8: EFFECTS OF ENVIRONMENT

### 9-6.8.1 Temperature

Polyester roundslings shall not be used in contact with objects or at temperatures above 194°F (90°C) or below -40°F (-40°C).

### 9-6.8.2 Chemically Active Environments

The strength of polyester roundslings may be degraded by chemically active environments. This includes exposure to chemicals in the form of solids, liquids, gases, vapors, or fumes. The sling manufacturer or qualified person should be consulted before slings are used in chemically active environments.

## SECTION 9-6.9: INSPECTION, REMOVAL, AND REPAIR

### (18) 9-6.9.1 General

All inspections shall be performed by a designated person. Any deficiency identified shall be examined and a determination made by a qualified person as to whether it constitutes a hazard, and if so, what additional steps need to be taken to address the hazard.

### 9-6.9.2 Initial Inspection

Prior to use, all new, altered, modified, or repaired slings shall be inspected to verify compliance with the applicable provisions of this Chapter. Written records are not required for initial inspections.

### (18) 9-6.9.3 Frequent Inspection

(a) Each shift, before the sling is used, a visual inspection for damage shall be performed. Slings used in severe or special service should be inspected before each use.

(b) Slings found with conditions such as those listed in [para. 9-6.9.5](#) shall be removed from service. Slings shall not be returned to service until approved by a qualified person.

(c) Written records are not required for frequent inspections.

### (18) 9-6.9.4 Periodic Inspection

(a) A complete inspection of the sling shall be performed. Inspection shall be conducted on the entire length including fittings. Slings found with conditions such as those listed in [para. 9-6.9.5](#) shall be removed from service. Slings shall not be returned to service until approved by a qualified person.

(b) *Periodic Inspection Frequency.* Periodic inspection intervals shall not exceed 1 yr [see (d)]. The frequency of periodic inspections should be based on

- (1) frequency of sling use
- (2) severity of service conditions

(3) nature of load-handling activities  
(4) experience gained on the service life of slings used in similar circumstances

(c) Guidelines for the time intervals are

- (1) normal service — yearly
- (2) severe service — monthly to quarterly
- (3) special service — as recommended by a qualified person

person

(d) Periodic inspection is not required for a sling that is in storage or idle. However, if more than 1 yr has passed since the last periodic inspection, the sling shall be inspected before being placed back into service in accordance with the requirements listed in (a) and (e).

(e) Documentation that the most recent periodic inspection was performed shall be maintained.

(f) Inspection records of individual slings are not required.

### 9-6.9.5 Removal Criteria

(18)

A polyester roundsling shall be removed from service if any of the following conditions are present:

(a) missing or illegible sling identification (see [Section 9-6.7](#))

(b) acid or caustic burns

(c) evidence of heat damage

(d) holes, tears, cuts, abrasive wear, or snags that expose the core yarns

(e) broken or damaged core yarns

(f) weld splatter that exposes core yarns

(g) knots in the roundsling, except for core yarn knots inside the cover installed by the manufacturer during the fabrication process

(h) fittings that are pitted, corroded, cracked, bent, twisted, gouged, or broken

(i) for hooks, removal criteria as stated in ASME B30.10  
(j) for rigging hardware, removal criteria as stated in ASME B30.26

(k) other conditions, including visible damage, that cause doubt as to the continued use of the sling

### 9-6.9.6 Repair

(a) Slings shall be repaired only by the sling manufacturer or a qualified person.

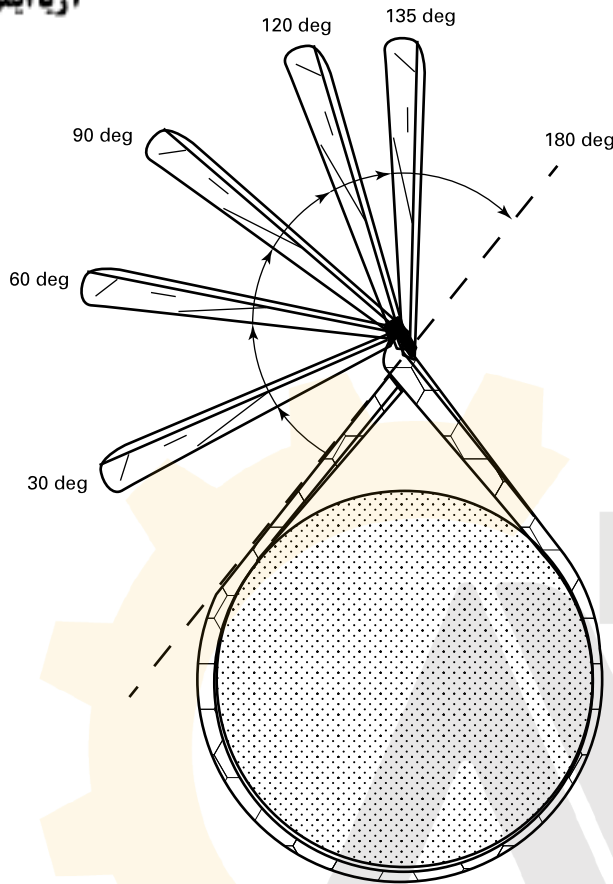
(b) A repaired sling shall be marked to identify the repairing entity per [Section 9-6.7](#).

(c) Components used for sling repair shall comply with the provisions of this Chapter.

(d) Repair of hooks shall be as specified in ASME B30.10. Repair of below-the-hook lifting devices shall be as specified in ASME B30.20. Repair of all other fittings shall be as specified by the sling manufacturer, fitting manufacturer, or a qualified person.

(e) All repairs shall comply with the proof test requirements of [Section 9-6.6](#).

### 9.1-1 Angle of Choke: High Performance Roundslings



Angle of Choke, deg	Rated Capacity, % [Note (1)]
Over 120	100
90-120	87
60-89	74
30-59	62
0-29	49

NOTE: (1) Percent of sling rated capacity in a choker hitch.

(f) Modifications or alterations to a sling shall conform to all repair provisions of this Chapter.

(g) There shall be no repairs to core yarns.

## SECTION 9-6.10: OPERATING PRACTICES

### (18) 9-6.10.1 Sling Selection

(a) Slings that appear to be damaged shall not be used unless inspected and accepted as usable under Section 9-6.9.

(b) Slings having suitable characteristics for the type of load, hitch, and environment shall be selected in accordance with the requirements of Sections 9-6.5 and 9-6.8.

(c) The rated load of the sling shall not be exceeded. When using a multiple-leg sling, no leg shall be loaded beyond its single-leg rating.

(d) When the choker hitch rating is not identified on the sling, the choker hitch rating shall be 80% of the sling's straight-line hitch rating, unless other ratings are provided by the sling manufacturer or a qualified person.

(e) Rated loads for angles of choke less than 120 deg shall be determined by using the values in Table 9-6.10.1-1 or by consulting the sling manufacturer or a qualified person.

(f) For multiple-leg slings used with nonsymmetrical loads, an analysis by a qualified person should be performed to prevent overloading of any leg.

(g) Multiple-leg slings shall be selected according to the sling's rated load based on the specific angle(s) as stated on the sling's identification. The rated load for use at other angles shall be provided by the sling manufacturer or a qualified person.

(h) Slings shall not be used at an angle of loading less than 30 deg except as recommended by the sling manufacturer or a qualified person.

(i) When a sling leg is used as a basket hitch with the lower connector (hook) attaching to the master link (upper connector), the basket hitch rating shall be limited to its single-leg rating, unless the master link is rated to accommodate that configuration.

(j) Fittings shall be of a shape and size to ensure that they are properly seated in the hook, shackle, or other load-handling device. The rated load of a polyester round-sling may need to be reduced depending on the shape and size of an attached fitting or other load-handling device. Connection fittings or hardware shall be in accordance with WSTDA-RS-1, Section 4.7 or as recommended by the sling manufacturer or a qualified person.

(k) Polyester roundslings shall not be used to support suspended personnel platforms.

### 9-6.10.2 Cautions to Personnel

(a) All portions of the human body shall be kept from between the sling and the load, and from between the sling and the hook, shackle, or other load-handling device.

(b) Personnel should not stand in line with or next to the leg(s) of a sling that is under tension.

(c) Personnel shall not stand or pass under a suspended load.

(d) Personnel shall not ride the sling.

### 9-6.10.3 Effects of Environment

(18)

(a) Slings should be stored in an area where they will not be subjected to mechanical, chemical, or ultraviolet damage or extreme temperatures (see Section 9-6.8).

(b) When slings or their fittings are to be exposed to acidic or alkaline fumes, vapors, sprays, mists, or liquids, the sling manufacturer or a qualified person should be consulted (see para. 9-6.8.2).



## Rigging Practices

Slings shall be shortened or adjusted only by methods approved by the sling manufacturer or a qualified person.

(b) Slings shall not be shortened or lengthened by knotting or twisting.

(c) Slings shall be hitched in a manner providing control of the load.

(d) Slings in contact with edges, corners, protrusions, abrasive surfaces, or connecting hardware shall be protected with a material of sufficient strength, thickness, and construction to prevent damage unless the edges are adequately rounded to a suitable radius in accordance with WSTDA-RS-1, Section 4.6, the sling manufacturer, or a qualified person.

(e) Shock loading should be avoided.

(f) Loads should not be rested on the sling.

(g) Slings should not be pulled from under a load when the load is resting on the sling.

(h) Twisting shall be avoided.

(i) During load-handling activities, with or without load, personnel shall be alert for possible snagging.

(j) When using multiple-basket or choker hitches, the load should be rigged to prevent the sling from slipping or sliding along the load.

(k) When lifting with a basket hitch, the legs of the sling should contain or support the load from the sides, above the center of gravity, so that the load remains under control.

(l) Slings should not be dragged on the floor or over an abrasive surface.

(m) In a choker hitch, the choke point should only be on the sling body, not on a cover splice or fitting.

(n) Slings should not be constricted, bunched, or pinched by the load, hook, or any fitting.

(o) The load applied to the hook should be centered in the base (bowl) of the hook to prevent point loading on the hook, unless the hook is designed for point loading.

آريا ايمن آوات



(18)

## Chapter 9-7

# High Performance Roundslings: Selection, Use, and Maintenance

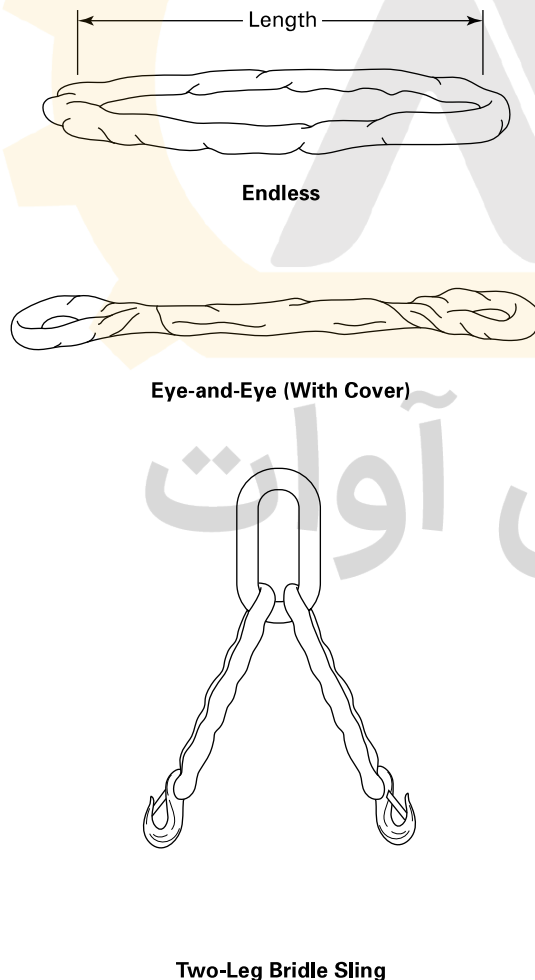
### SECTION 9-7.0: SCOPE

Chapter 9-7 includes provisions that apply to high performance (HP) roundslings (see [Figure 9-7.0-1](#)).

### SECTION 9-7.1: TRAINING

HP roundsling users shall be trained in the selection, inspection, cautions to personnel, effects of environment, and rigging practices as covered by this Chapter.

**Figure 9-7.0-1 High Performance Roundsling Types**



### SECTION 9-7.2: COMPONENTS

#### 9-7.2.1 Core

The finished core shall be comprised of a majority of high tenacity fiber as described in CI 1905.

#### 9-7.2.2 Fittings

(a) Fittings shall have sufficient strength to sustain twice the rated load of the sling without permanent deformation.

(b) All fitting surfaces in contact with the sling shall be finished to remove all edges that could potentially damage the sling.

(c) When employed, hooks shall meet the requirements of ASME B30.10.

(d) When employed, rigging hardware shall meet the requirements of ASME B30.26.

#### 9-7.2.3 Other Components

Slings that employ core yarns or fittings other than those listed in [paras. 9-7.2.1](#) and [9-7.2.2](#) may be used. When other components are employed, the sling manufacturer or a qualified person shall provide specific data regarding deviations from the applicable sections of this Chapter. These slings shall comply with all other requirements of this Chapter.

### SECTION 9-7.3: FABRICATION AND CONFIGURATIONS

#### 9-7.3.1 Fabrication

HP roundslings shall be fabricated from core yarns wound together with multiple turns and enclosed in a cover(s). Covers shall be made from synthetic material.

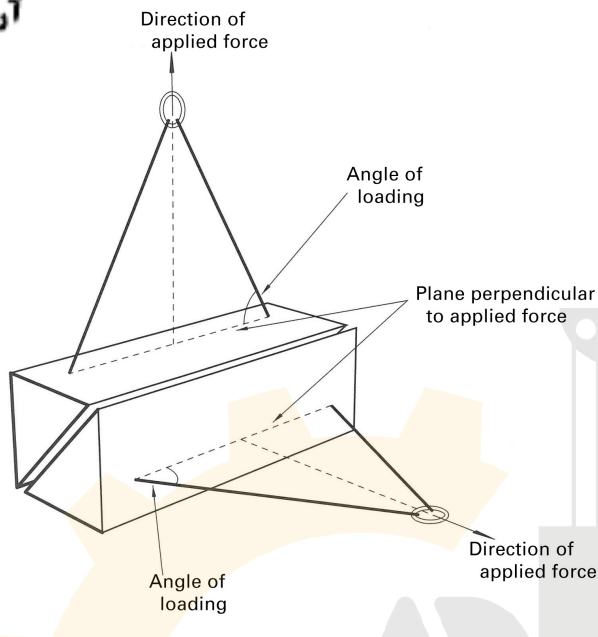
#### 9-7.3.2 Thread

The stitching that is used to secure the cover and tag and to separate load-bearing paths in multipart slings shall be synthetic thread.

#### 9-7.3.3 Coatings

Finishes and coatings shall be compatible with the other components and not impair the performance of the sling.

**Figure 9-7.5-1 Angle of Loading**



### 9-7.3.4 Configurations

(a) Single-leg slings and two-leg, three-leg, and four-leg bridle slings used in straight-line, choker, and basket hitches are covered in this Chapter.

NOTE: A straight-line hitch is commonly referred to as a vertical hitch.

(b) Other configurations may be used. When used, the sling manufacturer or a qualified person shall provide specific data. These slings shall comply with all other requirements of this Chapter.

### SECTION 9-7.4: DESIGN FACTOR

The design factor for HP roundslings shall be a minimum of 5.

### SECTION 9-7.5: RATED LOAD

(a) The sling manufacturer shall establish the sling's rated load.

(b) At a minimum, the rated load shall be based on the following factors:

- (1) component strength
- (2) number of legs
- (3) design factor
- (4) type of hitch
- (5) angle of loading (see [Figure 9-7.5-1](#))
- (6) fabrication efficiency
- (7) pin size limits used for testing as stated by CI 1905

## SECTION 9-7.6: PROOF TEST REQUIREMENTS

### 9-7.6.1 General

(a) Prior to initial use, all HP roundslings incorporating previously used or welded fittings and all repaired slings shall be proof tested by the sling manufacturer or a qualified person.

(b) All other new HP roundslings and fittings are not required to be proof tested unless specified by the purchaser.

### 9-7.6.2 Proof Load Requirements

(a) For single- or multiple-leg slings and endless slings, each leg shall be proof loaded to a minimum of 2 times the single-leg straight-line hitch rated load.

(b) The proof load for fittings attached to single legs shall be a minimum of 2 times the single-leg straight-line hitch rated load.

(c) Master links for two-leg bridle slings shall be proof loaded to a minimum of 4 times the single-leg straight-line hitch rated load.

(d) Master links for three-leg bridle slings shall be proof loaded to a minimum of 6 times the single-leg straight-line hitch rated load.

(e) Master links for four-leg bridle slings shall be proof loaded to a minimum of 8 times the single-leg straight-line hitch rated load.

## SECTION 9-7.7: SLING IDENTIFICATION

### 9-7.7.1 Identification Requirements

Each sling shall be marked to show

- (a) name or trademark of manufacturer, or if repaired, the entity performing repairs
- (b) manufacturer's code or stock number
- (c) rated load for at least one hitch type and the angle upon which it is based
- (d) core yarn — fiber type(s) or blend
- (e) cover material, if different from core material
- (f) number of legs, if more than one

### 9-7.7.2 Initial Sling Identification

Sling identification shall be done by the sling manufacturer.

### 9-7.7.3 Maintenance of Sling Identification

Sling identification should be maintained by the user so as to be legible during the life of the sling.

### 9-7.7.4 Replacement of Sling Identification

Replacement of the sling identification shall be considered a repair as specified in [paras. 9-7.9.6\(a\)](#) and [9-7.9.6\(b\)](#). Additional proof testing is not required.



## 7.8: EFFECTS OF ENVIRONMENT

### Temperature

Some synthetic yarns do not retain their published breaking strength above 140° F (60° C). The HP roundsling manufacturer should be consulted for the temperature range of the roundsling selected for use.

### 9-7.8.2 Chemically Active Environments

The strength of HP roundslings may be degraded by chemically active environments. This includes exposure to chemicals in the form of solids, liquids, gases, vapors, or fumes. The sling manufacturer or qualified person should be consulted before slings are used in chemically active environments.

## SECTION 9-7.9: INSPECTION, REMOVAL, AND REPAIR

### 9-7.9.1 General

All inspections shall be performed by a designated person. Any deficiencies identified shall be examined and a determination made by a qualified person as to whether they constitute a hazard, and if so, what additional steps need to be taken to address the hazard.

### 9-7.9.2 Initial Inspection

Prior to use, all new, altered, modified, or repaired slings shall be inspected to verify compliance with the applicable provisions of this Chapter. Written records are not required for initial inspections.

### 9-7.9.3 Frequent Inspection

(a) A visual inspection for damage shall be performed each day or shift before the sling is used. Slings used in severe or special service should be inspected before each use.

(b) Slings found with conditions such as those listed in [para. 9-7.9.5](#) shall be removed from service. Slings shall not be returned to service until approved by a qualified person.

(c) Written records are not required for frequent inspections.

### 9-7.9.4 Periodic Inspection

(a) A complete inspection of the sling shall be performed. Inspection shall be conducted on the entire length including fittings. Slings found with conditions such as those listed in [para. 9-7.9.5](#) shall be removed from service. Slings shall not be returned to service until approved by a qualified person.

(b) *Periodic Inspection Frequency.* Periodic inspection intervals shall not exceed 1 yr [see (d)]. The frequency of periodic inspections should be based on

- (1) frequency of sling use
- (2) severity of service conditions
- (3) nature of load-handling activities
- (4) experience gained on the service life of slings used in similar circumstances

(c) Guidelines for the time intervals are

- (1) normal service — yearly
- (2) severe service — monthly to quarterly
- (3) special service — as recommended by a qualified person

(d) Periodic inspection is not required for a sling that is in storage or idle. However, if more than 1 yr has passed since the last periodic inspection, the sling shall be inspected in accordance with the requirements listed in (a), (b), and (e), and [para. 9-7.9.5](#) before being placed back into service.

(e) Documentation that the most recent periodic inspection was performed shall be maintained.

(f) Inspection records of individual slings are not required.

### 9-7.9.5 Removal Criteria

An HP roundsling shall be removed from service if any of the following conditions are present:

(a) missing or illegible sling identification (see [Section 9-7.7](#))

(b) acid or caustic burns

(c) evidence of heat damage

(d) holes, tears, cuts, abrasive wear, or snags that expose the core yarns

(e) broken or damaged core yarns

(f) weld splatter that exposes core yarns

(g) knots in the roundsling, except for core yarn knots inside the cover installed by the manufacturer during the fabrication process

(h) fittings that are pitted, corroded, cracked, bent, twisted, gouged, or broken

(i) for hooks, removal criteria as stated in ASME B30.10

(j) for rigging hardware, removal criteria as stated in ASME B30.26

(k) other conditions, including visible damage, that cause doubt as to the continued use of the sling

### 9-7.9.6 Repair

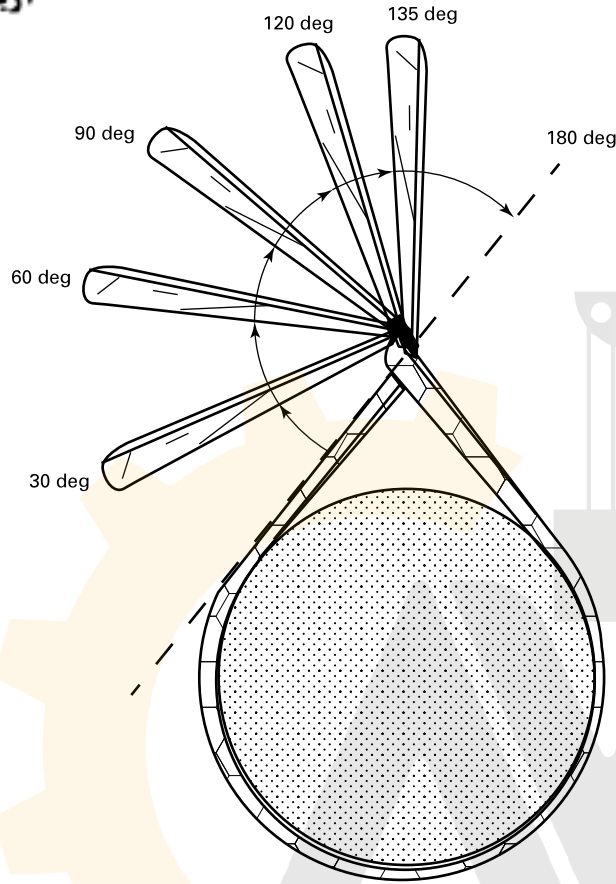
(a) Slings shall be repaired only by the sling manufacturer or a qualified person.

(b) A repaired sling shall be marked to identify the repairing entity per [Section 9-7.7](#).

(c) Components used for sling repair shall comply with the provisions of this Chapter.

(d) Repair of hooks shall be as specified in ASME B30.10. Repair of below-the-hook lifting devices shall be as specified in ASME B30.20. Repair of all other fittings shall be as specified by the sling manufacturer, the fitting manufacturer, or a qualified person.

**-7.10.1-1 Angle of Choke: High Performance Roundslings**



Angle of Choke, deg	Rated Capacity, % [Note (1)]
Over 120	100
90-120	87
60-89	74
30-59	62
0-29	49

NOTE: (1) Percent of sling rated capacity in a choker hitch.

(e) All repairs shall comply with the proof test requirements of Section 9-7.6.

(f) Modifications or alterations to a sling shall conform to all repair provisions of this Chapter.

(g) There shall be no repairs of core yarns.

**SECTION 9-7.10: OPERATING PRACTICES**

**9-7.10.1 Sling Selection**

(a) Slings that appear to be damaged shall not be used unless inspected and accepted as usable under Section 9-7.9.

(b) Slings having suitable characteristics for the type of load, hitch, and environment shall be selected in accordance with the requirements of Sections 9-7.5 and 9-7.8.

(c) The rated load of the sling shall not be exceeded. When using a multiple-leg sling, no leg shall be loaded beyond its single-leg rating.

(d) When the choker hitch rating is not identified on the sling, the choker hitch rating shall be 80% of the sling's straight-line hitch rating unless other ratings are provided by the sling manufacturer or a qualified person.

(e) Rated loads for angles of choke less than 120 deg shall be determined by using the values in Table 9-7.10.1-1, the sling manufacturer, or a qualified person.

(f) For multiple-leg slings used with nonsymmetrical loads, an analysis by a qualified person should be performed to prevent overloading of any leg.

(g) Multiple-leg slings shall be selected according to the sling's rated load based on the specific angle(s) as stated on the sling's identification. The rated load for use at other angles shall be provided by the sling manufacturer or a qualified person.

(h) Slings shall not be used at an angle of loading less than 30 deg except as recommended by the sling manufacturer or a qualified person.

(i) When a sling leg is used as a basket hitch with the lower connector (hook) attaching to the master link (upper connector), the basket hitch rating shall be limited to its single-leg rating, unless the master link is rated to accommodate that configuration.

(j) Fittings shall be of a shape and size to ensure that they are properly seated in the hook, shackle, or other load-handling device. Connection fittings or hardware shall be as recommended by the sling manufacturer or a qualified person.

(k) The rated load of a HP roundslings may need to be reduced depending on the shape and size of an attached fitting or other load-handling device.

(l) HP roundslings shall not be used to support suspended personnel platform.

**9-7.10.2 Cautions to Personnel**

(a) All portions of the human body shall be kept from between the sling and the load, and from between the sling and the hook, shackle, or other load-handling device.

(b) Personnel should not stand in line with or next to the leg(s) of a sling that is under tension.

(c) Personnel shall not stand or pass under a suspended load.

(d) Personnel shall not ride the sling.

**9-7.10.3 Effects of Environment**

(a) Slings should be stored in an area where they will not be subjected to mechanical, chemical, or ultraviolet damage or extreme temperatures (see Section 9-7.8).

(b) Slings incorporating aluminum fittings shall not be used where fumes, vapors, sprays, mists, or liquids of alkalis or acids are present.



### Slings Practices

(a) Slings shall be shortened or adjusted only by methods approved by the sling manufacturer or a qualified person.

(b) Slings shall not be shortened or lengthened by knotting or twisting.

(c) Slings shall be hitched in a manner providing control of the load.

(d) Slings in contact with edges, corners, protrusions, abrasive surfaces, or connecting hardware shall be protected with a material of sufficient strength, thickness, and construction to prevent damage unless the edges are adequately rounded to a radius as recommended by the sling manufacturer or a qualified person.

(e) Shock loading should be avoided.

(f) Loads should not be rested on the sling.

(g) Slings should not be pulled out from under a load if the load is resting on the sling.

(h) Twisting shall be avoided.

(i) During load-handling activities, with or without load, personnel shall be alert for possible snagging.

(j) When using multiple-basket or choker hitches, the load should be rigged to prevent the sling from slipping or sliding along the load.

(k) When lifting with a basket hitch, the legs of the sling should contain or support the load from the sides, above the center of gravity, so that the load remains under control.

(l) Slings should not be dragged on the floor or over an abrasive surface.

(m) In a choker hitch, the choke point should only be on the sling body, not on a cover splice or fitting.

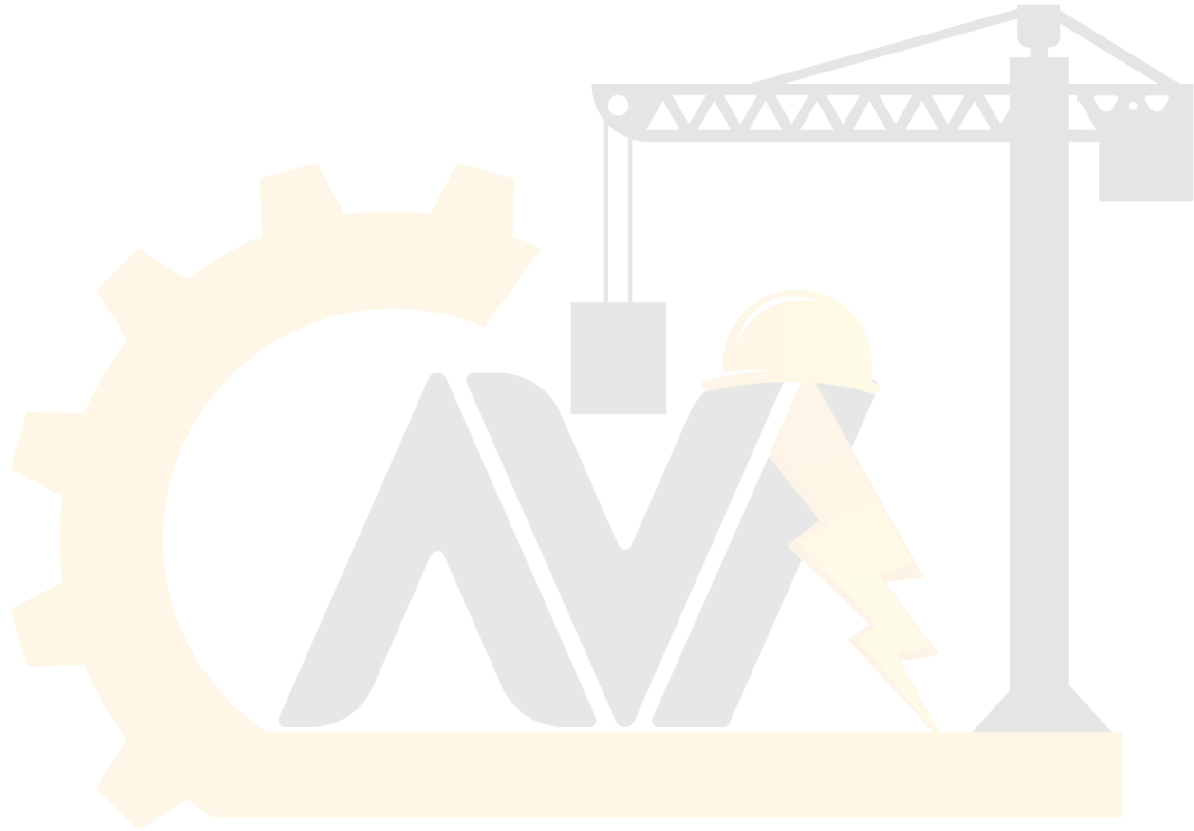
(n) Slings should not be constricted, bunched, or pinched by the load, hook, or any fitting.

(o) The load applied to the hook should be centered in the base (bowl) of the hook to prevent point loading on the hook, unless the hook is designed for point loading.

# آريا ايمن آوات



30.9-2018



آریا ایمن آوات

ISBN 978-0-7918-7202-4



9 780791 872024



J 0 9 2 1 8