

Cranes — Safety — Tower cranes

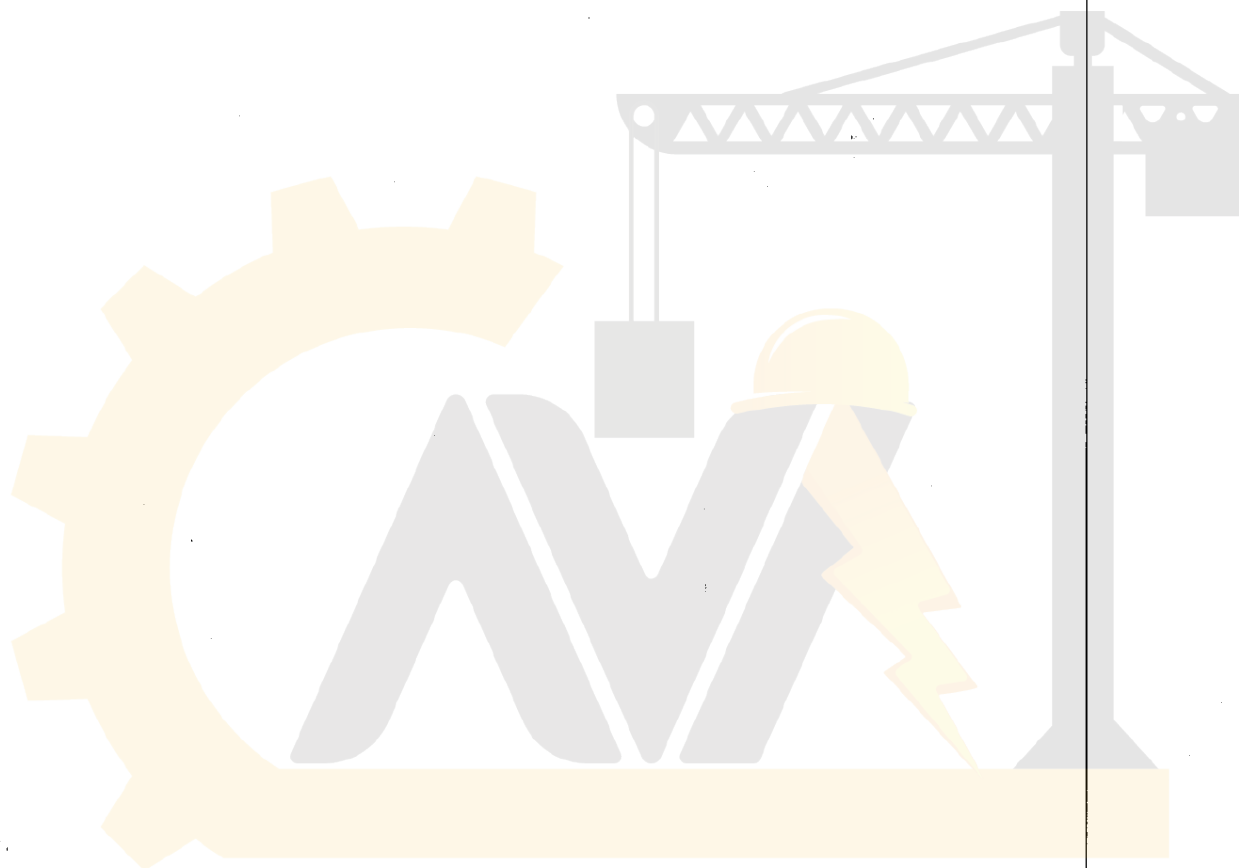

آریا ایمن آوات

The European Standard EN 14439:2006 has the status of a
British Standard

ICS 53.020.20

National foreword

This British Standard was published by BSI. It is the UK implementation of EN 14439:2006.

The UK participation in its preparation was entrusted by Technical Committee MHE/3, Cranes and derricks, to Subcommittee MHE/3/5, Mobile cranes.

A list of organizations represented on MHE/3/5 can be obtained on request to its secretary.

This publication does not purport to include all the necessary provisions of a contract. Users are responsible for its correct application.

Compliance with a British Standard cannot confer immunity from legal obligations.

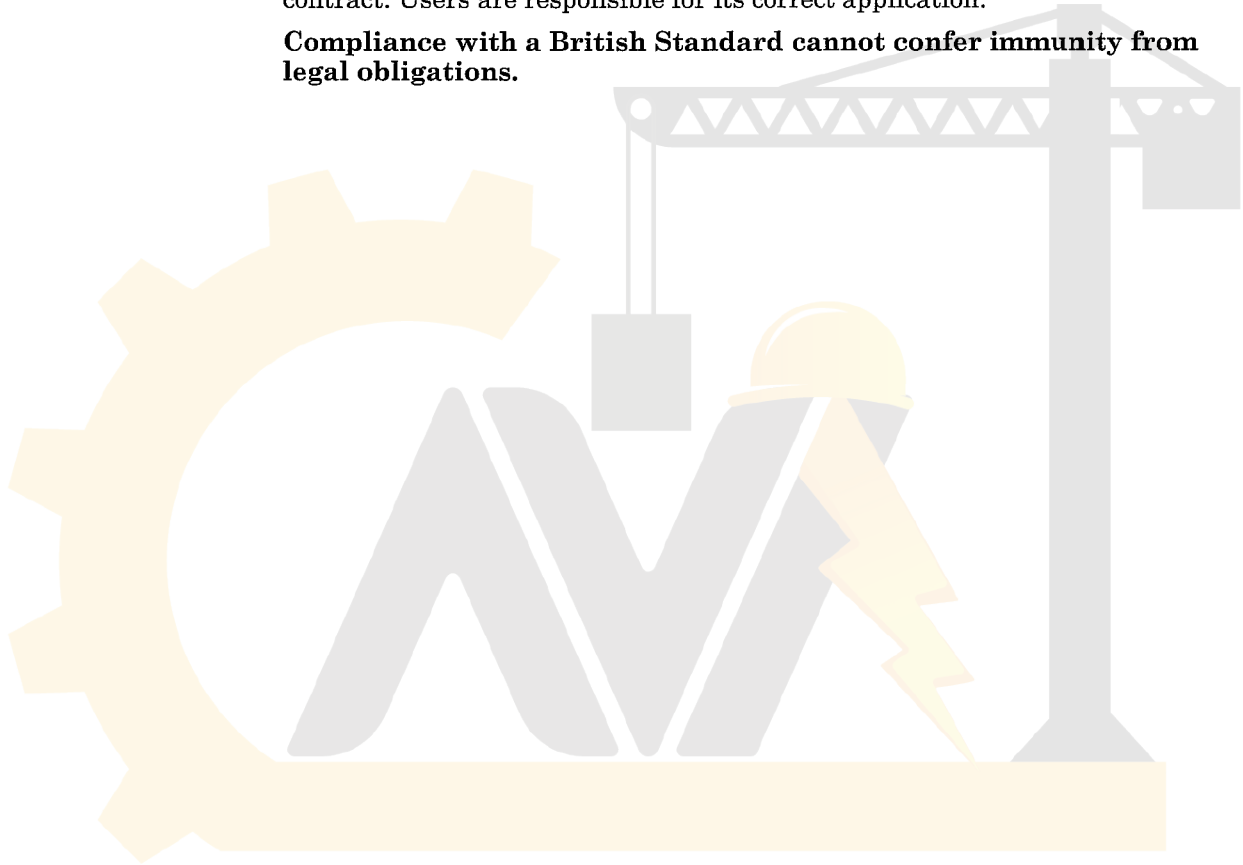

آریا ایمن آوات

This British Standard was published under the authority of the Standards Policy and Strategy Committee on 31 January 2007

Amendments issued since publication

Amd. No.	Date	Comments

© BSI 2007

ISBN 978-0-580-49963-0

ICS 53.020.20

English Version

Cranes - Safety - Tower cranes

Appareils de levage à charge suspendue - Sécurité - Grues
à tour

Krane - Sicherheit - Turmdrehkrane

This European Standard was approved by CEN on 21 October 2006.

CEN members are bound to comply with the CEN/CENELEC Internal Regulations which stipulate the conditions for giving this European Standard the status of a national standard without any alteration. Up-to-date lists and bibliographical references concerning such national standards may be obtained on application to the Central Secretariat or to any CEN member.

This European Standard exists in three official versions (English, French, German). A version in any other language made by translation under the responsibility of a CEN member into its own language and notified to the Central Secretariat has the same status as the official versions.

CEN members are the national standards bodies of Austria, Belgium, Cyprus, Czech Republic, Denmark, Estonia, Finland, France, Germany, Greece, Hungary, Iceland, Ireland, Italy, Latvia, Lithuania, Luxembourg, Malta, Netherlands, Norway, Poland, Portugal, Romania, Slovakia, Slovenia, Spain, Sweden, Switzerland and United Kingdom.

آریا ایمن آوات



EUROPEAN COMMITTEE FOR STANDARDIZATION
COMITÉ EUROPÉEN DE NORMALISATION
EUROPÄISCHES KOMITEE FÜR NORMUNG

Management Centre: rue de Stassart, 36 B-1050 Brussels

Contents

Page

Foreword	3
Introduction	4
1 Scope.....	5
2 Normative references	5
3 Terms and definitions	6
4 List of significant hazards	7
5 Safety requirements and/or protective measures	10
5.1 General	10
5.2 Design requirements on the load bearing structure	10
5.3 Design requirements for equipment	11
5.4 Design requirements for health and safety	12
5.5 Noise reduction	20
6 Verification of the safety requirements and/or protective measures	20
6.1 General	20
6.2 Method of verification	20
6.3 Fitness for purpose.....	21
6.4 Noise measurement	22
7 Information for use.....	22
7.1 General	22
7.2 Instructions handbook	22
7.3 Marking.....	24
Annex A (normative) Stability requirements	26
Annex B (informative) Requirements for the provision of anti-collision on tower crane	27
Annex C (normative) Outside indicators on the crane	29
Annex D (normative) Verification of the safety requirements and/or protective measures	30
Annex E (normative) Noise test code	33
Annex F (informative) Marking - Example of layout.....	38
Annex G (informative) Selection of a suitable set of crane standards for a given application	43
Annex ZA (informative) Relationship between this European Standard and the Essential Requirements of EU Directive 98/37/EC	44
Bibliography	45

Foreword

This document (EN 14439:2006) has been prepared by Technical Committee CEN/TC 147 "Cranes - Safety", the secretariat of which is held by BSI.

This European Standard shall be given the status of a national standard, either by publication of an identical text or by endorsement, at the latest by June 2007, and conflicting national standards shall be withdrawn at the latest by June 2007

This document has been prepared under a mandate given to CEN by the European Commission and the European Free Trade Association, and supports essential requirements of EU Directive(s).

For relationship with EU Directive(s), see informative Annex ZA, which is an integral part of this document.

To select a suitable set of crane standards for a given application see Annex G.

NOTE Some of the standards listed are in preparation.

According to the CEN/CENELEC Internal Regulations, the national standards organizations of the following countries are bound to implement this European Standard: Austria, Belgium, Cyprus, Czech Republic, Denmark, Estonia, Finland, France, Germany, Greece, Hungary, Iceland, Ireland, Italy, Latvia, Lithuania, Luxembourg, Malta, Netherlands, Norway, Poland, Portugal, Romania, Slovakia, Slovenia, Spain, Sweden, Switzerland and United Kingdom.

آریا ایمن آوات

Introduction

This European Standard is a harmonised European Standard to provide one means for tower cranes to conform with the relevant Essential Health and Safety Requirements of the Machinery Directive 98/37/EC modified.

This European Standard is a type C standard as stated in EN ISO 12100-1:2003.

The machinery concerned and the extent to which hazards, hazardous situations and hazardous events are covered are indicated in the scope of this European Standard.

When provisions of this type C standard are different from those which are stated in type A or B standards, the provisions of this type C standard take precedence over the provisions of the other standards, for cranes that have been designed and built according to the provisions of this type C standard.

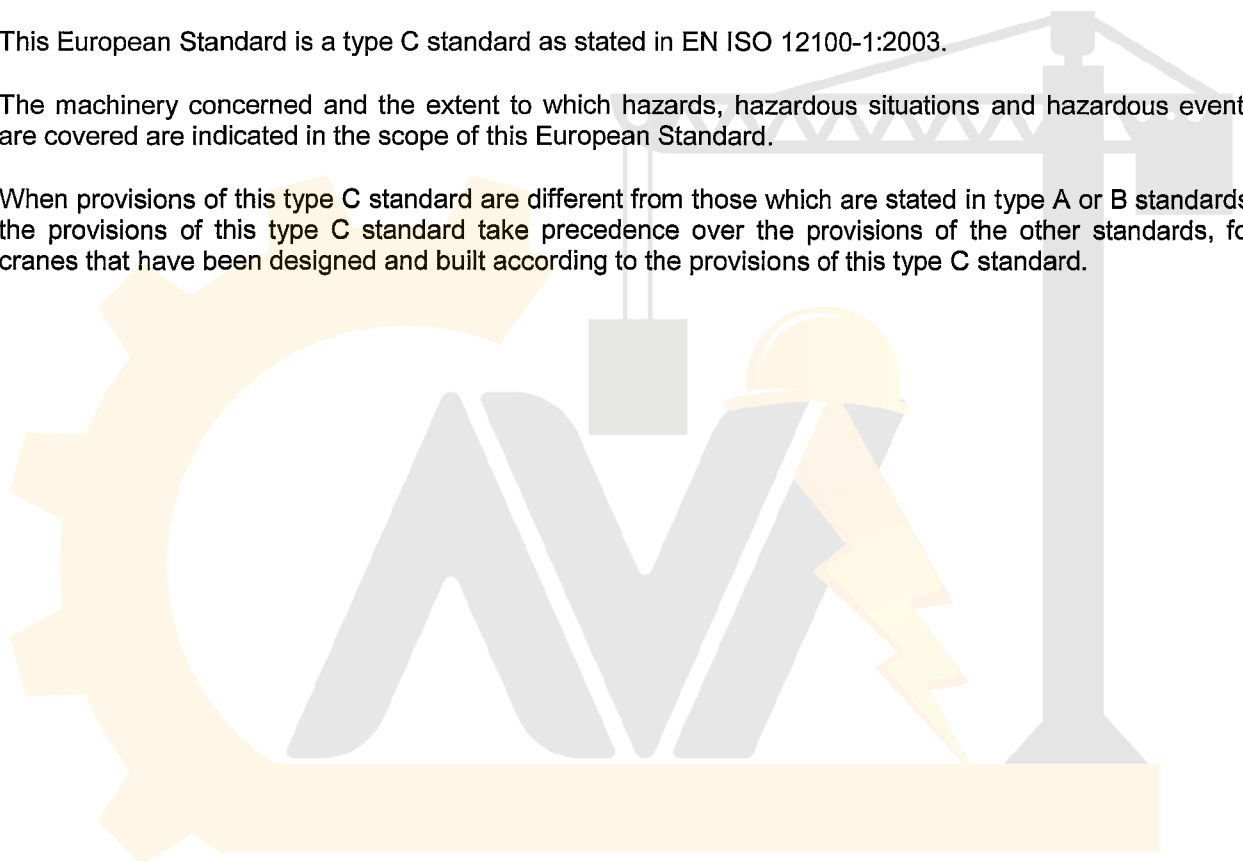

آریا ایمن آوات

1 Scope

This European Standard specifies safety requirements for tower cranes.

This European Standard applies to tower cranes for construction work, which are either erected by parts or self erecting cranes.

This European Standard is not applicable to mobile cranes, mobile harbour cranes, crawler cranes, slewing jib cranes, bridge and gantry cranes, offshore cranes, floating cranes, loader cranes, hand operated cranes or railway cranes.

This European Standard deals with all significant hazards, hazardous situations and events relevant to tower cranes, when used as intended and under conditions foreseen by the manufacturer. This European Standard specifies the appropriate technical measures to eliminate or reduce risks arising from the significant hazards (see Clause 4).

The significant hazards covered by this European Standard are identified in Clause 4.

This European Standard does not cover hazards related to:

- the lifting of persons by the tower crane itself;
- the climbing system.

The requirements related to Electromagnetic compatibility (EMC), the specific hazards due to external influence on electrical equipment, potentially explosive atmospheres and ionising radiation are not covered by this European Standard.

This European Standard is not applicable to tower cranes which are manufactured before the date of publication by CEN of this European Standard.

2 Normative references

The following referenced documents are indispensable for the application of this document. For dated references, only the edition cited applies. For undated references, the latest edition of the referenced document (including any amendments) applies.

EN 954-1:1996, *Safety of machinery — Safety-related parts of control systems — Part 1: General principles for design*

EN 12077-2:1998, *Cranes safety — Requirements for health and safety — Part 2: Limiting and indicating devices*

EN 12644-1:2001, *Cranes — Information for use and testing — Part 1: Instructions*

EN 13135-1:2003, *Cranes — Safety — Design — Requirements for equipment — Part 1: Electrotechnical equipment*

EN 13135-2:2004, *Cranes — Equipment — Part 2: Non-electrotechnical equipment*

EN 13557:2003, *Cranes — Controls and control stations*

EN 13586:2004, *Cranes — Access*

EN 14439:2006 (E)

EN 60204-32, *Safety of machinery — Electrical equipment of machines — Part 32: Requirements for hoisting machines (IEC 60204-32:1998)*

EN ISO 3744:1995, *Acoustics — Determination of sound power levels of noise sources using sound pressure — Engineering method in an essentially free field over a reflecting plane (ISO 3744:1994)*

EN ISO 4871, *Acoustics — Declaration and verification of noise emission values of machinery and equipment (ISO 4871:1996)*

EN ISO 11201:1995, *Acoustics — Noise emitted by machinery and equipment — Measurement of emission sound pressure levels at a work station and at other specified positions — Engineering method in an essentially free field over a reflecting plane (ISO 11201:1995)*

EN ISO 11203, *Acoustics — Noise emitted by machinery and equipment — Determination of emission sound pressure levels at a work station and at other specified positions from the sound power level (ISO 11203:1995)*

EN ISO 12100-1:2003, *Safety of machinery — Basic concepts, general principles for design — Part 1: Basic terminology, methodology (ISO 12100-1:2003)*

EN ISO 12100-2:2003, *Safety of machinery — Basic concepts, general principles for design — Part 2: Technical principles (ISO 12100-2:2003)*

ISO 3864 (all parts), *Graphical symbols — Safety colours and safety signs*

ISO 4306-1:1990, *Cranes — Vocabulary — Part 1: General*

ISO 4306-3:2003, *Cranes — Vocabulary — Part 3: Tower cranes*

ISO 7752-3, *Cranes — Controls — Layout and characteristics — Part 3: Tower cranes*

ISO 8566-3, *Cranes — Cabins — Part 3: Tower cranes*

ISO 13200, *Cranes — Safety signs and hazard pictorials — General principles*

DIN 15018-1, *Cranes — Steel structures — Verification and analyses*

DIN 15018-2, *Cranes — Steel structures — Principles of design and construction*

DIN 15019-1, *Cranes — Stability for all cranes except non-rail mounted mobile cranes and except floating cranes*

FEM 1.001 (all parts), *Rules for the design of hoisting appliances*

FEM 1.003:1995, *Tower cranes — Graphical symbols*

FEM 1.005:2003, *Recommendation for the calculation of tower crane structures in out-of service conditions*

3 Terms and definitions

For the purposes of this document, the terms and definitions given in EN ISO 12100-1:2003, ISO 4306-1:1990 and ISO 4306-3:2003 and the following apply.

NOTE Definitions are in alphabetical order for the English version only.

3.1**rated capacity**

load, having mass m_{NL} , which is lifted by the crane and suspended from the fixed load-lifting attachment(s). Mass m_{NL} is the sum of the pay load m_{PL} and the non-fixed load-lifting attachment(s) m_{NA} :

$$m_{NL} = m_{PL} + m_{NA}$$

The maximum net load that the crane is designed to lift for a given crane configuration and load location during normal operation.

3.2**tower crane**

slewing jib crane with the jib located at the top of a tower which stays approximately vertical in the working position. This power-driven appliance is equipped with means for raising and lowering suspended loads and for the movement of such loads by changing the radius, slewing and/or travelling of the complete appliance.

NOTE 1 Certain appliances perform several, but not necessarily all of these movements.

NOTE 2 The appliance can be installed in a fixed position or equipped with means for displacement or climbing.

4 List of significant hazards

Table 1 contains all the significant hazards, hazardous situations and events, as far as they are dealt with in this European Standard, identified by risk assessment as significant for this type of machinery and which require action to eliminate or reduce the risk. It also contains the corresponding cross-references to EN ISO 12100, and the relevant clauses in this European Standard that are necessary to reduce or eliminate the risks associated with those hazards.

Table 1 — List of significant hazards and associated requirements

N°	Hazards	Relevant clause(s) in this European Standard
Hazards, hazardous situations and hazardous event		
1	Mechanical hazards due to machine parts or workpieces, e.g.	
	– Shape	5.4.1
	– Inadequacy of mechanical strength	5.2, 5.3.2
1.1	Crushing hazard	5.4.3, 5.4.4, 5.4.4.2
1.2	Shearing hazard	5.4.3
1.3	Cutting or severing hazard	5.4.3
1.4	Entanglement hazard	5.4.3, 5.4.3.1
1.5	Drawing-in or trapping hazard	5.4.3
1.6	Impact hazard	5.4.2, 5.4.1.8, 5.4.2.9, 5.4.3
1.9	High pressure fluid injection or ejection hazard (on cranes with hydraulic)	5.3.2
2	Electrical hazards due to:	
2.1	Contact of persons with live parts (direct contact)	5.3.1
2.2	Contact of persons with parts which have become live under faulty conditions (indirect contact)	5.3.1

N°	Hazards	Relevant clause(s) in this European Standard
2.3	Approach to live parts under high voltage	5.3.1
3	Thermal hazards, resulting in:	
3.1	Burns, scalds and other injuries by a possible contact of persons with objects or materials with an extreme high or low temperature, by flames or explosions and also by the radiation of heat sources	5.4.1
3.2	Damage to health by hot or cold working environment	5.4.1, 5.4.1.8
4	Hazards generated by noise	5.5, 7.2.5, Annex E
4.1	Hearing loss	5.5, 7.2.5, Annex E
4.2	Interference with speech communication	5.5, 7.2.5, Annex E
7	Hazards generated by materials and substances (and their constituent elements) processed or used by the machinery	
7.2	Fire or explosion hazard	5.4.1
8	Hazards generated by neglecting ergonomic principles in machinery design as, e.g. hazards from:	
8.1	Unhealthy postures or excessive effort	5.4.4.4
8.2	Inadequate consideration of hand-arm foot-leg anatomy	5.4.1, 5.4.1.4
8.3	Neglected use of personal protection equipment	5.4.4, 5.4.4.5.1
8.4	Inadequate local lighting	5.4.1, 5.4.5
8.6	Human error, human behaviour	5.4.1, 5.4.1.2, 5.4.1.3, 5.4.2.5.1, 5.4.2.5.2, 5.4.2.6, 5.4.6
8.7	Inadequate design, location or identification of manual controls	5.4.1, 5.4.1.4
8.8	Inadequate design or location of visual display unit	5.4.1, 5.4.1.2
10	Unexpected start-up, unexpected overrun/overspeed (or any similar malfunction) from:	
10.1	Failure/Disorder of the control system	5.4.1, 5.4.1.9, 5.4.2, 5.4.2.2
10.4	Other external influences (gravity, wind, etc)	5.2.1, 5.4.2.6, 5.4.2.10, 7.2.6
10.5	Errors in software	5.3.1
10.6	Errors made by the operator (due to mismatch of machinery with human characteristics and abilities)	5.4.1, 5.4.1.2, 5.4.1.3, 5.4.2.5.1, 5.4.2.5.2, 5.4.2.6, 5.4.6
13	Failure of the power supply	5.3.1
14	Failure of the control circuit	5.3.1
16	Break-up during operation	5.2, 5.3.2, 5.4.2.8, 5.4.3.2
17	Falling or ejected objects or fluids	5.4.3.2
18	Loss of stability/overturning of machinery	5.2, 5.4.2, 5.4.2.3, 5.4.2.4, 5.4.2.7, 5.4.2.8
19	Slip, trip and fall of persons (related to machinery)	5.4.4, 5.4.4.3, 5.4.4.5
Additional hazards, hazardous situations and hazardous event due to mobility		
21	Linked to the work position (including driving station) on the machine	

N°	Hazards	Relevant clause(s) in this European Standard
21.1	Fall of persons during access to (or at/from) the work position	5.4.4, 5.4.4.3
21.3	Fire (flammability of cab, lack of extinguishing means)	5.4.1
21.4	Mechanical hazards at the work position: d) Break-up of parts rotating at high speed	5.4.3.1, 5.4.3.2, 5.4.4.2
21.5	Insufficient visibility from the work positions	5.4.1, 5.4.1.5
21.6	Inadequate lighting	5.4.1
21.7	Inadequate seating	5.4.1
21.8	Noise at the work position	5.5, 7.2.5
21.10	Insufficient means for evacuation/emergency exit	5.4.1, 5.4.4
22	Due to the control system	
22.1	Inadequate location of manual controls	5.3.1, 5.4.1, 5.4.1.3
22.2	Inadequate design of manual controls and their mode of operation	5.3.1, 5.4.1, 5.4.1.2
23	From handling of the Machine (lack of stability)	7.2, 7.2.4
25	From/to third persons	
25.2	Drift of part away from its stopping position	5.3.1, 5.3.2, 5.4.2
25.3	Lack or inadequacy of visual or acoustic warning means	7.3.2, 5.4.6
Additional hazards, hazardous situations and hazardous event due to lifting		
27	Mechanical hazard and hazardous events	
27.1	From load falls, collisions machine tipping caused by:	
27.1.1	Lack of stability	5.2
27.1.4	Unexpected/unintended movement of the load	5.3.1, 5.3.2, 5.4.2
27.1.6	Collision of more the one machine	5.4.2.8
27.2	From access of persons to load support	7.2.6
27.3	From derailment	5.3.2
27.4	From insufficient mechanical strength of parts	5.2, 5.3.2
27.5	From inadequate design of pulleys, drums	5.3.2
27.6	From inadequate selection of chains, ropes lifting and accessories and their inadequate integration into the machine	5.3.2.3
27.7	From lowering of load under control of friction brake	5.3.2
27.8	From abnormal conditions of assembly/testing/use/maintenance	6.3
28	Electrical hazards	
28.1	From lightning	5.3.1
29	Hazards generated by neglecting ergonomic principles	
29.1	Insufficient visibility from the driving position	5.4.1, 5.4.1.5

5 Safety requirements and/or protective measures

5.1 General

Tower cranes shall conform with the safety requirements and/or protective measures of this clause. In addition, the tower crane shall be designed according to the principles of EN ISO 12100 for hazards relevant but not significant, which are not dealt with by this European Standard.

5.2 Design requirements on the load bearing structure

5.2.1 General

Calculation (proof of strength and stability proof) shall be done using:

- the current standards (FEM 1.001 or DIN 15018-1, DIN 15018-2 and DIN 15019-1);
- Annex A for stability during erection or dismantling;
- FEM 1.005 for out of service stability.

NOTE EN 13001 can be used on trial. When the complete set of EN 13001 will be published and experience is available then WGP2 will revise EN 14439 to introduce its reference including the necessary adaptation for tower cranes.

5.2.2 Load effects

5.2.2.1 Load effects acting on tower crane during the crane's life may be determined by calculation or by experiment and shall reflect realistic unfavourable operating conditions and sequences of actions by the crane driver.

5.2.2.2 The loads, moments (bending and/or torsion) etc. may be derived from a rigid body kinetic model of the crane and the load models.

NOTE 1 Whilst the resulting variations of rotation or travel speeds are in relative good conformity with reality, the variations and instantaneous values of accelerations and resulting inner forces represent only mean values of the real process. For this reason sudden alterations of this mean values have to be amplified by dynamic factors to estimate the real values, corresponding to the data as defined under standards given in 5.2.1.

NOTE 2 Structural deformations are to be allowed for if they result in significant increases in stresses. Calculations shall be based on the assumption of a deformed system in a state of equilibrium (second order theory). The calculation may be made with an appropriate and recognised method e.g. FEM 1.001:1998, 3.5 and 9.11.

5.2.2.3 The group classification of a tower crane shall be in accordance with FEM 1.001, booklet 2:

- crane at least A3;
- jib at least E2.

When calculation is done using other standards (see 5.2.1), an equivalent classification is required.

5.2.2.4 Wind forces shall be determined with an appropriate and recognised method e.g. F.E.M. 1.001.

5.2.2.5 For travel gears of tower cranes, a verification of the energy absorption capacity of the buffers and of the effect of the buffer forces on the supporting structure may be dispensed with, on condition that the rated travelling speed is less than 40 m/min and that limit switches are installed in addition to buffer stops.

5.3 Design requirements for equipment

5.3.1 Electrotechnical equipment

The design requirements for electrotechnical equipment shall conform to EN 60204-32 and EN 13135-1.

5.3.2 Non-electrotechnical equipment: Design and selection of components and equipment

5.3.2.1 General

The design requirements for non-electrotechnical equipment shall conform to EN 13135-2.

5.3.2.2 Mechanisms

The mechanism group classifications in accordance with FEM 1.001:1998, booklet 2, Table T.2.1.3.4 shall be at least:

- hoisting winch or luffing gear M4;
- slewing gear M5;
- trolley travelling mechanism M3;
- travelling gear M3;

NOTE The mechanism used to change occasionally the position of the crane may be defined in group M2.

- Auxiliary winch only used for mounting and maintenance operations M1.

The mechanisms shall be calculated in accordance with FEM 1.001, booklet 4.

5.3.2.3 Ropes

Selection and calculation of running and stationary ropes shall be carried out from the maximum tensile force in the rope in accordance with FEM 1.001, booklet 4. The influences of dynamic effects and friction losses have to be considered.

The mechanism group classification in accordance with FEM 1.001, booklet 2 shall be at least:

- lifting or luffing ropes M4;
- trolley travel ropes M4, and M3 when rope braking is monitored (see 5.4.2.7);
- erection ropes M3;
- stationary ropes M3.

5.3.2.4 Rail wheels

Rail wheels shall be determined with an appropriate and recognised method, e.g. with FEM 1.001, booklets 4 and 9.

5.4 Design requirements for health and safety

5.4.1 Controls and control stations

5.4.1.1 General

The design requirements for controls and control stations shall conform to EN 13557 with the changes according to Table 2.

Table 2 — Design requirements for controls and control stations

Subclause in EN 13557:2003	Topic	Change	Subclause in this European Standard
5.1.2	Symbols on controls for tower cranes	completed by	5.4.1.2
5.1.3	Arrangement of the controls	completed by	5.4.1.3
5.1.6	Unintended movement of a crane	No modification EN 13557:2003 applies	
5.2.1.2	Control station dimensions	completed by	5.4.1.4
5.2.2.2.6	Means to clear external surfaces of windows	completed by	5.4.1.5
5.2.2.3.1.4	Effective door aperture	No modification EN 13557:2003 applies	
5.2.2.3.1.5	Effective hatch aperture	completed by	5.4.1.6
5.2.2.3.1.6	Dimensions of the hatch in the floor	completed by	5.4.1.7
5.2.2.6.2	Cabin climate	completed by	5.4.1.8
C.3.1	Category according to EN 954-1 for cableless controls	No modification (No particular category for tower cranes)	
C.3.2	Recommended delay to stop all crane movements, when no valid frame has been correctly received	completed by	5.4.1.9

NOTE When EN 13557 requests for specific requirements from particular cranes types standards, the answer is given even there is no modification.

5.4.1.2 For tower cranes the symbols according to FEM 1.003 are recommended.

5.4.1.3 The arrangement of the controls shall be in accordance with ISO 7752-3.

5.4.1.4 Control station dimensions shall conform to ISO 8566-3.

5.4.1.5 On tower cranes, windscreens wiper and washers shall be provided on the front cabin window.

5.4.1.6 The minimum dimensions for effective hatch apertures shall be 0,55 m × 0,55 m.

On self erecting cranes the hatch:

- can be under the driver seat, only if a other solution isn't possible;

— can have its dimensions reduced to 0,50 m × 0,50 m when necessary due to the size of the crane.

5.4.1.7 For self-erecting tower cranes, the dimensions of the standing area shall be 0,2 m × 0,6 m minimum.

5.4.1.8 It shall be possible to obtain an operative temperature of more than 18 °C with a out temperature from –10 °C within 30 min.

The cabin shall be in a condition to protect the driver from draught when the door and windows are closed.

The cabin shall be equipped with a system, who allowed the entrance from outside air.

5.4.1.9 The required time in C.3.2 of EN 13557:2003 is 1 s.

5.4.2 Limiting and indicating devices

5.4.2.1 General

The design requirements for limiting and indicating devices shall conform to EN 12077-2 with the changes according to Table 3.

Table 3 — Design requirement for limiting and indicating devices

Subclause in EN 12077-2: 1998	Topic	Change	Subclause in this European Standard
5.2.9	Categories in accordance with EN 954-1:1996	replaced by	5.4.2.2
5.3	Rated capacity limiters and indicators	completed by	5.4.2.3
5.4.1.2	Rated capacity limiters - Tolerances	completed by	5.4.2.4
5.4.2.1	Rated capacity limiters - Operating requirements	completed by	5.4.2.4
5.5.1	Rated capacity indicators - Operating requirements	completed by	5.4.2.5.1
5.6.1	Motions limiters	completed by	5.4.2.6; 5.4.2.7; 5.4.2.8; 5.4.2.9
5.7	Indicators	completed by	5.4.2.4.2; 5.4.2.10

5.4.2.2 For limiters at least the following categories in accordance with EN 954-1:1996, Clause 6 shall be used:

- a) For control circuits built with electromechanical components: category 1;
- b) For control circuits built with electronic components: category 2.

5.4.2.3 A rated capacity limiter/indicator shall operate according the installed jib length.

5.4.2.4 Rated capacity limiters - Operating requirements

5.4.2.4.1 General

The rated capacity limiter shall operate at a load as close as possible to the rated capacity to prevent the crane operator from handling load greater than the rated capacity.

When the rated capacity limiter operates due to a load exceeding the rated capacity or due to a load moment exceeding the rated capacity the limiter shall operate at a load or a load moment greater or equal to 1,1 times the rated capacity under normal conditions of use.

NOTE The limitation of the load moment is ensured with at least 2 limiters, one operating on the rated capacity, the other on the radius.

The procedure to set up the load moment limiters of the crane shall be described in the instruction handbook (Clause 7).

5.4.2.4.2 Overriding

Provision for overriding the rated capacity limiter shall not be provided.

Use of the alternative setting of the standard rated capacity limiter foreseen by the manufacturer is not considered as overriding if the crane is kept within its designed and stated capacity as given in the instruction handbook.

5.4.2.5 Rated capacity indicators

5.4.2.5.1 The rated capacity indicator shall give a warning of the approach to the rated capacity at a value between 90 % and 95 % of the rated capacity.

On tower cranes provided with remote controls, this rated capacity indicator may be installed on the crane. It shall be a visual warning signal defined in 5.4.6.2.

5.4.2.5.2 The tower cranes shall be provided with indicators as shown in the Table 4. The choice is given between the solutions marked with a cross. Other means providing equivalent information can also be used.

NOTE Indicators for the actual radius and the actual load give a more precise indication than the plates on the jib.

آریا ایمن آوات

Table 4 — Indicators

	Horizontal jib non telescopic		Telescopic jib		Folding jib		Luffing jib	
	Tower cranes assembled from components parts	Self erecting tower cranes	Tower cranes assembled from components parts	Self erecting tower cranes	Tower cranes assembled from components parts	Self erecting tower cranes	Tower cranes assembled from components parts	Self erecting tower cranes
Indicators for the actual radius and the actual load	X	X	X	X	X	X	X	X
Plates on the jib The load ratio between two succeeding steps is not more than 1,5 including the value of the maximum load at the maximum authorised radius and the value of the load at the maximum radius	X	X						
Plates on the jib indicating the value of the maximum load at the maximum authorised radius and the value of the load at the maximum radius				X		X		X

5.4.2.6 Motion limiters

5.4.2.6.1 General

The motion limiters shall be provided according to Table 5.

5.4.2.6.2 Overriding

When it is necessary to override motion limiters in normal operation (e.g. change of the falls number, storage of the trolley) provision may be at the control station.

The overriding devices shall be hold-to-run types and the crane components and the crane's stability shall not be endangered.

5.4.2.7 For trolley drives on horizontal jib using ropes the breakage of a trolley travelling rope shall initiate the stop of the trolley.

Table 5 — Motion limiter

a) Hoisting limiter	YES
b) Lowering limiter	YES
c) Slack rope limiter	NO
d) Slewing limiter	No if power supply via slipping assembly
e) Travelling limiter	YES
f) Derricking limiter	YES
g) Telescoping limiter	NO if erection work - YES if working condition
h) Control station position limiter	YES, if the control station is moved during service
i) Working space limiter ^a	Not mandatory, at the request of the user according the risk analysis of the job site
j) Anti-collision device	Not mandatory, at the request of the user
k) Trolleying limiter	YES
l) A-frame position limiter	YES

^a Working space limiter and crane being interdependent, the power supply shall be such that when the crane is "on", the working space limiter is automatically "on".

5.4.2.8 Requirements for the provision of anti-collision device on tower crane

Each tower crane shall be capable of being equipped with anti-collision device. This device shall stop motions to avoid entering in a forbidden area and allow the reverse movement.

Crane manufacturer shall determine the connection points necessary for the action of the device on the movement or function of the crane.

The choice of these connection points and the given orders shall be such that the device actions are compatible with the normal use of the crane mechanisms (decelerating before stopping high inertia motions, mechanical brakes application).

All connection points necessary for the installation of the device on the crane motion, shall be assembled in a specific collector or on a dedicated cable.

This specific collector or dedicated cable shall be installed on all cranes except on self erecting cranes.

NOTE Annex B provides some guidance for the anti-collision device.

5.4.2.9 Requirements for the provision of working space limiter on tower crane

Each tower crane shall be capable of being equipped with working space limiter. This device shall stop motions to avoid entering in a forbidden area and allow the reverse movement.

NOTE Annex B can be used also to provide some guidance for working space limiter.

5.4.2.10 Anemometer

Tower cranes shall be provided with an anemometer except for self erecting cranes with a height under hook of less than 30 m measured with a horizontal jib.

When an anemometer is installed, the information about the wind level shall be given to the driver and could be achieved by different means (speed value, visual signal, audible signal). In any case the driver shall have a warning level and an alarm level. When visual signals are used for indicator, see Annex C for the choice of the colour.

5.4.3 Guarding

5.4.3.1 Guards for moving parts

During the access to the control station, moving parts shall be guarded by safety distances as defined in EN 294 or by provision of removable or fixed guards.

The guards which may be used as walkways or work platform shall be designed for this use, see EN 13586.

5.4.3.2 Prevention of crane components from falling

Crane parts such as gears, pulleys, trolley wheels, covers and boxes shall be designed, assembled and fixed in such a way to prevent them from falling during normal operation.

Covers, guards and access closures shall be fitted with hinges or other means to restrain them from falling.

The trolleys shall be design such as the wheels should not slip out from the railway in case of rupture of the axis; furthermore the falling of the trolley shall not be possible.

The output gears of the slewing gears shall be provided with covers or any other device avoiding their falling in case of rupture.

5.4.4 Access

5.4.4.1 General

The design requirements for access shall conform to EN 13586 with the changes as shown in Table 6.

Means of access can include a passing through the structure of the crane even if the dimension does not comply with EN 13586.

Table 6 — Design requirements for access

Clause in EN 13586:2004	Topic	Change	In this European Standard
6.2.8	Crushing hazard between moving parts	completed by	5.4.4.2
6.4.1	Rung ladders	completed by	5.4.4.3
6.6	Manholes	completed by	5.4.4.4

5.4.4.2 Crushing hazard between moving parts

Where persons could be present between moving parts a safety distance of at least 0,5 m shall be observed. Where such a distance cannot be obtained, guards (when possible) and warning notices shall be fitted.

5.4.4.3 For all types of tower cranes, the first flight of ladder may be of 10 m maximum.

Furthermore for self erecting cranes:

- flights of type 1 ladders shall be positioned to prevent persons falling more than 10 m maximum;
- Type 1 ladders shall have rest platforms at least every 10 m;
- evacuation of an elevating control station in the event of power failure or suchlike shall be possible by alternative means of egress. When a ladder is used for this purpose, the dimensions defined in EN 13586 are not applicable. The dimension m (clear width, Table 4) may be reduced to 0,2 m and the dimension d (distance between the centre line of the rung and vertical surface) may be reduced to 0,1 m allowing the use of the rung at least by one foot.

5.4.4.4 Hatch apertures

If the crane construction does not allow larger dimensions, for type 2 access according EN 13586 the minimum dimensions for effective hatch apertures shall be 0,5 m by 0,4 m.

5.4.4.5 Access provided in a horizontal jib

5.4.4.5.1 General

If it is not possible to lower the jib to the ground to carry out a visual inspection of the jib, a basket fixed to the trolley shall be provided. In addition a walkway with:

- side protection, or
- personal protective device against the falls

shall be fixed along the jib to reach the mechanism(s).

When during erection/dismantling, repair or the maintenance the basket cannot be used, the use of personal protective device against the falls shall be possible all along the jib.

5.4.4.5.2 Walkway

The width of the walkway shall comply with EN 13586:2004, Table 6 type 2.

When the size of the jib is sufficient to walk inside the jib (dimension between the walkway and the upper member equal or more than 1,8 m), toe boards shall be provided on each side of the walkway with a minimum height of 0,03 m. When the dimension between the walkway and the upper member is less than 1,8 m, toe board is provided only on one side (see Figure 1).

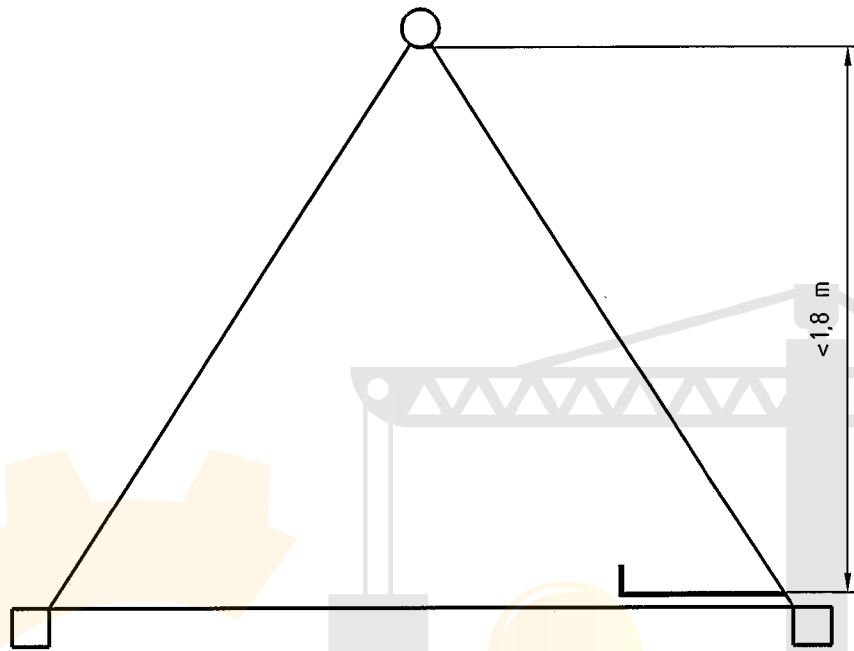

Figure 1

5.4.4.5.3 Position of the walkway, handrail and steel wire rope

Manufacturers shall take into consideration the dimension of the jib when determining the position of the walkway, hand rail and steel wire rope.

5.4.4.5.4 Basket

The minimum dimension of the length/width of the basket shall be $0,5 \times 0,35$ m.

Manufacturers shall take into consideration the weight and the number of persons when determining the basket.

The side protection shall comply with EN 13586:2004, Table 7, type 2, walkway.

Instructions and markings shall be provided for the use of the basket:

- how to reach the basket;
- admissible load and number of persons;
- warnings concerning residual risks e.g. shearing, entanglement.

5.4.5 Lighting

A fixed non-dazzling service lighting shall be provided and so arranged that the necessary illumination of the control is provided. The minimum illumination shall be 50 lux.

When the general area lighting does not permit sufficient illumination in a machinery cabinet, supplementary lighting shall be provided. For maintenance, the minimum illumination shall be 200 lux which may be obtained by additional movable lighting.

5.4.6 Outside indicators on the crane

5.4.6.1 When outside indicators on the crane are requested for anemometer and anti collision devices, see Annex C.

5.4.6.2 When cableless control is engaged, to fulfil requirements of EN 13557 (C.8) and of EN 12077-2 (5.5.1.2):

- it shall be indicated by an continuous green light located to be able to be seen by the persons next to the crane;
- a yellow light installed on the crane to be able to be seen by the driver shall give a warning of approach to the rated capacity at a value which gives the crane driver time to react to the warning and prevent the crane from being overloaded. This indicator is not necessary if this information is available on the remote control.

5.5 Noise reduction

5.5.1 Noise reduction at source at the design stage

Tower cranes shall be so designed and constructed that risks resulting from the emission of airborne noise are reduced to the lowest level taking account of technical progress and the availability of means of reducing noise, in particular, at source.

Recommended practice for the design of the low-noise machinery is given in EN ISO 11688-1.

NOTE EN ISO 11688-2 gives useful information on noise generation mechanism in machinery.

For tower cranes, the main source of noise is the lifting mechanism.

5.5.2 Information about the residual noise emitted

Information on the residual noise shall be given by the manufacturer of the tower crane, see also 7.2.5.

6 Verification of the safety requirements and/or protective measures

6.1 General

Only verifications of additional requirements of the Clause 5 are given in the Table 7, the others are already covered by the particular standard.

6.2 Method of verification

It is necessary to verify that the requirements of this European Standard have been incorporated in the design and manufacture of a tower crane. Either one or a combination of the following shall achieve this:

- a) measurement;
- b) calculation;
- c) visual examination;
- d) functional tests;

as described in Table 7 and Annex D, clause D.1.

To ensure fitness for purpose every single crane shall be checked individually in accordance with 6.3.

Table 7 — Methods to be used to verify conformity with the safety requirements and/or protective measures

Clause of this European Standard	Method of verification
5.2	Calculation, test and analysis
5.3.1	See Clause 6 of EN 13135-1:2003
5.3.2	See Clause 6 of EN 13135-2:2004
5.4.1	See Clause 6 of EN 13557:2003
5.4.1.3	Visual and design verification
5.4.1.4	Visual and design verification
5.4.1.5	Functional test
5.4.1.6	Geometrical verification
5.4.1.7	Geometrical verification
5.4.1.8	Measure and test
5.4.1.9	Functional test
5.4.2	See Clause 6 of EN 12077-2:1998
5.4.2.4	Functional test
5.4.2.5	Functional test
5.4.2.6	Functional test
5.4.2.7	Visual verification
5.4.2.8	Functional test
5.4.2.9	Functional test
5.4.3.1	Visual verification
5.4.3.2	Visual verification
5.4.4	See Clause 6 of EN 13586:2004
5.4.4.2	Geometrical verification
5.4.4.3	Visual and geometrical verification
5.4.4.4	Geometrical verification
5.4.4.5	Visual and geometrical verification
5.4.5	Visual verification
5.4.6	Functional and visual check
5.5	See 6.4 of this Standard

6.3 Fitness for purpose

To ensure fitness for purpose, each tower crane shall be checked according to D.2 and D.3.

As a general rule, this verification is done after the first erection and includes:

- visual inspection;

- functional checks;
- tests with load: static tests, dynamic tests.

Those verifications shall be done at the premises of the manufacturer or on site.

The test procedures and test conditions shall be taken from D.3.

Load tests shall be carried out with the crane configured as it is intended to be used without any modifications.

6.4 Noise measurement

6.4.1 Sound power level

The sound power level shall be measured according to Annex E.

NOTE Noise emission values obtained from measurements are the way to verify the result of the noise reduction measures taken at the design stage (see 5.5.1).

6.4.2 Emission sound pressure level at operator's station

The emission sound pressure level at operator's station shall be determined according to Annex E.

NOTE Noise emission values obtained from measurements or calculation are the way to verify the result of the noise reduction measures taken at the design stage (see 5.5.1).

7 Information for use

7.1 General

The information for use shall be in accordance with EN ISO 12100-2:2003, Clause 6.

7.2 Instructions handbook

7.2.1 General

An instruction handbook in accordance with EN 12644-1 shall be provided with each tower crane.

Clauses of EN 12644-1 shall be applied with the following modifications and additions, see Table 8.

Table 8 — Instruction handbook

EN 12644-1:2001	Scope	Modification	Subclause of this European Standard
5.1	General	completed by	7.2.2
5.2.1	Crane specification - General	completed by	7.2.3
5.2.3 i)	Erection and dismantling	completed by	7.2.4
5.2.3 l)	Technical data	completed by	7.2.5
5.3	Instruction for the users	completed by	7.2.6
5.5	Instruction for maintenance	completed by	7.2.7
5.6	Transportation	completed by	7.2.8

7.2.2 General

It is possible to include in the instruction handbook, the various documents which shall be provided with the crane (for example EC declaration of conformity, certificates).

NOTE The instruction handbook may be in separate parts; some of them can be delivered prior the crane itself to assist in prior planning.

7.2.3 Specifications - General

The instruction handbook of the crane may provide information on configurations and elements different from those corresponding to the first erection of the crane.

7.2.4 Erection and dismantling

The instructions for erection/dismantling shall contain a way to identify each element of the crane which are assembled/dissembled.

7.2.5 Information on noise emission

The instruction handbook shall contain information on the sound power level and the emission sound pressure level at the operator's position(s) as follows:

- A-weighted sound power level emitted by the machine (see E.2), where the A-weighted emission sound pressure level at the operator's position(s) exceeds 85 dB;

NOTE 1 Tower cranes being covered by directive 2000/14/EC, this value is the guaranteed value indicated on the marking of the machine and in the declaration of conformity.

NOTE 2 Guidance on the declaration of sound power level can be found in Position paper on guidelines for the application of the European Parliament and Council Directive 2000/14/EC on the approximation of the laws of the Member States relating to the noise emission in the environment by equipment for use outdoors.

- A-weighted emission sound pressure level at the operator's position(s) (in the cabin and/or when remote controls are provided, as conventionally determined at a distance of 10 m from the lifting mechanism, see E.3) where this exceeds 70 dB; where this level does not exceed 70 dB, this fact shall be indicated. The declaration of this value shall have the format of a single number declaration as defined in EN ISO 4871.
- Test code used, by reference to Annex E.

NOTE 3 EN ISO 4871 provides a method to determine noise emission values to be declared and to verify the declared values. The methodology is based on the use of the measured values and measurement uncertainties. The latter are the uncertainty associated to the measurement procedure (which is determined by the grade of accuracy of the measurement method used) and the production uncertainty (variation of noise emission from one machine to another of the same type made by the same manufacturer).

7.2.6 Instructions for the users

The conditions of use shall be indicated, in particular:

- information relating to the climatic conditions, in particular conditions of wind in service and out of service;
- instructions for handling the loads having a surface to the wind higher than that taken into account in calculations (in general $1 \text{ m}^2/\text{t}$);
- prohibition of the lifting of persons;

— data that has to be registered in a log book.

NOTE It is recommended to remind that the user is responsible for the application of the national regulation for use.

Instructions shall be given by the manufacturer to calibrate the indicators.

7.2.7 Instructions for maintenance

Instructions shall be given by the manufacturer concerning communication between the maintenance operator(s) and the crane driver which should be ensured, when movement is necessary with the guard removed during maintenance or adjustment and for specific operation (e.g. maintenance on the winch, change of rope, use of the basket on the jib).

NOTE Guidelines are given in FEM 1.007.

7.2.8 Transportation

It is not necessary to specify the means and the methods of fixing on the means of transport.

7.2.9 Installation of an anti-collision device or a working space limiter

For installation of any anti collision device or a working space limiter, the necessary information shall be given by the manufacturer of the crane in the instruction handbook.

7.3 Marking

7.3.1 Identification

Each tower crane shall bear, legibly and indelible, the following minimal information: (see example in Figure F.1)

- name and address of the manufacturer or his authorised representative;
- mandatory marks (for EU/EES countries: CE marking and guaranteed sound power level as requested by directive 2000/14/EC);
- designation of series or type;
- the serial number;
- year of manufacturing.

NOTE 1 Other marking may be necessary for specific equipment (e.g. transport equipment).

NOTE 2 CE marking covers all the components that could be delivered by the manufacturer as described in the instruction handbook or documentation of a crane.

Nevertheless, some components may be CE marked due to other directives (e.g. LVD, EMC, ...) than the machinery directive.

7.3.2 Warnings and instructions

The following warnings and instructions shall be provided by the manufacturer by means of plates or signs:

- Rated capacity (diagram or table) at each control station (cabin or control station on the crane); for remote (cable or radio) control, the information shall be:

- on the remote control, or
- on a separate plate attached to the remote control, or
- on plate (s) visible from the ground (e.g. on the jib);
- no unauthorised ascent (access point of the crane); see example in Figure F.2;
- prohibition to remain within the working radius of the slewing platform (access point of the crane) where applicable; see example in Figure F.3;
- free jib slewing, see example in Figure F.5;
- read the instruction handbook, see example in Figure F.4.

Warning and instruction plates shall be provided in the language of the country where the crane is used.

Warning and information signs shall be in accordance with ISO 3864 and ISO 13200.

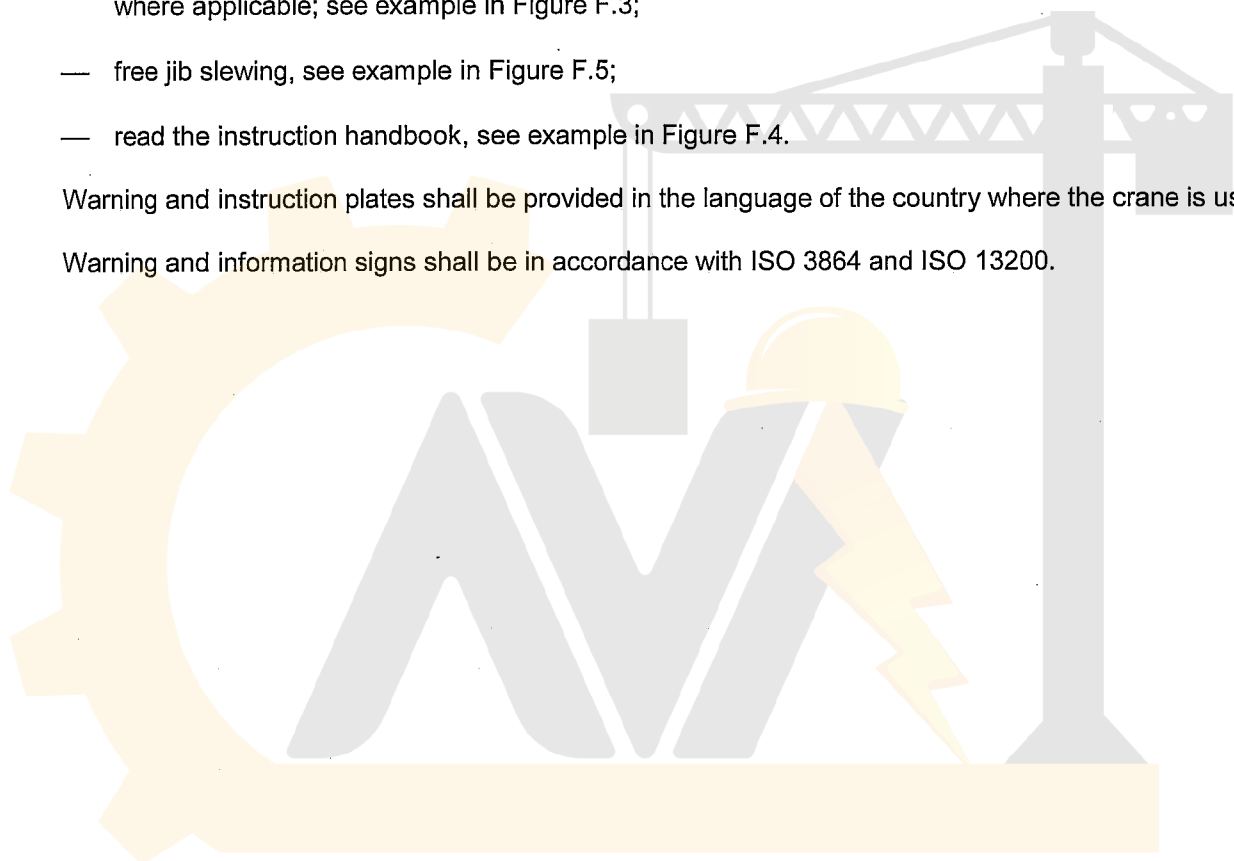

آریا ایمن آوات

Annex A (normative)

Stability requirements

A.1 General

This Annex A specifies the conditions to be met in addition to 9.15 of booklet 9 of FEM 1.001:1998 when verifying, by calculation, the stability of tower cranes that are subject to tipping and drifting.

A.2 Calculations

In addition to the load cases I to IV of Table T.9.15.2 of FEM of 1.001:1998 condition V in accordance with Table A.1 shall be met.

Table A.1

Condition	Loading	Load factor to be considered
V. Stability during erection or dismantling see Figure 1	Loads induced by the dead weight	1,0
	Horizontal applied load	0,1 P2
	Vertical applied load	1,16 P2
	Wind load	1,0 W3
	Inertia forces	1,0 D

where

D are the inertia forces from drives in accordance with FEM 1.001:1998, 2.2.3;

P2 is the weight of the part being installed/removed during erection or dismantling;

W3 is the in-service wind effect W1 or the effect of the wind limit for erection work in accordance with the instruction handbook of the manufacturer.

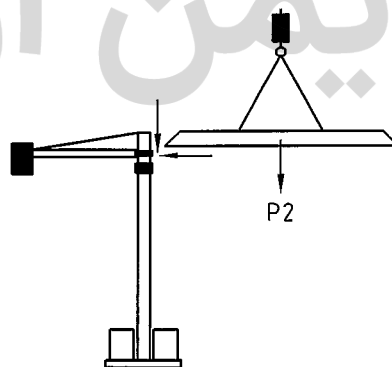

Figure A.1 — Example - Application of a load P2 for fitting a jib

Annex B (informative)

Requirements for the provision of anti-collision on tower crane

B.1 Introduction

This annex specifies the requirements for the installation of anti-collision devices on tower crane.

The purpose of the anti collision devices are to avoid the following risks:

- risks of collision between the moving crane and fixed obstacles;
- risks of over flying forbidden or critical areas;
- risks of collision between several cranes in motion.

NOTE The decision to install such a device on a crane is under the responsibility of the user depending of the risk analysis when the cranes are erected on the job site.

B.2 Power supply

The anti collision devices installed on various cranes shall operate on each crane as long as at least one crane is in service.

The power supply for the anti collision device may be taken on the crane.

B.3 Requirements

The device shall be at least a category 2 device as in 6.2.3 of EN 954-1:1996.

NOTE Periodic control required by category 2 may be automatic without crane driver's intervention or by manual start of the verification in a predetermined position following a given periodicity.

B.4 Information to be provided

B.4.1 For the driver

When there is a cabin, indications shall be provided to crane driver to allow him to keep control on the driving and to avoid dangerous areas.

Furthermore stopping of the system function due to:

- a fault, or
- a voluntary action

shall be indicated.

NOTE This information in the field of vision of the crane driver may be given by sound or visual means.

B.4.2 For the surrounding people

Stopping of the system function due to:

- a fault, or
- a voluntary action

shall be indicated to surrounding people by a white flashing light visible from the worksite (see 5.4.6.1).

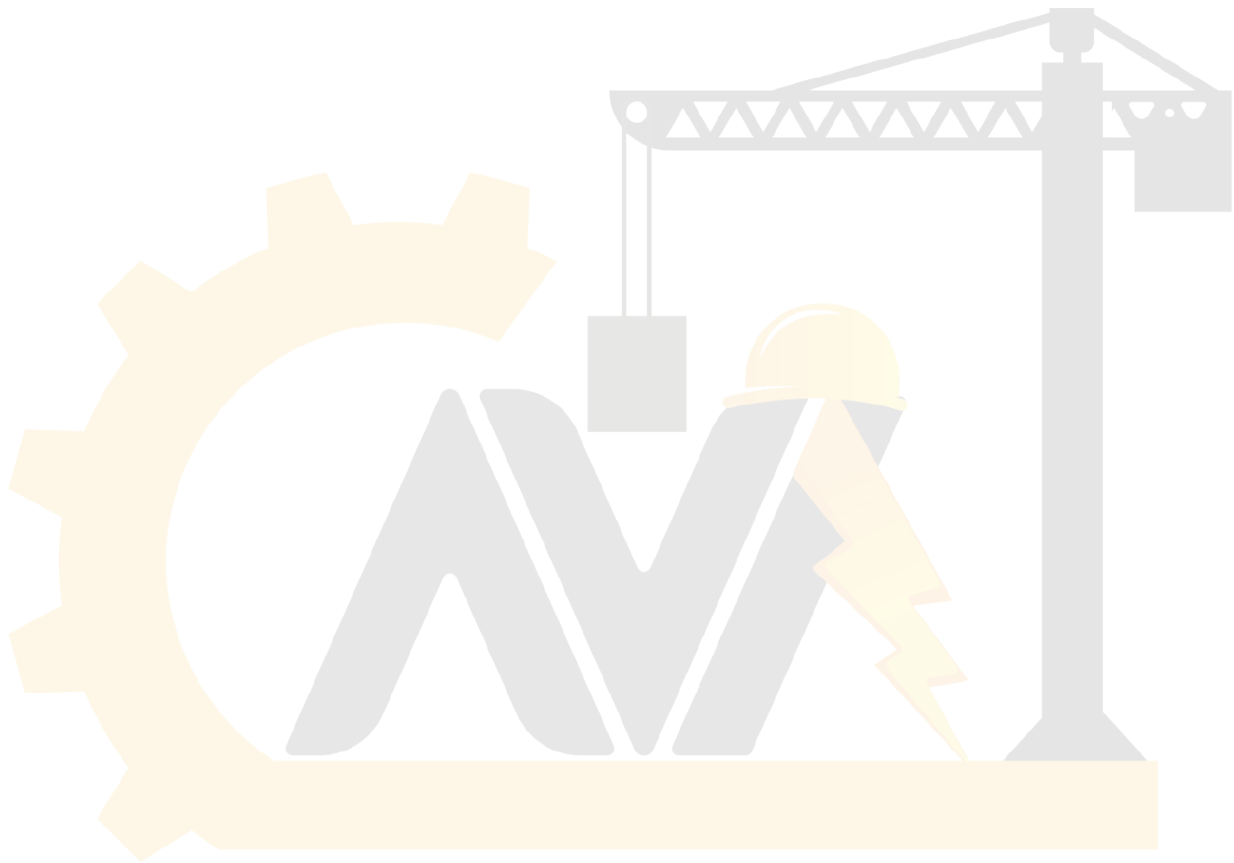

آریا ایمن آوات

Annex C (normative)

Outside indicators on the crane

C.1 When outside indicators in order to inform the persons working on the site about the crane condition are used, the type of the light signals shall be as given in C.2 and C.3. The light signals shall be visible by all the persons concerned.

C.2 When an anemometer is installed and when outside indicators are requested by local authorities. The light used shall be:

- a yellow flashing light for the warning level;
- a red flashing light for the alarm level.

C.3 When an anti-collision device is installed and when outside indicators are requested by local authorities, the light indicating that the device is out of order or in fault, shall be a white flashing light.

NOTE In some cases when local authorities request to have a warning indicating that the crane is in free slewing mode, a flashing green light should be used.



آريا ايمن آوات

Annex D (normative)

Verification of the safety requirements and/or protective measures

D.1 Design check

The design check is the verification of the calculations for the crane.

All calculations are required to be in accordance with accepted standards and rules.

When measuring load effects, the measured values shall be documented.

The conformity of the design drawings with the calculations and other relevant standards specified shall be checked.

All electric, hydraulic and pneumatic circuit diagrams shall be checked.

Field verification of individual components is acceptable in lieu of formal calculations when formally recorded.

When components, which have already been checked, are used on another model crane, they do not require to be checked again, if the applied loading is equal or less than the original loading.

D.2 Structural inspection

The as-built crane shall be compared to the documentation as noted in D.1.

All necessary certificates, the instruction handbook, rated capacity charts for the configuration in use, as well as all electric, hydraulic and pneumatic diagrams shall be available.

The erection and dismantling instructions shall be available on cranes, which are intended to be moved to other work sites.

A check shall be made to confirm that the manufacturing of the crane has been generally in accordance with accepted engineering principles and practice.

Checked crane components do not need to be verified again.

D.3 Acceptance test

D.3.1 General

To confirm the tower crane's fitness for purpose, an acceptance test shall be performed. The test shall include at least the following items:

- a) identification of the crane including marking and classification;
- b) function tests of the drives as well as of the limiting and indicating devices (in accordance with D.3.2);

- c) safety devices;
- d) load test in accordance with D 3.2 and D 3.3.

D.3.2 Function test without load

All functions shall be performed throughout the whole range of admissible movements up to the maximum operating speeds.

NOTE This test serves the purpose of ascertaining the effectiveness of all indicating and limiting devices as well as the brakes.

D.3.3 Load tests

D.3.3.1 General

Load tests shall be performed taking into account the positions and configurations causing the maximum loads or the maximum tensions in the most important crane components. The manufacturer shall specify the positions of the loads. The special load curves mentioned in the table are load curves calculated with reduced acceleration and speeds and/or permissible wind speeds which are specified by the manufacturer.

The procedure to test tower crane with a rated capacity above 100 t shall be determined by the manufacturer.

NOTE The declaration of conformity of the tower crane confirms that fitness for purpose has been achieved, there is no need to produce a further test report or test certificate giving the result of the fitness for purpose.

D.3.3.2 Static test

Table D.1

Column 1	2	3
Test load	125 % (in % of the load curve)	125 % (in % of the special load curve)
admissible movement	successive	not prescribed, static test in accordance with column 2 is sufficient
admissible speed	reduced speed in accordance with manufacturer's specifications	
admissible wind speed	calm or in accordance with manufacturer's specifications, respectively	

The test load shall have a distance of 100 mm to 200 mm from the floor for a period of time of at least 10 min.

The static test shall be considered successful if no ruptures, permanent deformations or damages affecting the function or safety of the crane are visible and if no connections have loosened or become damaged.

D.3.3.3 Dynamic test**Table D.2**

Test load	110 % (in % of the load curve)	110 % (in % of the special load curve)
admissible movements	combined	
admissible speed	maximum speed which is admissible for the suspended load	
admissible wind speed	maximum operating wind speed as specified by the manufacturer	

The tests shall include the repeated starting and stopping of each movement throughout the whole sequence of the movement.

The dynamic test shall be considered successful if the corresponding components have performed their functions and if the subsequent examination has not revealed any damage on the components of drive or supporting structure and if no connection has loosened or sustained damage.

D.3.4 Verification of the stability

For tower cranes, the stability test is carried out by calculations and static test.

آریا ایمن آوات

Annex E (normative)

Noise test code

E.1 General

E.1.1 This noise test code specifies all the information necessary to carry out efficiently and under standardised conditions the determination and declaration of the noise emission characteristics of tower cranes.

Noise emission characteristics include the emission sound pressure level at the operator's position and the sound power level. The determination of these quantities is necessary for:

- manufacturers to declare the noise emitted;
- comparing the noise emitted by machines in the family concerned;
- purposes of noise control at the source at the design stage.

The use of this noise test code ensures reproducibility of the determination of the noise emission characteristics within specified limits determined by the grade of accuracy of the basic noise measurement method used. Noise measurement methods allowed by this European Standard are engineering methods (grade 2).

E.1.2 As a general rule, the energy source powering the tower crane is independent from the crane, so, only the noise emission of the lifting mechanism shall be determined.

Where, exceptionally, an energy generator is an integral part of the crane, the measurement shall refer to the whole assembly.

E.2 A-weighted sound power level

E.2.1 Mounting of the equipment

The lifting mechanism during the test shall be mounted in one of the following ways.

The position of the lifting mechanism shall be described in the test report.

(a) Lifting mechanism at ground level

The crane shall be mounted on a flat reflecting surface of concrete or non-porous asphalt.

(b) Lifting mechanism on the jib stay

The lifting mechanism shall be at least 12 m above the ground on a flat reflecting surface of concrete or non-porous asphalt.

(c) Lifting mechanism fixed to the ground

The lifting mechanism shall be fixed to a flat reflecting surface of concrete or non-porous asphalt.

During the test, the lifting mechanism, and the energy generator when it is an integral part of the crane, shall be installed and used in accordance with the manufacturer's instructions.

E.2.2 Test method

E.2.2.1 General

For tower cranes, the A-weighted sound power level shall be measured in accordance with EN ISO 3744 with the following modifications and additions.

NOTE 1 This document is under revision and will include an annex about the determination of A-weighted sound power level of noise sources normally used outdoors with provisions that are similar to the following modifications and additions.

NOTE 2 The following test method is in line with that specified in 2000/14/EC.

E.2.2.2 Measurement at ground level

Instead of the microphone positions specified in 7.2.1 and 7.2.2 of EN ISO 3744:1995, a set of 6 microphones on a hemispherical measurement surface of radius r shall be used. The locations of the 6 microphone positions are listed in the form of Cartesian coordinates in Table E.1. The radius r of the hemisphere shall be equal to or greater than twice the largest dimension of the reference parallelepiped. The reference parallelepiped is defined as the smallest possible rectangular parallelepiped just enclosing the equipment (without attachments) and terminating on the reflecting plane. The radius of the hemisphere shall be rounded to the nearest higher of the following values: 4 m, 10 m, 16 m.

The microphones shall be positioned at locations 2, 4, 6, 8, 10 and 12 as allowed according to 7.4.2 of EN ISO 3744:1995. The condition for reducing the number of microphone positions specified in 7.4.2 of EN ISO 3744:1995 is fulfilled for tower cranes.

Table E.1 — Coordinates of the 6 microphone positions

Number of microphone	x/r	y/r	z
2	0,7	0,7	1,5 m
4	-0,7	0,7	1,5 m
6	-0,7	-0,7	1,5 m
8	0,7	-0,7	1,5 m
10	-0,27	0,65	0,71 r
12	0,27	-0,65	0,71 r

E.2.2.3 Measurements carried out at jib-height

Where the lifting mechanism is located at the jib-height, the measurement surface shall be a sphere of 4 m radius, the centre of which shall coincide with the geometrical centre of the winch.

Its area shall be taken equal to 200 m².

Four microphone positions on a horizontal plane passing through the geometric centre of the mechanism shall be used (see Figure E.1).

with $L = 2,80$ m;

and $d = 2,80 - l/2$;

where

L is the half-distance between two consecutive microphone positions;

- l is the length of mechanism (along axis of jib);
- b is the width of mechanism;
- h is the height of mechanism;
- d is the distance between microphone support and mechanism in direction of jib.

The other two microphone positions shall be located at the points of intersection of the sphere and the vertical line passing through the geometric centre of the mechanism.

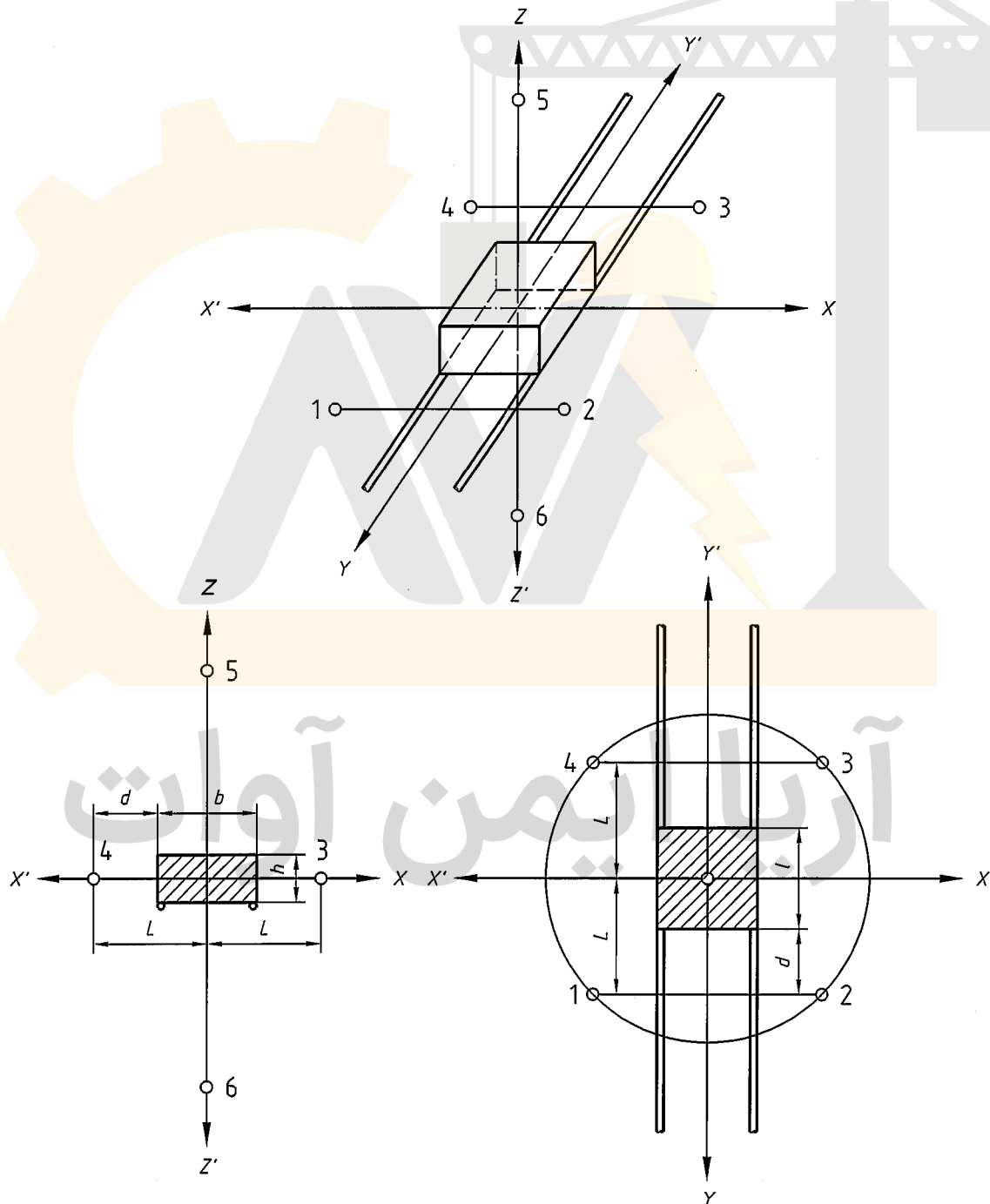

Figure E.1 — Arrangement of microphones where the lifting mechanism is located on the jib stay

E.2.2.4 Environmental correction K_{2A}

Equipment shall be measured on a reflecting surface of concrete or non-porous asphalt, without any large obstacles in the vicinity of the crane, then the environmental correction K_{2A} is set to $K_{2A} = 0$.

E.2.2.5 Operating conditions

The two following tests shall be carried out one after the other.

— Test free of load

The lifting mechanism shall operate free of load, with its drum turning at the rotation speed corresponding to the maximum hook-displacement speed, in the raising and lowering modes. This speed shall be specified by the manufacturer. The greater of the two sound power levels (raising or lowering) shall be used as the result of the test.

— Test under load

The lifting mechanism shall operate with a cable tension at the drum corresponding to the maximum load (for the minimum radius) with the hook moving at the maximum speed. The load and speed figures shall be specified by the manufacturer. The speed shall be checked during the test.

E.2.2.6 Period(s) of observation/determination of resulting sound power level

For the measurement of the sound pressure level of the lifting mechanism, the measuring period shall be $(t_r + t_f)$ seconds:

- t_r being the period in seconds prior to activation of the brake, with the lifting mechanism operating in the manner specified above. For the purpose of the test, $t_r = 3$ s;
- t_f being the period in seconds between the moment when the brake is activated and that when the hook comes to a complete standstill.

If an integrator is used, the integration period shall be equal to $(t_r + t_f)$ seconds.

The root mean square value (energy average) at a microphone position i shall be given by:

$$L_{pi} = 10 \lg [(t_r 10^{0,1L_{ri}} + t_f 10^{0,1L_{fi}}) / (t_r + t_f)]$$

L_{ri} being the sound pressure level at microphone position i during period t_r .

L_{fi} being the sound pressure level at microphone position i during breaking period t_f .

E.2.2.7 Calculation of surface sound pressure level

The surface sound pressure level shall be determined at least three times for each operation condition, under load and free of load, as defined in E.2.2.5. If at least two of the determined values do not differ by more than 1 dB, further measurements will not be necessary; otherwise the measurements shall be continued until two values differing by no more than 1 dB are obtained. The A-weighted surface sound pressure level to be used for calculating the sound power level is the arithmetic mean of the two highest values that do not differ by more than 1 dB.

E.3 A-weighted emission sound pressure level at the operator's position

E.3.1 General

The A-weighted emission sound pressure level at the operator's position shall be determined:

- either from measurements in the cabin as specified in E.3.2;
- or, where remote controls are provided, calculated according to EN ISO 11203 from the value of the A-weighted sound power level; the sound pressure level at the operator's position shall be indicated at a distance of 10 m from the lifting mechanism.

The determination is conducted on a single crane per model, with the noisiest lifting mechanism. It is not required to determine and declare the sound pressure level for each lifting mechanism than can be mounted on the tower crane.

E.3.2 Test method, mounting and operating conditions during test

The measurement of the A-weighted emission sound pressure level at the operator's position shall be carried out in accordance with EN ISO 11201:1995.

The lifting mechanism and the cabin shall be in a working position:

- identified by the manufacturer and
- indicated in the test report.

The A-weighted **emission** sound pressure level shall be measured with air conditioning at the maximum speed and windows closed in the operating conditions specified in E.2.2.5 and for the period(s) of observation specified in E.2.2.6.

E.3.3 Calculation of emission sound pressure level

The emission sound pressure level shall be determined at least three times. If at least two of the determined values do not differ by more than 1 dB, further measurements will not be necessary; otherwise the measurements shall be continued until two values differing by no more than 1 dB are obtained.

The value of the A-weighted emission sound pressure level to be retained is the arithmetic mean of the two highest values that do not differ by more than 1 dB.

E.4 Noise declaration

The A-weighted sound power level and the A-weighted emission sound pressure level used in the noise declaration shall be the highest level of those calculated by the formula specified in E.2.2.6.

The noise declaration shall be made as specified in 7.2.5 of this European Standard.

Annex F (informative)

Marking - Example of layout

Typen Schild	110 x 210 mm
Typ plate	110 x 210 mm
Plaque du type	110 x 210 mm

Typen:
Typ:
Type:

Werk-Nr:
Serial-No.:
N° de série:

Baujahr:
Year of construction:
Année de construction:

CE

Name und Adresse von dem Hersteller
Name and adress of the manufacturer
Nom et adresse du fabricant

Figure F.1 — Example of identification

آریا ایمن آوات

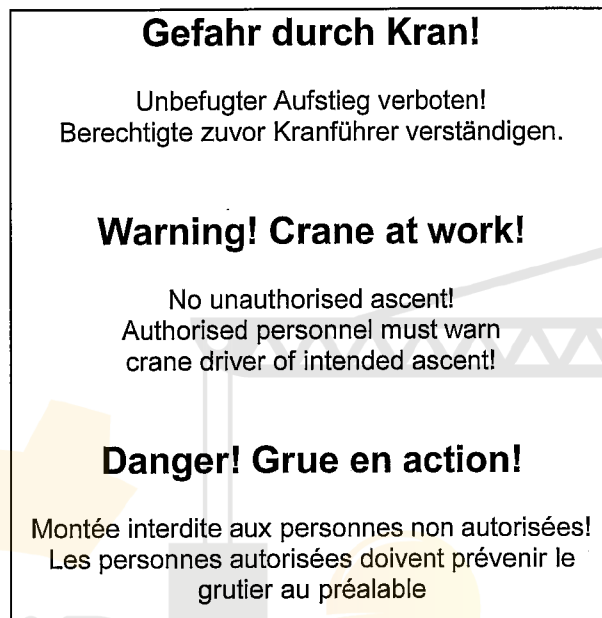

Figure F.2 — Examples of no unauthorised ascent

Lebensgefahr!

Der Aufenthalt
unter der angehobenen Last
und im Schwenkbereich
der Drehbühne ist verboten.

Warning!

It is prohibited to remain
under the suspended load
or within the working radius
of the slewing platform.

Danger!

il est interdit de stationner
sous la flèche en charge et
dans le rayon d'action
de la plate-forme.

Figure F.3

آریا ایمن آوات

D	Vor der Montage und Inbetriebnahme sowie für die Bedienung und Wartung unbedingt die Betriebsanleitung beachten!	Before erection and starting of the plant as well as for the operation and maintenance please strictly follow the instruction handbook!	GB
F	Avant montage et mise en marche ainsi que pour la commande et le service il est absolument nécessaire de respecter strictement les notices d'instructions!	Antes del montaje y puesta en marcha y para el manejo y manutención es imprescindible leer el manual de instrucciones	E
I	Prima del montaggio e della messa in funzione cos' come prima di ogni operazione di manutenzione prestare scrupolosamente attenzione alle norme e istruzioni date!	Instruções de serviço: Estas devem ser observadas antes de serem realizadas a montagem e a colocação assim como qualquer operação e manutenção dos equipamentos!	P
NL	Zowel voor de Montage en het in Bedrijf stellen als voor de Bedienung en het Onderhoud de Handleiding goed bestuderen!	Til montage og idrifttagning samt til betjening og vedligeholdelse er det ubetinget nødvendigt at overholde driftsvejledningen!	DK
CZ	Před montáží a před uvedením do provozu, jakož i při obsluze a údržbě, je nutné dbát návodu k obsluze!	Przed montażem, uruchomieniem lub naprawą instrukcje obsługi koniecznie przestrzegać!	PL
KR	Prije montaze i stavljanja u pogon, kod posluživanja kao i kod održavanja, pridržavati se bezuvjetno pogonske upute!	Szerelés és üzembhelyezés előtt valamint kezeléshez és karbantartáshoz a kezelési utasítást feltétlenül vegyük figyelembe!	H
GR	Εφαρμόζετε οποσδήποτε τις οδηγίες χρήσεως πριν το μοντάρισμα, την λειτουργία αλλά και για τον χειρισμό και την συντήρησή!	Ved montasje og idriftsettelse samt for betjening og vedlikehold er det absolut nødvendig å følge bruksanvisningen.	N
S	Läs igenom instruktionsboken före monteringen och driftstart samt för betjäning och underhåll.	Ennen nosturin pystytystä ja käyttöönottoa sekä käyttää ja kunnossapitoa perehdy huolellisesti käyttöohjeisiin.	FI
TR	Montaj ve vinçin çalıştırılmasından önce vinçin kullanılması ve bakımı için mutlaka vinç kullanma Nizamnamesine dikkat edilmesi gerekir.	Перед монтажом и вводом в эксплуатацию а так же для управления и технического обслуживания необходимо внимательно ознакомиться с инструкцией по эксплуатации и следовать её рекомендациям!	SU
B	Vorafgaandaan montage en inbedrijfstelling alsmede voor bediening en onderhoud zeer beslist de bedieningshandleiding lezen!		

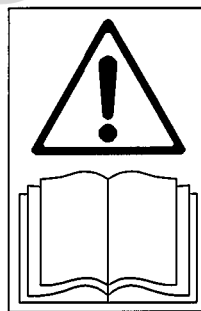
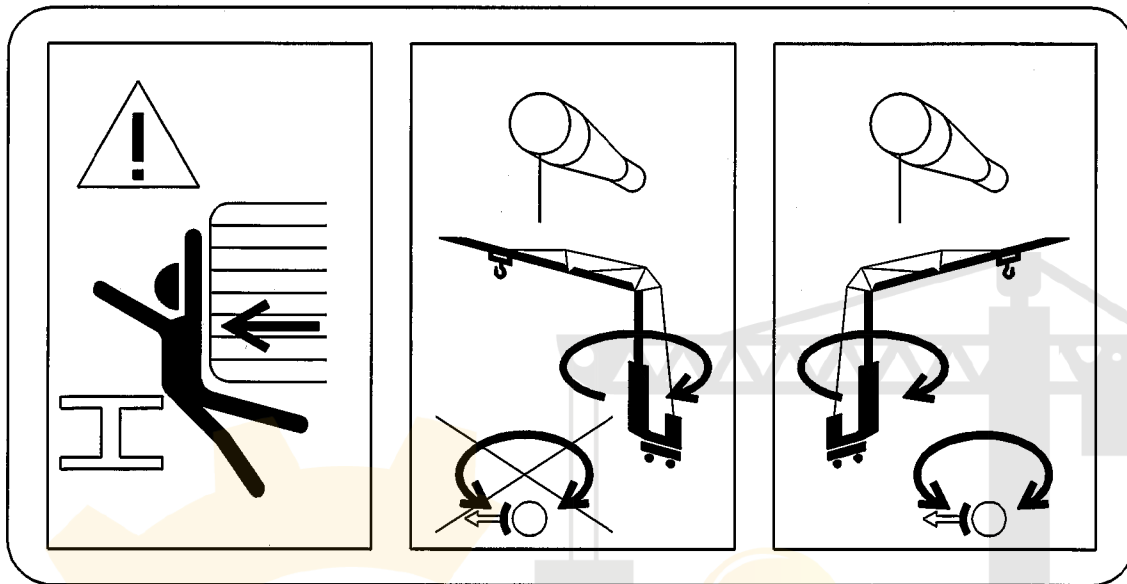

Figure F.4



Quetschgefahr!
 Risque d'écrasement!
 Crushing hazard!

Ausleger in den Wind drehen
 Tourner la flèche dans la direction du vent
 Turn the jib in the wind direction

Ausleger windfrei stellen
 Mettez la flèche en girouette
 Put the crane to free jib slewing

<p>Crushing hazard</p>	<p>Hazard due to the free slewing of the jib</p>	<p>Crushing hazard during the free jib slewing</p>

Figure F.5 — Examples of free jib slewing

Annex G (informative)

Selection of a suitable set of crane standards for a given application

Is there a product standard in the following list that suits the application?	
EN 13000:2004	Cranes — Mobile cranes
prEN 14439:2004	Cranes — Safety — Tower cranes
prEN 14985	Cranes — Slewing jib cranes
prEN 15011	Cranes — Bridge and gantry cranes
EN 13852-1:2004	Cranes — Offshore cranes — Part 1: General purpose offshore cranes
EN 13852-2:2004	Cranes — Offshore cranes — Part 2: Floating cranes
EN 14492-1:2006	Cranes — Power driven winches and hoists — Part 1: Power driven winches
EN 14492-2:2006	Cranes — Power driven winches and hoists — Part 2: Power driven hoists
EN 12999:2002	Cranes — Loader cranes
EN 13157:2004	Cranes — Safety — Hand powered lifting equipment
EN 13155:2003	Cranes — Non-fixed load lifting attachments
EN 14238:2004	Cranes — Manually controlled load manipulating devices
EN 15056:2006	Cranes — Requirements for container handling spreaders

YES

NO

Use it directly, plus the standards that are referred to

Use the following:	
EN 13001-1:2004	Cranes — Safety — General design — Part 1: General principles and requirements
EN 13001-2:2004	Cranes — Safety — General design — Part 2: Load actions
CEN/TS 13001-3-1:2004	Cranes — General design — Part 3-1: Limit states and proof of competence of steel structures
CEN/TS 13001-3-2:2004	Cranes — General design — Part 3-2: Limit states and proof of competence of wire ropes in reeving systems
prCEN/TS 13001-3-3	Cranes — General design — Part 3-3: Limit states and proof of competence of wheel / rail contacts
EN 13135-1:2003	Cranes — Safety – Design – Requirements for equipment — Part 1: Electrotechnical equipment
EN 13135-2:2004	Cranes — Equipment — Part 2: Non-electrotechnical equipment
EN 13557:2003	Cranes — Controls and control stations
EN 12077-2:1998	Cranes safety — Requirements for health and safety — Part 2: Limiting and indicating devices
EN 13586:2004	Cranes — Access
EN 14502-1:2005	Cranes — Equipment for the lifting of persons — Part 1: Suspended baskets
EN 14502-2:2005	Cranes — Equipment for the lifting of persons — Part 2: Elevating control stations
EN 12644-1:2001	Cranes — Information for use and testing — Part 1: Instructions
EN 12644-2:2000	Cranes — Information for use and testing — Part 2: Marking

Annex ZA
(informative)

**Relationship between this European Standard and the Essential Requirements of
EU Directive 98/37/EC**

This European Standard has been prepared under a mandate given to CEN by the European Commission and the European Free Trade Association to provide a means of conforming to Essential Requirements of the New Approach Directive: Directive Machinery 98/37/EC amended by 98/79/CE.

Once this standard is cited in the Official Journal of the European Communities under that Directive and has been implemented as a national standard in at least one Member State, compliance with the normative clauses of this standard confers, within the limits of the scope of this standard, a presumption of conformity with the relevant Essential Requirements of that Directive and associated EFTA regulations.

WARNING — Other requirements and other EU Directives may be applicable to the product(s) falling within the scope of this standard.



آریا ایمن آوات

Bibliography

- [1] Directive 2000/14/EC, *Noise directive*
- [2] Directive 89/336/EEC, *Electromagnetic compatibility (EMC) directive*
- [3] Directive 73/23/EC, *Electrical Equipment directive*
- [4] EN ISO 11688-2, *Acoustics — Recommended practice for the design of low-noise machinery and equipment — Part 2: Introduction to the physics of low-noise design (ISO/TR 11688-2:1998)*
- [5] prEN ISO 13849-1:2002, *Safety of machinery — Safety-related parts of control systems — Part 1: General principles for design (ISO/DIS 13849-1:2004)*
- [6] FEM 1.007, *Recommendation to maintain tower cranes in safe condition*
- [7] EN ISO 11688-1:1998, *Acoustics — Recommended practice for the design of low-noise machinery and equipment — Part 1: Planning (ISO/TR 11688-1:1995)*
- [8] ISO 4310, *Cranes — Test code and procedures*
- [9] EN 294, *Safety of machinery — Safety distance to prevent danger zones being reached by the upper limbs*
- [10] EN 13001, *Cranes — Safety — General design*

آریا ایمن آوات

BSI — British Standards Institution

BSI is the independent national body responsible for preparing British Standards. It presents the UK view on standards in Europe and at the international level. It is incorporated by Royal Charter.

Revisions

British Standards are updated by amendment or revision. Users of British Standards should make sure that they possess the latest amendments or editions.

It is the constant aim of BSI to improve the quality of our products and services. We would be grateful if anyone finding an inaccuracy or ambiguity while using this British Standard would inform the Secretary of the technical committee responsible, the identity of which can be found on the inside front cover.
Tel: +44 (0)20 8996 9000. Fax: +44 (0)20 8996 7400.

BSI offers members an individual updating service called PLUS which ensures that subscribers automatically receive the latest editions of standards.

Buying standards

Orders for all BSI, international and foreign standards publications should be addressed to Customer Services. Tel: +44 (0)20 8996 9001.
Fax: +44 (0)20 8996 7001. Email: orders@bsi-global.com. Standards are also available from the BSI website at <http://www.bsi-global.com>.

In response to orders for international standards, it is BSI policy to supply the BSI implementation of those that have been published as British Standards, unless otherwise requested.

Information on standards

BSI provides a wide range of information on national, European and international standards through its Library and its Technical Help to Exporters Service. Various BSI electronic information services are also available which give details on all its products and services. Contact the Information Centre.
Tel: +44 (0)20 8996 7111. Fax: +44 (0)20 8996 7048. Email: info@bsi-global.com.

Subscribing members of BSI are kept up to date with standards developments and receive substantial discounts on the purchase price of standards. For details of these and other benefits contact Membership Administration.
Tel: +44 (0)20 8996 7002. Fax: +44 (0)20 8996 7001.
Email: membership@bsi-global.com.

Information regarding online access to British Standards via British Standards Online can be found at <http://www.bsi-global.com/bsonline>.

Further information about BSI is available on the BSI website at <http://www.bsi-global.com>.

Copyright

Copyright subsists in all BSI publications. BSI also holds the copyright, in the UK, of the publications of the international standardization bodies. Except as permitted under the Copyright, Designs and Patents Act 1988 no extract may be reproduced, stored in a retrieval system or transmitted in any form or by any means – electronic, photocopying, recording or otherwise – without prior written permission from BSI.

This does not preclude the free use, in the course of implementing the standard, of necessary details such as symbols, and size, type or grade designations. If these details are to be used for any other purpose than implementation then the prior written permission of BSI must be obtained.

Details and advice can be obtained from the Copyright & Licensing Manager.
Tel: +44 (0)20 8996 7070. Fax: +44 (0)20 8996 7553.
Email: copyright@bsi-global.com.