

BS EN 1808:2015



BSI Standards Publication

**Safety requirements for
suspended access equipment
— Design calculations, stability
criteria, construction —
Examinations and tests**

آریا ایمن آوات

bsi.

...making excellence a habit.™

National foreword

This British Standard is the UK implementation of EN 1808:2015. It supersedes BS EN 1808:1999+A1:2010 which is withdrawn.

The UK participation in its preparation was entrusted to Technical Committee B/514/39, Suspended access equipment.

A list of organizations represented on this committee can be obtained on request to its secretary.

This publication does not purport to include all the necessary provisions of a contract. Users are responsible for its correct application.

© The British Standards Institution 2015. Published by BSI Standards Limited 2015

ISBN 978 0 580 72823 5

ICS 53.020.99

Compliance with a British Standard cannot confer immunity from legal obligations.

This British Standard was published under the authority of the Standards Policy and Strategy Committee on 30 April 2015.

Amendments issued since publication

Date	Text affected
------	---------------

آریا ایمن آوات

EUROPEAN STANDARD

EN 1808

NORME EUROPÉENNE

EUROPÄISCHE NORM

April 2015

ICS 53.020.99

Supersedes EN 1808:1999+A1:2010

English Version

Safety requirements for suspended access equipment - Design calculations, stability criteria, construction - Examinations and tests

Exigences de sécurité des plates-formes suspendues à niveau variable - Calculs, stabilité, construction - Examen et essais

Sicherheitsanforderungen an hängende Personenaufnahmemittel - Berechnung, Standsicherheit, Bau - Prüfungen

This European Standard was approved by CEN on 10 February 2015.

CEN members are bound to comply with the CEN/CENELEC Internal Regulations which stipulate the conditions for giving this European Standard the status of a national standard without any alteration. Up-to-date lists and bibliographical references concerning such national standards may be obtained on application to the CEN-CENELEC Management Centre or to any CEN member.

This European Standard exists in three official versions (English, French, German). A version in any other language made by translation under the responsibility of a CEN member into its own language and notified to the CEN-CENELEC Management Centre has the same status as the official versions.

CEN members are the national standards bodies of Austria, Belgium, Bulgaria, Croatia, Cyprus, Czech Republic, Denmark, Estonia, Finland, Former Yugoslav Republic of Macedonia, France, Germany, Greece, Hungary, Iceland, Ireland, Italy, Latvia, Lithuania, Luxembourg, Malta, Netherlands, Norway, Poland, Portugal, Romania, Slovakia, Slovenia, Spain, Sweden, Switzerland, Turkey and United Kingdom.

آریا ایمن آوات



EUROPEAN COMMITTEE FOR STANDARDIZATION
COMITÉ EUROPÉEN DE NORMALISATION
EUROPÄISCHES KOMITEE FÜR NORMUNG

CEN-CENELEC Management Centre: Avenue Marnix 17, B-1000 Brussels

Contents

Page

Foreword.....	3
Introduction	4
1 Scope	5
2 Normative references	6
3 Terms and definitions, symbols and abbreviations.....	6
4 Hazards and preventative actions.....	23
5 Safety requirements and/or measures	27
6 Structural, stability and mechanical calculations for SAE	27
7 Suspended platforms	47
8 Hoisting systems	57
9 Suspension rigs	66
10 Electrical, hydraulic and pneumatic systems.....	72
11 Control systems.....	73
12 Verification and certification	77
13 Marking of SAE	79
14 Accompanying documents.....	81
Annex A (normative) Platform type-tests	85
Annex B (normative) Hoist and secondary device type-tests	90
Annex C (normative) Suspension rig type-tests.....	96
Annex D (informative) Guidance on the presentation and interpretation of loads imposed by SAE structures	98
Annex E (informative) Maximum permitted horizontal displacement of platform.....	101
Annex F (normative) Guidance on the requirements for wireless control systems	105
Annex G (normative) Design requirements for rail tracks, monorail tracks and support systems	107
Annex ZA (informative) Relationship between this European Standard and the Essential Requirements of EU Directive 2006/42/EC	130
Bibliography	131

Foreword

This document (EN 1808:2015) has been prepared by Technical Committee CEN/TC 98 "Lifting platforms", the secretariat of which is held by DIN.

This European Standard shall be given the status of a national standard, either by publication of an identical text or by endorsement, at the latest by October 2015 and conflicting national standards shall be withdrawn at the latest by October 2015.

Attention is drawn to the possibility that some of the elements of this document may be the subject of patent rights. CEN [and/or CENELEC] shall not be held responsible for identifying any or all such patent rights.

This document supersedes EN 1808:1999+A1:2010.

This document has been prepared under a mandate given to CEN by the European Commission and the European Free Trade Association, and supports essential requirements of EU Directive(s).

For relationship with EU Directive(s), see informative Annex ZA, which is an integral part of this document.

This document also includes information that building designers, structural engineers and contractors need to consider before specific suspended access equipment (SAE) manufacturers/suppliers are appointed.

According to the CEN-CENELEC Internal Regulations, the national standards organizations of the following countries are bound to implement this European Standard: Austria, Belgium, Bulgaria, Croatia, Cyprus, Czech Republic, Denmark, Estonia, Finland, Former Yugoslav Republic of Macedonia, France, Germany, Greece, Hungary, Iceland, Ireland, Italy, Latvia, Lithuania, Luxembourg, Malta, Netherlands, Norway, Poland, Portugal, Romania, Slovakia, Slovenia, Spain, Sweden, Switzerland, Turkey and the United Kingdom.

آریا ایمن آوات

Introduction

This European Standard is a type C standard as stated in EN ISO 12100.

The machinery concerned and the extent to which hazards are covered are indicated in the scope of this standard.

It is assumed that:

- a) discussions take place between the manufacturer/supplier and purchaser/hirer about specific local installation conditions and expected duty;
- b) a risk analysis for each component that might be incorporated into a complete SAE installation has been made and rules have been drawn up;
- c) the safety requirements of this standard have been drawn up on the basis that the components are:
 - 1) designed in accordance with good engineering practice and calculation codes, including all failure modes;
 - 2) of sound mechanical and electrical construction;
 - 3) made of materials with adequate strength and of suitable quality;
 - 4) free of visible defects;
- d) harmful materials such as asbestos are not used;
- e) the equipment is maintained in good working order;
- f) any mechanical device manufactured in accordance with good practice and the requirements of this standard shall not be allowed to deteriorate to the point of creating a hazard without being detected;
- g) the working ambient temperature range is between -10 °C and $+55\text{ °C}$;
- h) the structure on which the SAE is installed is of adequate strength to resist the expected imposed loads.

When provisions of this type C standard are different from those which are stated in type A or B standards, the provisions of this type C standard take precedence over the provisions of the other standards, for machines that have been designed and built in accordance with the provisions of this type C standard.

1 Scope

1.1 Application

This European Standard specifies the requirements, test methods, marking and information to be provided by the manufacturer/supplier for suspended access equipment (SAE).

It is applicable to both permanent and temporary equipment which can be powered or hand operated and which are defined in Clause 3.

The requirements of this standard include the rails, tracks and other support systems on which SAE depend for their integrity and safety as well as taking into account all associated loads and fixings to the building structure.

This document is not applicable to SAE which is manufactured before the date of its publication as an EN.

1.2 Hazards

This European Standard deals with significant hazards pertinent to SAE when they are used as intended and under the conditions foreseen by the manufacturer (see Clause 4). This European Standard specifies appropriate technical measures to eliminate or reduce risks arising from the significant hazards.

1.3 Exclusions

The following are not covered in this document:

- a) operation in severe and special conditions (e.g. extreme environmental conditions, corrosive environments, strong magnetic fields);
- b) operation subject to special rules (e.g. potentially explosive atmospheres, work on live overhead electrical lines);
- c) transportation of passengers from one level to another;
- d) handling of loads which could lead to a dangerous situation (e.g. molten metal, acids/bases, radioactive materials);
- e) working platforms suspended by cranes;
- f) silo access equipment;
- g) SAE using chains for the direct suspension of a platform;
- h) SAE using fibre ropes for the suspension of a platform;
- i) SAE intended to be used underground;
- j) SAE intended to be used in shafts;
- k) SAE directly powered by combustion engines.

2 Normative references

The following documents, in whole or in part, are normatively referenced in this document and are indispensable for its application. For dated references, only the edition cited applies. For undated references, the latest edition of the referenced document (including any amendments) applies.

EN 795, *Personal fall protection equipment — Anchor devices*

EN 1993 (all parts), *Eurocode 3: Design of steel structures*

EN 1999 (all parts), *Eurocode 9: Design of aluminium structures*

EN 60204-1, *Safety of machinery — Electrical equipment of machines — Part 1: General requirements (IEC 60204-1)*

EN 60204-32:2008, *Safety of machinery — Electrical equipment of machines — Part 32: Requirements for hoisting machines (IEC 60204-32:2008)*

EN 60529, *Degrees of protection provided by enclosures (IP-code) (IEC 60529)*

EN ISO 4413, *Hydraulic fluid power — General rules and safety requirements for systems and their components (ISO 4413)*

EN ISO 4414, *Pneumatic fluid power — General rules and safety requirements for systems and their components (ISO 4414)*

EN ISO 12100:2010, *Safety of machinery — General principles for design — Risk assessment and risk reduction (ISO 12100:2010)*

EN ISO 13849-1:2008, *Safety of machinery — Safety-related parts of control systems — Part 1: General principles for design (ISO 13849-1:2006)*

EN ISO 13849-2:2012, *Safety of machinery — Safety-related parts of control systems — Part 2: Validation (ISO 13849-2:2012)*

EN ISO 13850, *Safety of machinery — Emergency stop — Principles for design (ISO 13850)*

3 Terms and definitions, symbols and abbreviations

For the purposes of this document, the terms and definitions given in EN ISO 12100:2010 and the following apply. They are classified in terms of key words.

3.1 building maintenance unit

BMU

SAE that are permanently installed on and dedicated to a specific building or structure and intended to be used for planned routine inspection, cleaning and maintenance of the particular building and where the general public might have access below the suspended platform when in operation

Note 1 to entry: BMUs may consist of a platform suspended from a suspension rig that is generally a trolley unit with hoist(s) operating either on a rail track or on a suitable running surface (e.g. concrete track).

Note 2 to entry: Monorails with traversing trolleys or other suspension rigs (e.g. davits) fixed to a building and from which a platform may be suspended should be considered as parts of a BMU and should only be used in conjunction with suspended platforms conforming to the requirements of this standard.

3.2 temporary suspended access equipment

TSAE

SAE systems that are temporarily installed on a building or structure in order to carry out specific construction tasks on a work site

EXAMPLE Work sites include cladding installation, painting, maintenance, repair and refurbishment of buildings, bridges, chimneys and other structures.

Note 1 to entry: TSAE may consist of a platform (TSP) and a suspension rig that are assembled at site prior to carrying out the task. TSAE are then dismantled and removed from site on completion of the work for which they were installed and may be reused elsewhere.

Note 2 to entry: Where a TSP is attached to a permanently installed suspension rig (e.g. roof trolley or monorail system) such installations are considered to be hybrid systems and the appropriate clauses of this document apply (see 12.6).

3.3 personnel

3.3.1 competent person

designated person, suitably trained, qualified by knowledge and practical experience and provided with the necessary instructions to carry out specified tasks safely

3.3.2 operator

designated person, suitably trained for working at height, qualified by knowledge and practical experience and provided with the necessary information to carry out operations safely from SAE

3.4 hoists and accessories

3.4.1 drum hoist

hoist with a drum on which the suspension ropes are reeled in one or more layers

3.4.2 traction hoist

assembly through which a wire rope is conveyed as a result of friction between the wire rope and the traction assembly with no tail load

3.4.3 twin capstan drum hoist

hoist system which lifts and lowers suspension rope(s) by passing the rope(s) around two gear driven grooved multi-wrap capstan drums and then to a wire rope winder designed to apply a tail load to the capstan drive system

3.4.4 jaw operated traction hoist

hoist where the traction assembly consists of two pairs of jaws

3.4.5 prime mover

source of power for the hoist

EXAMPLE This includes electric, hydraulic, pneumatic motors and hydraulic jacks.

3.4.6

rated speed

average speed measured during the upward and downward hoisting travel of a platform carrying its rated load for a travel length of 10 m or more and with the rated power supply applied

3.4.7

service brake

mechanical brake automatically applied by stored energy until released by an external sustained force, usually applied electrically, hydraulically or pneumatically, either under the control of the operator or automatically

EXAMPLE An example of stored energy is spring force.

3.4.8

secondary device

device intended to stop the descent of a platform under emergency conditions

EXAMPLE For example, breaking of a suspension wire rope or failure of a hoist.

3.4.8.1

fall arrest device

device acting directly on a secondary wire rope and which automatically stops and holds a platform in a fixed position

3.4.8.2

secondary brake

brake acting directly on a drum, traction sheave or final drive shaft and intended to stop the descent of a platform

3.4.9

anti-tilt device

device that detects when the longitudinal slope of a platform exceeds a pre-set angle

3.4.10

no-power descent

manually operated system that allows controlled descent of a power operated platform

3.4.11

manual lever/wheel/handle

device on the hoist that allows a platform to be lifted or lowered manually

3.4.12

wire (rope) winder

storage drum on to which a wire rope is reeled

3.4.13

cable reeler

storage drum on to which an electric cable is reeled

3.4.14

hoist operation cycle (for test purposes only)

one cycle that consists of lifting and lowering over a minimum vertical distance, this distance being where either

- the wire rope passes through all wire rope related parts of a traction hoist, its pulleys and reeler system, or
- the wire rope passes four turns around a drum hoist and its closely related pulleys

3.4.15

platform-mounted hoist

hoist that is mounted on a platform to raise and lower the suspended platform

3.4.16

roof-mounted hoist

hoist that is mounted on a suspension rig or trolley to raise and lower a suspended platform

3.4.17

materials (auxiliary) hoist

hoist that is mounted on a suspension rig or trolley to raise and lower other materials independently of a platform

3.4.18

overload detection device

device that trips and acts automatically to stop the upward motion of a platform if the load in the suspension wire ropes exceeds the tripping limit

3.4.19

tripping limit

static load that causes the overload detection device to operate

3.5

suspended platforms

3.5.1

suspended platform

that portion of SAE assembly designed to carry persons and their equipment

3.5.1.1

single point suspended platform

platform incorporating only one connection point

3.5.1.2

double point suspended platform

platform incorporating two connection points

3.5.1.3

multi-point suspended platform

platform incorporating three or more connection points and which is not hinged

3.5.1.4

hinged continuous platform

long platform incorporating more than two connection points and having articulated sections to ensure the correct tension is maintained in each suspension wire rope

3.5.1.5

multi-deck suspended platform

platform made up of two or more decks connected vertically

Note 1 to entry: See Figure 17.

3.5.1.6

cantilevered platform

platform where the deck extends beyond a connection point

3.5.1.7

suspended chair

chair that incorporates one connection point for one person only to use

3.5.2

restraint system

system connecting a suspended platform to mullions or fixed points on a building and which limits, whilst in use, the lateral movement of the suspended platform due to the wind

3.5.3

suspension wire rope restraint system

vertical series of attachment points on a building to which lanyards are connected to guide the suspension ropes of a suspended platform on descent and disconnected on ascent

Note 1 to entry: See Figure 18.

3.5.4

connection point

point provided on the platform or chair for the attachment of the hoist rope(s) or fall arrest device(s)

3.5.5

natural ground level

level from which the requirement for a platform restraint system is determined

3.6

loads

3.6.1

total suspended load

TSL

static load imposed on the suspension point(s) of a suspension rig comprising the rated load of the platform, the self-weight of the platform, the ancillary equipment, the wire ropes and the electric cable, if any

3.6.2

rated load

RL

rated load of persons and equipment that a suspended platform has been designated to carry by the manufacturer

3.6.3

working load limit

WLL

maximum load that a piece of equipment is authorized to sustain as designated by the manufacturer

3.6.4

hoist working load limit

HWLL

working load limit of a material hoist

3.6.5

working coefficient

arithmetic ratio between the maximum load designated by the manufacturer that a piece of equipment or SAE is able to hold and the WLL marked on the piece of equipment or SAE

3.6.6

test coefficient

arithmetic ratio between the loads used to carry out static or dynamic tests on a piece of equipment or SAE and the WLL marked on the piece of equipment or SAE

3.6.7

static test

test during which a piece of equipment or SAE is first inspected and then subjected to a force corresponding to the WLL multiplied by the appropriate static test coefficient and then re-inspected once the test load has been released to ensure that no damage has occurred

3.6.8

dynamic test

test during which the SAE is operated in all its possible configurations at its WLL, with account being taken of the dynamic behaviour of the SAE, in order to check that the SAE and its safety features are functioning correctly

3.6.9

hoisting cycle

sequence commencing when a platform is hoisted from the ground (or from the roof) and ending when the platform is returned to the starting position

3.7

steel wire ropes

3.7.1

calculated coefficient

ratio between the designated minimum breaking load of a steel wire rope and the maximum static load applied to that rope

3.7.2

minimum breaking load (of steel wire rope)

minimum breaking load of a steel wire rope as designated by the manufacturer

3.7.3

suspension rope

active steel wire rope carrying the suspended load

3.7.4

secondary rope

steel wire rope not normally carrying the suspended load but rigged to work in conjunction with a fall-arrest device

3.7.5

single active rope suspension system

two steel wire ropes attached to a suspension point, one rope being the suspension rope and the other being the secondary rope

3.7.6

double active rope suspension system

two steel wire ropes attached to one suspension point and sharing the suspended load

3.8

suspension rigs and track systems

3.8.1

suspension rig

portion of the SAE from which a platform is suspended

Note 1 to entry: This excludes the track system.

3.8.2

trolley

suspension rig mounted on wheels and designed to run on a track, runway or monorail to support a suspended platform

3.8.3

suspension point

designated position provided on a suspension rig assembly for the independent anchorage of the ropes, diverter pulleys or hoists

3.8.4

pivot point

device provided to equalize the loading imposed by the two suspension ropes of a double active rope suspension system

3.8.5

fulcrum

point or line about which the balancing moments of a suspension rig are calculated

3.8.6

stability coefficient

coefficient by which the overturning moment is multiplied

3.8.7

inboard portion

portion of a suspension rig that is on the building side of the fulcrum

3.8.8

outboard portion

portion of a suspension rig which projects from the fulcrum over the edge of a building

3.8.9

counterweights

weights that are attached to a suspension rig to counterbalance the overturning moments

3.8.10

counterweighted suspension beam

static beam where the stability is assured by counterweights

3.8.11

mechanically anchored suspension rig

suspension rig where stability is assured by mechanical anchors fixed to the building structure

3.8.12

stationary suspension rig

structure that is assembled and positioned before a platform is suspended from it

3.8.13

parapet clamp

structure attached to a roof parapet or similar static structure and dependent on the parapet for location and anchorage

Note 1 to entry: See Figure 13.

3.8.14

davit

structure fixed to a roof or similar static structure

Note 1 to entry: See Figure 12.

3.8.15

rail track

rails generally installed at roof level to support and guide a mobile suspension rig (trolley unit)

3.8.16

rail track support

braced or unbraced stanchion or cantilever supporting a rail track

3.8.17

sleeper

beam lying flat on a roof to support a rail track

Note 1 to entry: A sleeper is typically made of concrete or steel.

3.8.18

guide rail

rail generally installed at roof level to guide a mobile suspension rig (trolley unit)

3.8.19

monorail track

track generally fixed along the perimeter of a building to support and guide a mobile suspension rig (trolley unit)

3.8.20

lifting

operation that moves a suspended platform to a higher level

3.8.21

lowering

operation that moves a suspended platform to a lower level

3.8.22

platform rotation

circular horizontal movement of a suspended platform about a vertical axis passing through the platform itself

3.8.23

suspension rig slewing

circular horizontal movement of a suspension rig about a vertical axis

3.8.24

traversing

longitudinal horizontal movement of a suspension rig

3.8.25

luffing

rotational upward/downward movement of jib(s) about a horizontal axis to allow positioning of a suspended platform

3.8.26

jib telescoping

movement to extend or retract a jib to allow positioning of a suspended platform

3.8.27

jib slewing

circular movement of jib(s) about a vertical axis to allow positioning of a suspended platform

3.8.28

LW

vertical distance from the track to the centre of the area of the suspension rig affected by wind

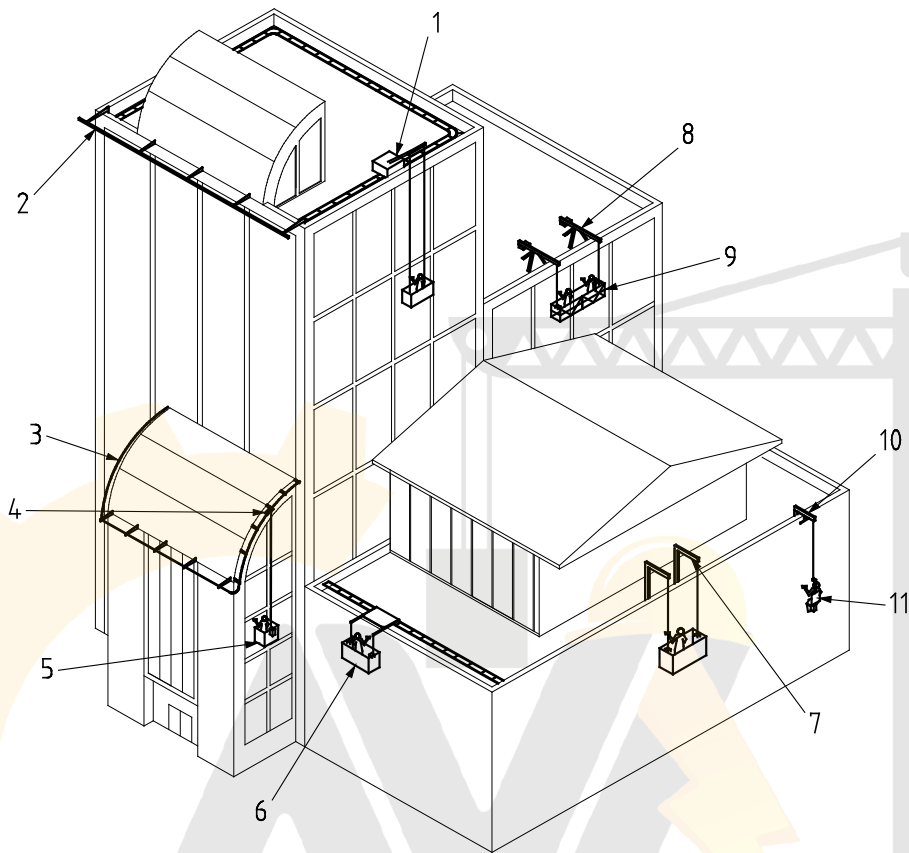

Key

- 1 roof trolley (BMU)
- 2 horizontal monorail
- 3 inclined monorail
- 4 monorail trolley
- 5 single point suspended platform
- 6 double point suspended platform
- 7 fixed davit
- 8 counterweighted suspension beam
- 9 suspended platform
- 10 parapet clamp
- 11 suspended chair

Figure 1 — Example of different types of SAE

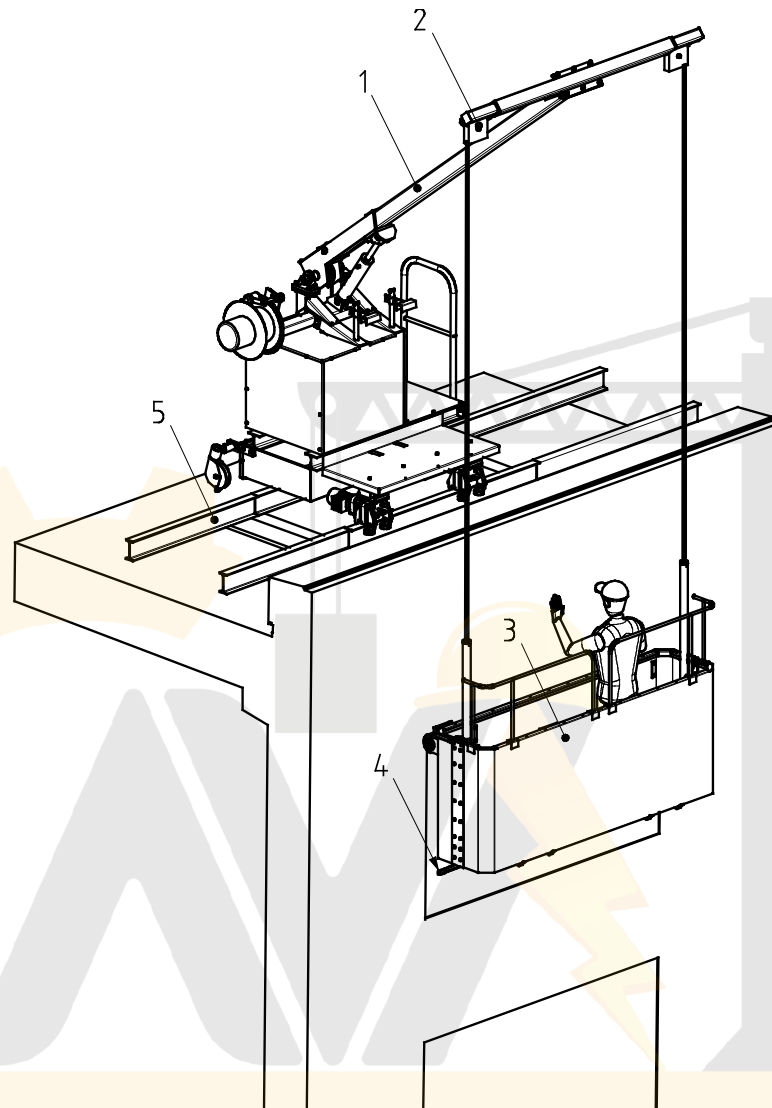

Key

- 1 luffing jib
- 2 pulley
- 3 suspended platform
- 4 obstacle device
- 5 track system

a) Typical BMU suspension rig on twin track (fixed or free laid)

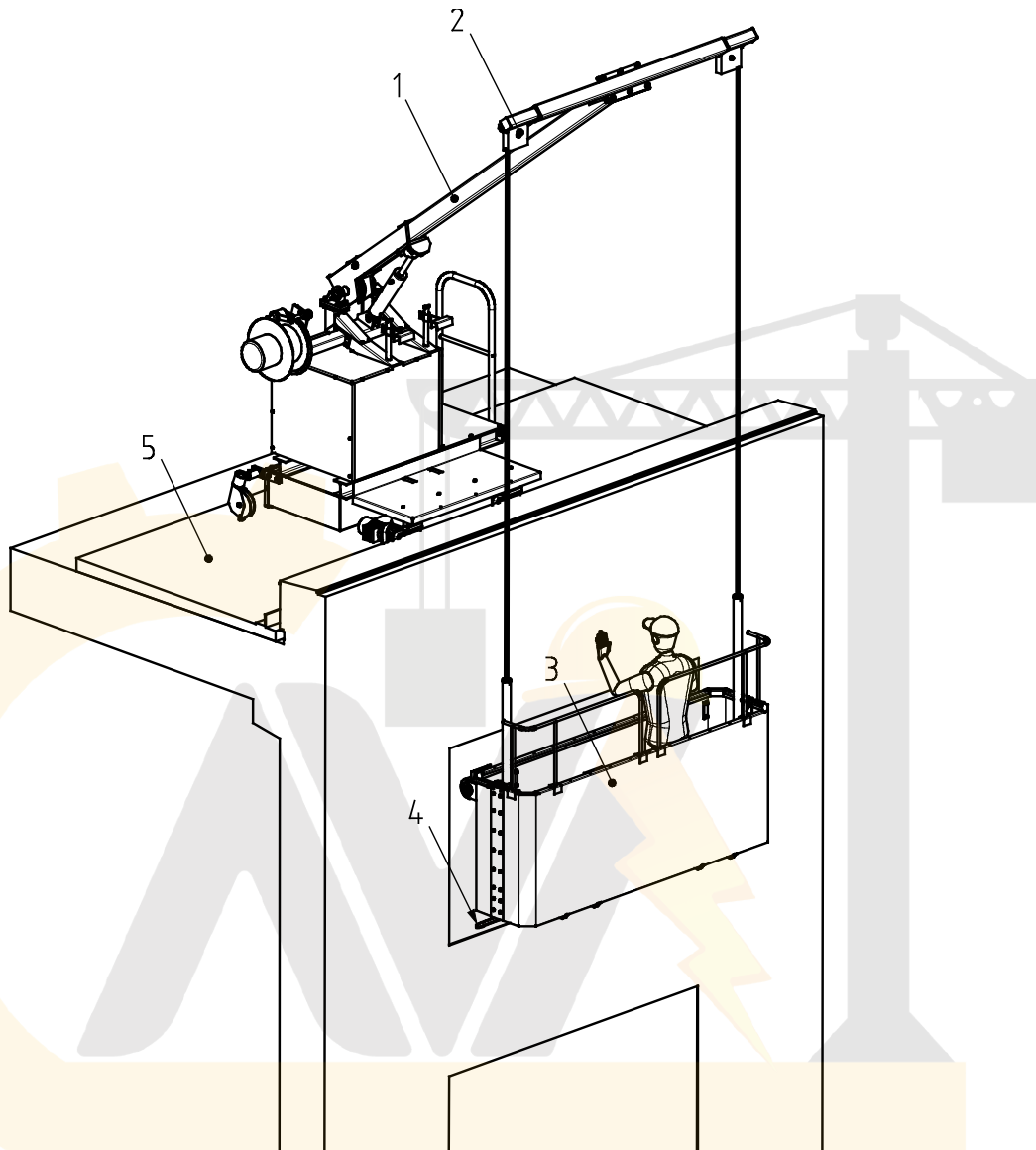

Key

- 1 luffing jib
- 2 pulley
- 3 suspended platform
- 4 obstacle device
- 5 roof or runway

b) Typical BMU suspension rig on concrete runway

Figure 2 — Examples of BMU suspension rigs (trolley units)

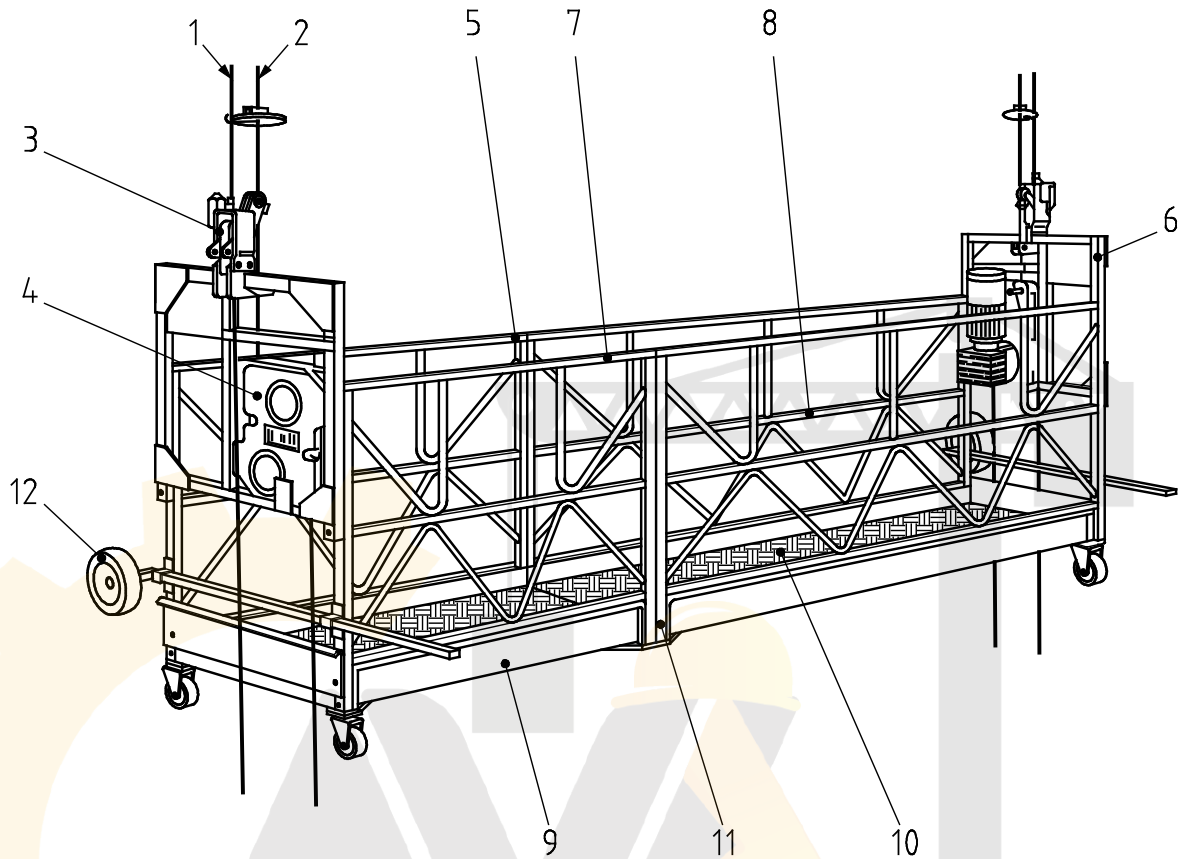

Key

- | | |
|------------------------|---------------------------|
| 1 secondary wire rope | 7 rear guard rail |
| 2 suspension wire rope | 8 intermediate guard rail |
| 3 fall arrest device | 9 toe board |
| 4 traction hoist | 10 decking |
| 5 front guard rail | 11 vertical member |
| 6 stirrup | 12 wall roller |

a) — Example of typical TSP platform

آریا ایمن آوات

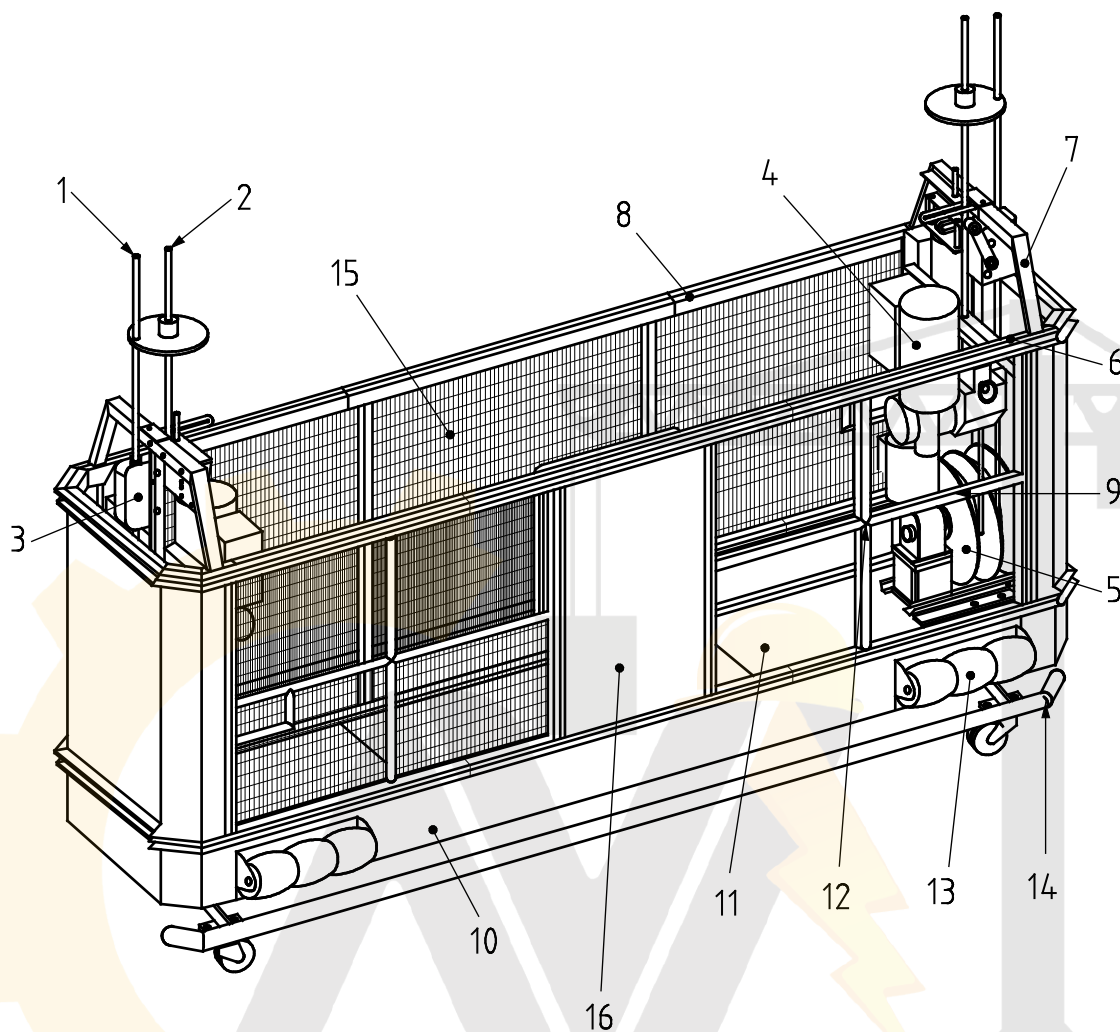

Key

1 secondary wire rope	9 intermediate guard rail
2 suspension wire rope	10 toe guard
3 fall arrest device	11 decking
4 traction hoist	12 vertical member
5 wire rope winder	13 soft rollers
6 front guard rail	14 obstacle device
7 stirrup	15 cladding or mesh
8 rear guard rail	16 control panel

b) Example of typical BMU platform with platform mounted hoists

Figure 3 — Examples of suspended platforms

NOTE Some of the cladding or mesh (Key 15) has been omitted from the figure to show the interior of the platform more clearly. For requirements for cladding or mesh, see 7.3.2.

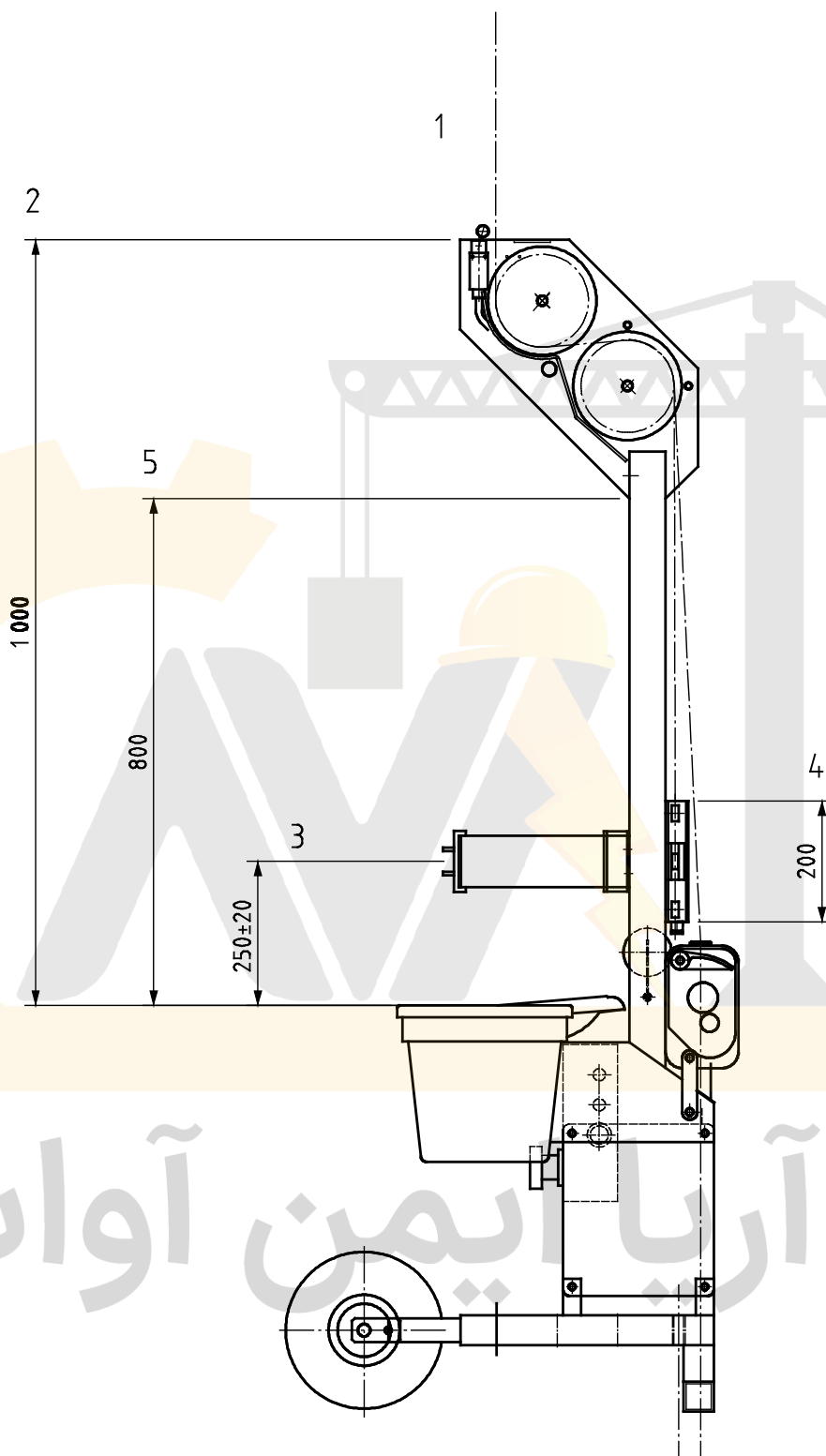

Key

- | | | | |
|---|--|---|--|
| 1 | wire ropes | 4 | minimum width of back support |
| 2 | minimum distance between seat and top sheave | 5 | minimum distance between seat and sheaving |
| 3 | position of back support and restraint belt | | |

a) Typical SAE single-point suspended chair

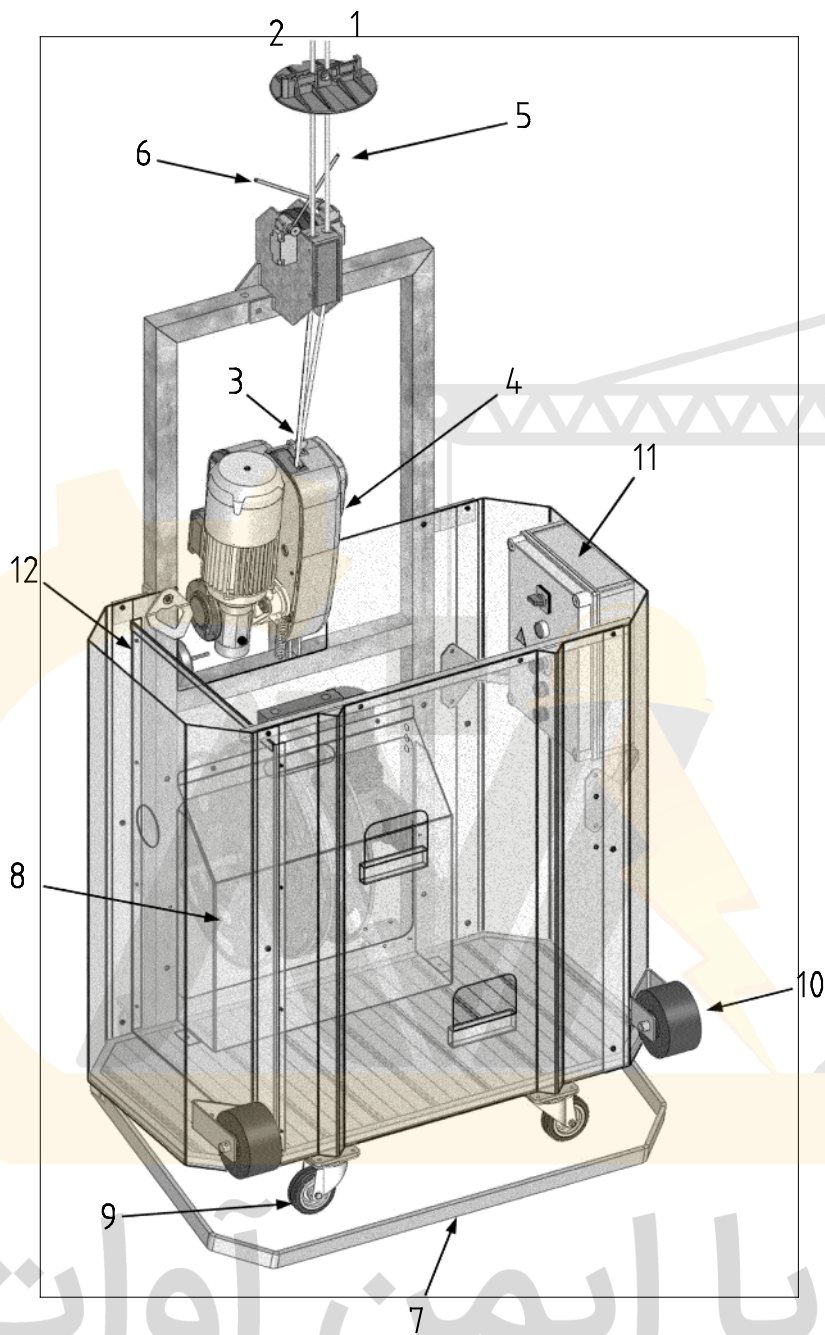

Key

- | | | | |
|---|---------------------------------|----|------------------|
| 1 | striker plate (top limit plate) | 7 | obstacle device |
| 2 | suspension/secondary ropes | 8 | wire rope reeler |
| 3 | traction hoist | 9 | castor wheel |
| 4 | fall arrest device | 10 | wall roller |
| 5 | top limit switch | 11 | control box |
| 6 | ultimate top limit switch | 12 | cladding |

b) Typical SAE single-point suspended platform

Figure 4 — Example of typical single-point suspended chair and suspended platform

3.9 Symbols and abbreviations

A	Area exposed to wind	(m ²)
a	Deflection of the platform under load	(mm)
B	Width of the platform	(m)
b	Residual deflection of the platform	(mm)
BMU	Building maintenance unit	(-)
C	Shape factor	(-)
C _{wr}	Working coefficient for suspension rig	(-)
D	Pitch diameter of pulley or drum hoist	(mm)
F	Force	(N)
F _h	Horizontal force	(N)
F _o	Minimum designated breaking load of wire rope	(N)
F _v	Vertical force	(N)
F _s	Shearing force	(N)
F _{w1}	Wind force in service	(N)
F _{w2}	Wind force out of service	(N)
F _{wMH}	In-service wind force on material	(m ²)
H	Pitch ratio	(-)
HSW	Mass of all suspended materials hoist items	(kg)
HWLL	Hoist working load limit	(kg)
L	Length of platform	(m)
L _b	Distance between the fulcrum and the point where the self-weight of the suspension rig acts	(m)
L _c	Length of cantilevered section of platform	(m)
L _f	Free span of guard rail between two vertical members	(m)
L _i	Length of inboard portion of suspension rig	(m)
L _o	Length of outboard portion of suspension rig	(m)
L _{pi} /L _{po}	Horizontal projection between the fulcrum line and the point where SWP/W acts	(m)

Ls	Distance between the bolts or supports which withstand the overturning moment	(m)
Lmi/Lmo/Lsl/Lw/Lshml	Horizontal projection between the fulcrum and the point where SL, Mi, Mo, Fw and TSHML act	(m)
Mc	Mass of electric cable	(kg)
Me	The weight of personal equipment	(kg)
Mi	Mass of inboard portion of suspension rig	(kg)
Mm	Mass of material on work platform	(kg)
Mo	Mass of outboard portion of suspension rig	(kg)
Mp	Assumed mass of a person	(kg)
Mw	Mass of the counterweights	(kg)
Mwr	Mass of wire ropes when the platform is completely lowered	(kg)
N	Number of persons on the platform	(–)
Nr	Number of steel wire ropes or falls supporting the platform	(–)
Q	Wind pressure	(N/m ²)
Ra	Standard of smoothness	(μm)
RF	Minimum load capacity of platform deck	(kg/m ²)
Rh	Horizontal support reaction on suspension rig	(N)
RL	Platform rated load	(kg)
RLMH	Rated load material hoist	(kg)
Rv	Vertical support reaction on suspension rig	(N)
S	Maximum static force in a wire rope	(N)
Sa	Surface area of deck	(m ²)
SAE	Suspended access equipment	(–)
Sd	Shock load coefficient	(–)
SWR	Mass of a suspension rig (self-weight of rig)	(kg)
SWP	Mass of a platform (self-weight of platform)	(kg)
T	Length over which the load is distributed	(m)
Tm	Maximum traction force in the wire rope	(N)
TSHL	Total suspended hoist load	(kg)

TSL	Total suspended load	(kg)
TSP	Temporary suspended platform	(–)
V	Wind speed	(m/s)
W	Safe working load on the cantilevered deck	(kg)
WLL	Working load limit	(kg)
Wtd	Dynamic test load	(kg)
Wts	Static test load	(kg)
Zp	Calculated coefficient of steel wire rope	(–)
σ_E	Elastic yield limit	(N/mm ²)
σ_R	Ultimate limit	(N/mm ²)
σ_a	Allowable stress	(N/mm ²)
VE	Safety coefficient compared to elastic yield limit	(–)
VR	Safety coefficient compared to breaking limit	(–)

4 Hazards and preventative actions

This clause lists hazards and hazardous situations identified by risk assessments as being significant for SAE and which require action to eliminate or reduce the risk.

A hazard that is not relevant (NR), not significant (NS) or not dealt with in this standard (ND) is shown in the corresponding requirements column of Table 1.

Table 1 — List of hazards

Line No.	Hazards	Relevant clauses in this standard
1	Mechanical hazards:	
1.1	Generated by machine parts or work pieces caused by:	
1.1.1	Shape	9.4.1
1.1.2	Mass and stability (potential energy of elements which might move under the effect of gravity)	see Item 27.1.1 of this table
1.1.3	Inadequacy of mechanical strength	see Item 27.4 of this table
1.2	Accumulation of energy inside the machinery caused by:	
1.2.1	Elastic elements (e.g. spring loaded wire rope winder)	14.2.6
1.2.2	Liquids and gases under pressure	10.6
1.3	Elementary forms of mechanical hazards:	
1.3.1	Crushing hazard due to lack of clearance	Introduction, 9.3.2, 14.2.3

Line No.	Hazards	Relevant clauses in this standard
1.3.2	Shearing hazard	8.1.4, 8.10.6
1.3.3	Cutting or severing hazard	8.1.4, 8.10.6
1.3.4	Entanglement hazard	8.1.4
1.3.5	Drawing in or trapping hazard	8.3.4.5
1.3.6	Impact hazards due to swinging of the platform against the facade	7.7, 7.8
1.3.7	Stabbing or puncture hazard	NS
1.3.8	Friction or abrasion hazard	NS
1.3.9	High pressure fluid injection or ejection	10.6
2	Electrical hazards:	
2.1	Contact of persons with live parts (direct contact) shall be considered in relation to the degree of protection	10.6
2.2	Contact of persons with parts which have become live under faulty conditions (indirect contact) shall be considered in relation to: — main power supply protection — continuity of the protective bonding circuit	10.3 14.2.3
2.3	Approach to live parts under high voltage	ND
2.4	Electrostatic phenomena	NR
2.5	Thermal radiation or other phenomena such as the projection of molten particles and chemical effects from short circuits, overloads, etc.	NS
3	Thermal hazards resulting in burns by possible contact with persons	NS
4	Hazard generated by noise	9.2.5.1
5	Hazard generated by vibration	NS
6	Hazard generated by radiation	ND
7	Hazard generated by materials and substances	ND
8	Hazard generated by neglecting ergonomic principles in machinery design as hazards from:	
8.1	Unhealthy postures or excessive effort: — minimum free height — maximum force applied to a crank or lever — maximum weight of portable components	7.5.3 8.2.2, 8.2.3 9.4.2
8.2	Inadequate consideration of hand-arm or foot-leg anatomy: platform dimensions	7.1
8.3	Neglected use of personal protection equipment	14.2.5
8.4	Inadequate local lighting	14.2.5
8.5	Overload and underload	14.2.5
8.6	Human error, human behaviour Unintentional command by the operator Assembly of modular platforms using fool-proof connections	11.1 11.2, 11.3, 11.4 7.2.1
9	Combination of hazards	ND
10	Unexpected start-up, unexpected overrun/overspeed:	
10.1	Failure/disorder of the control system can result:	11.4

Line No.	Hazards	Relevant clauses in this standard
	— in being trapped on the platform — in unintentional movement	11.4
10.2	Restoration of energy supply after interruption	11.4
10.3	External influences on electrical equipment	10.6, 11.4
10.4	Other external influences	14.2.5
10.5	Error in the software	11.4
10.6	Errors made by the operator (due to mismatch of machinery with human characteristics and ability)	NR
11	Impossibility of stopping the machine in a safe condition	5, 8.1.6, 8.3.2, 11.1, 11.2, 14.2.5
12	Variations in the rotational speed of tools	NR
13	Failure of the power supply	8.3.4
14	Failure of the control circuit	11.4
15	Errors of fitting	7.2.1, 14.2.3
16	Break-up during operation	11.4, 14.2.5
17	Falling or ejected objects or fluid	7.1
18	Loss of stability/overturning of machinery	See Item 27.1.1 of this table
19	Slip, trip and fall of persons	See Item 27.2 of this table
Additional hazards and hazardous events due to mobility:		
20	Relating to the travelling function:	
20.1	Excessive speed of pedestrian controlled machinery	9.3.3
20.2	Excessive oscillation of platform when moving	9.3.3, 9.3.4, 9.3.5
20.3	Insufficient ability of machinery to be slowed down, stopped and immobilized	8.1.6, 8.3.2, 8.3.3, 9.3.3
21	Linked to work position:	
21.1	Fall of persons during access to the work position	Introduction, 9.3.2, 9.3.8
21.2	Mechanical hazards at the work position: — contact with the wheels — contact of persons with machine — pedestrian controlled machines	9.3.2 9.3.2 9.3.3
21.3	Insufficient visibility from work position	ND
21.4	Inadequate seating	7.6
22	Due to the control system:	
22.1	Inadequate location of controls/control devices	11.3, 11.4
23	From handling the machine, lack of stability	14.2.2
24	Due to the power source and to the transmission of power:	
24.1	Hazards from the batteries	9.2.5.3

Line No.	Hazards	Relevant clauses in this standard
25	From/to third parties:	
25.1	Unauthorized start-up/use	9.3.6, 11.3, 11.4, 14.2.5
25.2	Lack or inadequacy of visual or acoustic warning means	8.3.5.7, 9.3.3, 13
26	Insufficient instructions for the operator	14.2.5
Additional hazards and hazardous events due to lifting of the platform:		
27	Mechanical hazards and hazardous events:	
27.1	Hazards due to falling caused by:	
27.1.1	Lack of stability due to: <ul style="list-style-type: none"> — an excess of overhang — an insufficient quantity of counterweights — counterweights not properly located and fixed — insufficient strength of building structure 	13.5 6.5 9.3.6 Introduction, 14.2.3
27.1.2	Uncontrolled loading - overloading - overturning moments exceeded due to: <ul style="list-style-type: none"> — unknown weight of load 6.5.2, 8.3.5 — under-hooking of the platform 8.3.9, 11.4 — interaction of two or more hoists with unequal load distribution on platform 8.3.5.2 — load self-oscillation in the rope by rapid switching of UP/DOWN controls 11 	6.5.2, 8.3.5, 8.3.9, 11.4, 8.3.5.2, Clause 11
27.1.3	Uncontrolled amplitude of movements	7.7, 8.3.10, 9.2.2
27.1.4	Unexpected/unintended movements of loads	6.5.2, 8.9.2
27.1.5	Inadequate holding devices/accessories	6.5.2, 8.1.6, 8.3.2, 8.3.3
27.2	From lifting of persons and hazards due to falling shall be considered in relation to:	
27.2.1	Decking, sides guard rails and toe boards of platform	7.1
27.2.2	Control of the platform level	8.3.8, 8.9.3.9
27.2.3	Safe access to equipment	Introduction, 7.4
27.2.4	Safe access to the wire rope anchorage points	14.2.3
27.2.5	Falling objects from the platform	7.1, 7.2.3
27.2.6	Objects falling on to the platform	7.1.5
27.3	From derailment	9.3.1
27.4	From inadequate mechanical strength of parts	6
27.5	From inadequate design of pulleys, hoists etc.	8
27.6	From inadequate selection/integration into the machine of chains, ropes, lifting accessories	9
27.7	From lowering of the load by friction brake	8.1.6

Line No.	Hazards	Relevant clauses in this standard
27.8	From abnormal conditions of assembly/testing use/maintenance or mixing of components	14.2
27.9	From load-person interference (impact by load)	9.3.6
28	Electrical hazard:	
28.1	From lightning	14.2
29	Hazards generated by neglecting ergonomic principles:	See Item 8.1 of this table
29.1	Insufficient visibility for the operator	NS
30	Hazards due to hoisting of material	
30.1	Load falling on to persons on the platform	6.5.2, 8.12
30.2	Wind on the load	6.5.2, 8.12
30.3	Overload	6.5.2, 8.12
30.4	Material not in a vertical line with the material hoist	6.5.2, 8.12
30.5	Stability	6.5.2, 6.5.4.1, 6.5.4.2, 8.12

5 Safety requirements and/or measures

All SAE shall comply with the safety requirements and/or protective measures in Clause 6 to Clause 14 of this standard. In addition, the machine shall be designed according to the principles of EN ISO 12100 for relevant but not significant hazards, which are not dealt with by this document.

During the design of SAE appropriate provisions shall be made for their safe use. These provisions shall include recommendations for rescue.

NOTE See 14.1.

6 Structural, stability and mechanical calculations for SAE

6.1 General

The design calculations for all SAE shall be carried out in accordance with European codes and engineering practices including, if necessary, the effects of elastic deformations. All failure modes of materials shall be considered including fatigue and wear.

In the absence of a harmonized standard relevant FEM (European Federation of Materials Handling) rules for the method of calculation of lifting equipment should be referred to. The load cases are specified in the following standards:

- FEM 9.511, Rules for the design of series lifting equipment: Classification of mechanisms;
- FEM 9.341, Rules for the design of series lifting equipment: Local girder stresses;
- FEM 1.001, Rules for the design of hoisting appliances, booklet 2: Classification and loading on structures and mechanisms;
- FEM 1.001, Rules for the design of hoisting appliances, booklet 3: Calculating the stresses in structures;

- FEM 1.001, Rules for the design of hoisting appliances, booklet 4: Checking for fatigue and choice of mechanism components.

The design calculations may be carried out in accordance with the permissible stress method. If the limit state method is used it shall result in the same level of safety.

6.2 Safety margin allowed within the calculations

6.2.1 Calculating the stresses in structures

6.2.1.1 General

See also FEM 1.001 booklet 3.

For the three load cases defined in Table 2 and Table 3 the calculation of the different members is set out allowing a safety margin for the critical stresses. Taking the three common failure modes into account:

- yield strength exceeded;
- critical load for buckling exceeded;
- fatigue limit exceeded.

6.2.1.2 Allowable stresses

For carbon and stainless steels where the ratio between the elastic yield limit σ_E and the breaking limit σ_R is less than 0,7 refer to Table 2. Where the ratio is higher than 0,7 refer to FEM 1.001 booklet 2.

For aluminium, refer to Table 3.

The calculated stress shall not exceed the allowable stress σ_a obtained by dividing σ_E by a coefficient depending on the load cases set out in Table 2 and Table 3.

Load case 1: In-service conditions (i.e. SAE with RL, in-service wind)

Load case 2a: Occasional conditions (e.g. static and dynamic tests, tripping of overload detection device)

Load case 2b: Occasional conditions (e.g. out-of-service storm wind)

Load case 3: Extreme conditions (e.g. operation of the secondary device)

Table 2 — Value of v_E (Carbon steel and stainless steel)

	Load case 1	Load cases 2a and 2b	Load case 3
Value of v_E	1,5	1,33	1,1
Allowable stress σ_a	$\sigma_E / 1,5$	$\sigma_E / 1,33$	$\sigma_E / 1,1$

For the allowable stresses in welded steel structures, see EN 1993 (all parts) (*Eurocode 3*).

Table 3 — Value of v_E (Aluminium)

	Load case 1	Load cases 2a and 2b	Load case 3
Value of v_E	1,65	1,46	1,15
Allowable stress σ_a	$\sigma_E / 1,65$	$\sigma_E / 1,46$	$\sigma_E / 1,15$
AND (*)	$\sigma_R / 2,2$	$\sigma_R / 2$	$\sigma_R / 1,5$

For the allowable stresses in welded aluminium structures, see EN 1999-1-1 (*Eurocode 9*).

For extruded aluminium profiles the breaking limit is in general very close to the elastic yield limit and both conditions should therefore be satisfied.

6.2.1.3 Checks against fatigue

For SAE structures subject to fatigue the minimum number of cycles and load spectrum to take into account are set out in Table 4.

Table 4 — Parameters for checking against fatigue

Group of structure of the SAE	Number of hoisting cycles n max	Load spectrum factor Kp
A2 (U1 / Q3)	30 000	0,5
A3 (U1 / Q4)	30 000	1
A4 (U2 / Q4)	60 000	0,5
A4 (U2 / Q4)	60 000	1

6.2.2 Calculating the stress in mechanisms

6.2.2.1 General

The calculated stress shall not exceed the allowable stress derived from Table 5, using the breaking stress of the material.

The value of the allowable stress σ_a is given by the following formula:

$$\sigma_a = \frac{\sigma_R}{V_R}$$

Table 5 — Parameters for checking against breaking

	Load case 1	Load cases 2a and 2b	Load case 3
Value of v_R	4	2,2	1,5
Allowable stress σ_a	$\sigma_R/4$	$\sigma_R/2,2$	$\sigma_R/1,5$

6.2.2.2 Checks against fatigue and wear

For mechanical parts subject to fatigue and wear (except for surfaces in contact with wire ropes) the minimum number of operating hours and load spectrum to take into account are set out in Table 6.

Table 6 — Parameters for checks against fatigue and wear

Group of mechanism of the SAE	Total operating time (hours) T	Load spectrum factor
M4 (T2 / L4)	500	1
M6 (T4 / L4)	2 000	1

NOTE Refer to FEM 1.001 booklets 2 and 4.

6.3 Design loads and forces

6.3.1 General

The rated load (RL) of the SAE and the maximum number of persons (n) permitted on the SAE are to be stated by the manufacturer or supplier (see 3.6.2).

The WLL of each hoist shall be equal to or greater than the vertical reactions transmitted by the portion of suspended platform and the load suspended by that hoist.

All suspended loads should be taken into account (i.e. including power and suspension cables, tension weights on secondary suspension cables).

6.3.2 TSAE Compatibility

Since some TSAE incorporating platform mounted hoists are modular the WLL of the suspension rig and its accessories shall be equal to or greater than the WLL of the hoists plus the reaction transmitted by the weight of the safety ropes, tension weights and the power cable.

6.3.3 De-rating the WLL of hoist(s)

The WLL of hoists may be de-rated by the manufacturer or his appointed representative, providing the condition in 6.3.2 is satisfied.

The following steps shall be taken to de-rate a hoist:

- a) The hoist overload detection device shall be adjusted to trigger at a maximum of 125 % of the de-rated load.
- b) Additional safety devices shall be incorporated to set the de-rated load. Such additional devices could consist of one or more of the following:
 - 1) a current overload device which shall be set to stop the hoist motor at a maximum of 150 % of the de-rated WLL;
 - 2) thermal overload device which shall be set to stop the hoist motor at a maximum of 150 % of the de-rated WLL;
 - 3) the stalling load of the motor shall be less than 2,5 times the de-rated WLL of the hoist;
 - 4) a torque limiting device that shall be set to halt the raising/lowering of the platform if a load of 150 % of the de-rated WLL is applied to the hoist.
- c) The hoist shall be clearly marked with the de-rated WLL.

If the only action taken to decrease the WLL of a hoist is that as described in 1) above then the hoist is not regarded as being de-rated and the suspension rig calculations for mechanical strength and the amount of counter-weight needed should still use the WLL of the hoist as specified and certified by the manufacturer.

NOTE 1 For testing the hoist stalling load see B 1.6.

NOTE 2 For the purpose of calculations of SAE covered by this standard it is considered that a mass of 1 kg produces a force of 10 N.

6.3.4 Rated load on the platform

6.3.4.1 Platform for one person

$$RL = Mp + Me + Mm \quad (\text{Minimum RL} = 120 \text{ kg}) \quad (1)$$

Platform for two or more persons:

$$RL = (n \times Mp) + (2 \times Me) + Mm \quad (\text{Minimum RL for two person platform} = 240 \text{ kg}) \quad (2)$$

where

$Mp = 80 \text{ kg};$

$Me = 40 \text{ kg};$

Mm can be 0 kg or a specified figure.

NOTE 1 A maximum of two persons only are considered for Me .

NOTE 2 The calculation of the RL applies to all types of platforms covered by this standard.

6.3.4.2 Minimum load capacity

The minimum load capacity of the deck (RF) shall be 200 kg/m^2 .

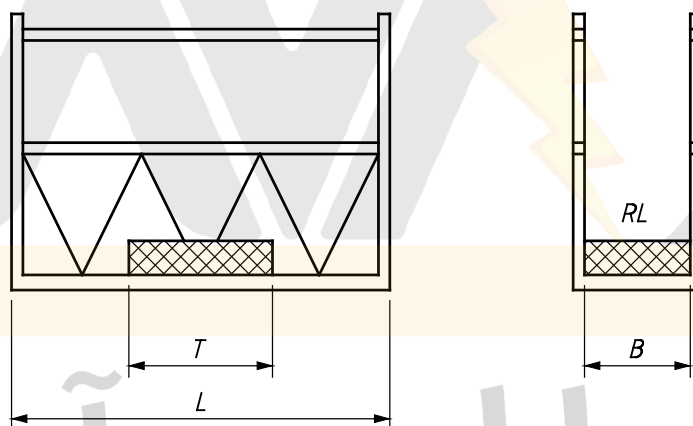

Figure 5 — RL distribution

6.3.4.3 Calculation of RL

The RL is calculated in accordance with the formulae (1) or (2) and distributed over a surface area Sa located on a length T :

$$Sa = B \times T \quad (3)$$

$$T = \frac{RL}{B \times RF} \quad (4)$$

6.3.4.4 Single point suspended platform or chair

The minimum RL shall be 120 kg.

6.3.4.5 Two point suspended platform

6.3.4.5.1 To prove the strength of the platform the RL, distributed over a length T, is assumed to be applied in the most unfavourable position.

6.3.4.5.2 If a two point suspended platform extends beyond a suspension point a stability coefficient against overturning of 2 shall be applied to the load (W) located on the cantilevered section of the platform to ensure adequate stability.

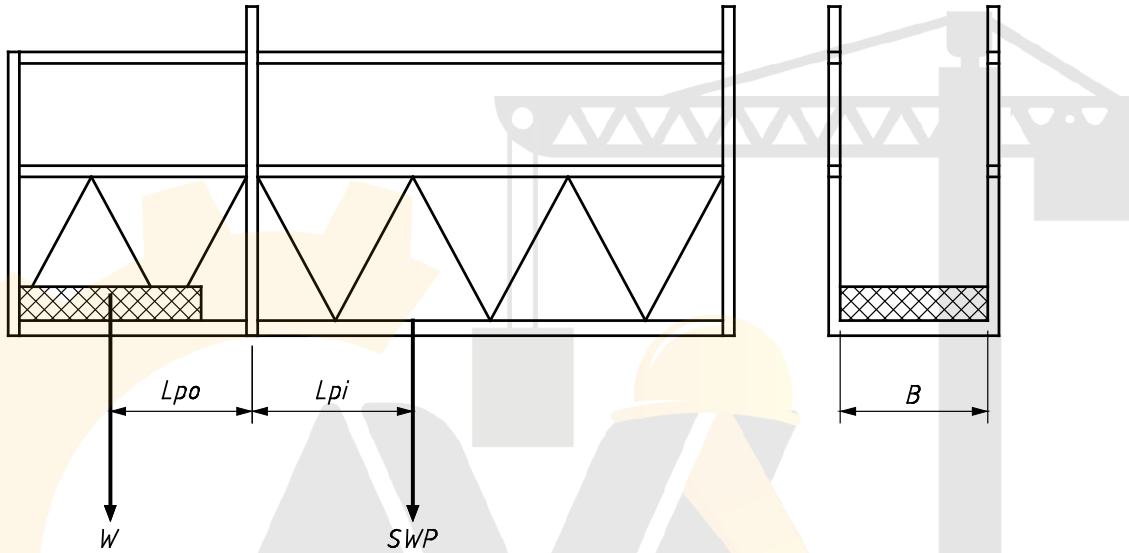

Figure 6 — Cantilevered platform

Calculation for example in Figure 6:

$$SWP \times Lpi \geq 2 \times W \times Lpo \tag{5}$$

$$W = Sa \times RF \leq RL \tag{6}$$

where

W shall be not less than 120 kg.

6.3.4.6 Multi-point suspended platform and hinged continuous platform

6.3.4.6.1 The RL is calculated in accordance with the Formulae (1) or (2) and distributed over a surface area Sa as shown in Figure 5.

6.3.4.6.2 For a wide work platform where T < B as shown in Figure 7 Sa is a square area with a side dimension equal to:

$$T = \sqrt{\frac{RL}{RF}} \tag{7}$$

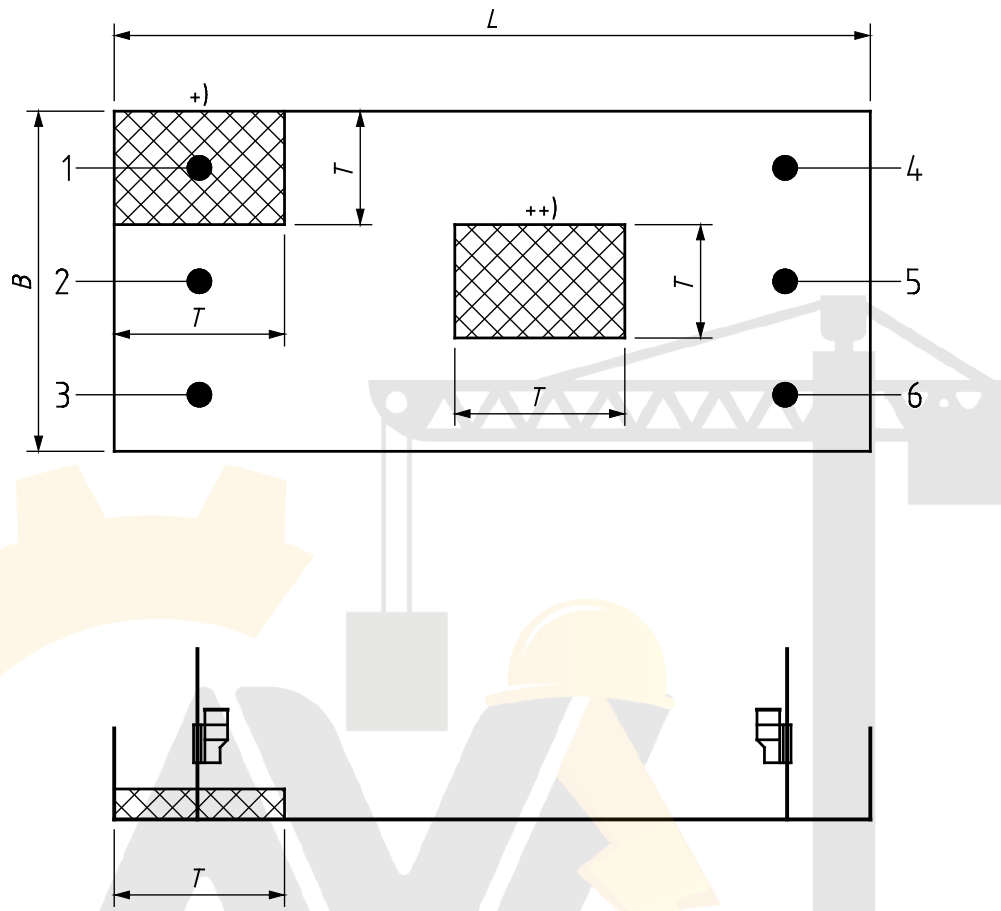

Key
1-6 suspension points

Figure 7 — Example of multi-point suspended platform

NOTE In Figure 7 the location of the load in position +) is used for the calculation of the force S in the suspension wire ropes. The location of the load in position ++) is used for the calculation of the strength of the platform.

6.3.4.6.3 For a hinged continuous platform the RL shall be assumed to apply at the most unfavourable position as shown in Figure 8.

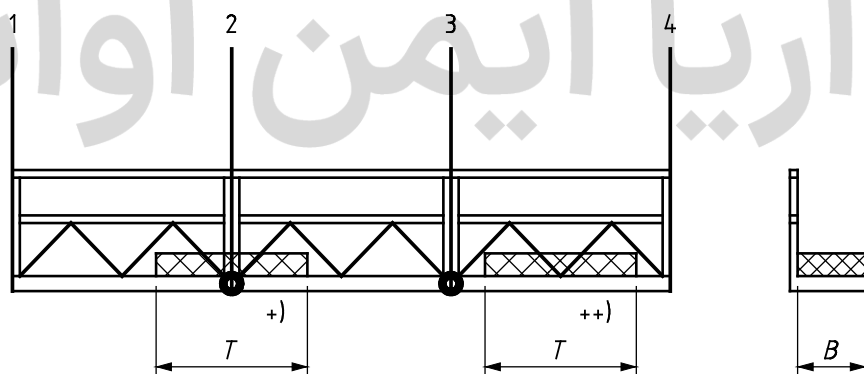

Key
1-4 suspension wire ropes

Figure 8 — Example of hinged continuous platform

NOTE In Figure 8 the location of the load in position +) is used for the calculation of the force S in the suspension wire ropes. The location of the load in position ++) is used for the calculation of the strength of the platform.

6.3.5 Wind loads

6.3.5.1 Design wind speeds in accordance with Table 7 that should be considered for all SAE likely to be affected by wind when in service.

Table 7 — Wind pressure

Wind pressure in operation q (N/m ²)	Wind speed v (m/s)
Non-guided platforms = 125	14
Continuously guided platforms = 250	20

NOTE For shape factors applied to areas exposed to wind refer to FEM 1.001 booklet 2.

These wind speeds are the designed wind speeds for SAE. They do not represent the safe wind speeds for SAE when in service.

6.3.5.2 The full exposed area of one person standing on an open TSP platform is 0,7 m² with the person's effective centre of area 1 m above the platform floor.

The exposed area of one person standing on a TSP or BMU platform behind a clad section of the platform is 0.35 m² with the persons effective centre of area 1,45 m above the platform floor.

For the purposes of calculation the assumed exposed surface area of any material on a platform is 2 m².

6.3.5.3 Wind loads are assumed to act horizontally at the centre of the area of the component parts of SAE.

6.3.5.4 The wind loads acting on a platform shall be considered to be acting on the suspension points of the associated suspension rig.

6.3.5.5 For BMUs an additional calculation is needed for storm force winds with the machine in the parked position.

Table 8 — Storm wind

Intended height above ground (m)	Wind speed v (m/s)	Wind pressure q (N/m ²)
0 to 20	36	800
20 to 100	42	1 100
100 to 150	46	1 300
> 150	to be considered in accordance with local conditions (guidance can be obtained from EN 12158-1:2000+A1:2010, Annex A, building wind tunnel tests or the building structural engineer)	

6.3.5.6 Calculations shall be used to prove that a suspension rig will not move by wind forces alone, whether in service or in the parked position, when the service brake(s) have been applied. Where storm wind forces can move a suspension rig an anchoring device shall be provided at the parking position.

Calculations shall also be used to prove that jib(s) will not slew by wind forces alone, whether in service or in the parked position, when the service brake(s) have been applied. Where storm wind forces can move jib(s) an out-of-service anchoring device shall be provided.

6.3.6 Forces exerted by persons

6.3.6.1 The minimum value to be used for the forces exerted by persons on the guardrails or top edge of a rigid side of a platform is assumed to be 200 N for each of the first two persons on the platform and 100 N for each additional person, these forces acting in the horizontal direction at 500 mm intervals.

6.3.6.2 The guardrail or top edge of a rigid side of a platform shall be able to resist, without permanent deflection, a vertical load of 1 kN applied at the most unfavourable position.

6.3.6.3 The mesh or cladding of a platform shall not fail when a horizontal force of 200 N distributed over an area of 100 × 100 mm is applied at any location on the surface.

6.4 Platform structural calculations

The strength of the platform is to be proven by calculation for the load cases expressed below:

Load case 1:	$1,25 \times (RL + SWP)$	(see 6.3.4)
	+ $1,25 \times$ Wind loads in operation	(see 6.3.5)
	+ $1,25 \times$ Forces exerted by persons	(see 6.3.6)
Load case 2:	$1,5 \times RL + SWP$	
Load case 3 (TSP):	(e.g. triggering of the fall arrest device)	$2,5 \times (RL + SWP)$
Load case 3 (BMU):	(e.g. triggering of the fall arrest device)	$0,8 \times S_d \times (RL + SWP)$

(Where S_d is shock load coefficient as derived in B.1.4 and B.1.5).

Load case 3 (TSP & BMU): (e.g. collision of the platform with an obstruction) when lifting, see Figure 9 or lowering, see Figure 10)

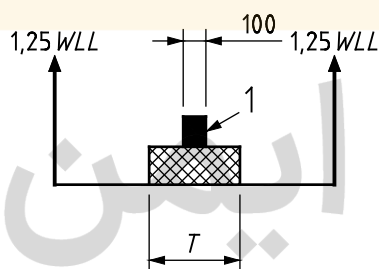

Key

1 obstruction 1

Figure 9 — Obstruction when lifting

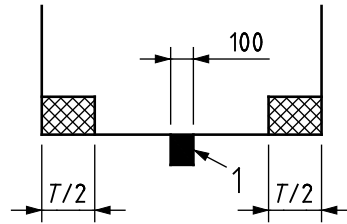

Key

1 obstruction 1

Figure 10 — Obstruction when lowering

The obstruction 1 shall be placed in the most unfavourable position.

NOTE The lifting force is assumed to be equal to $1,25 \times \text{WLL}$ of the hoist(s).

SWP should take into account the mass of wire rope winders, if installed.

6.5 Calculations for suspension rigs

6.5.1 General

Suspension rigs shall be designed and constructed to withstand the loads derived from the static and dynamic tests and any additional dynamic loads caused by a failure of a hoist or suspension wire rope.

In addition to having stability against overturning, suspension rigs should have sufficient lateral strength or be braced against the effects of lateral sway of the platform parallel to the face of the building or structure.

The forces producing lateral sway can be caused by wind, movement of the platform or surges caused by the starting and stopping of the traversing system.

Reaction forces for all SAE shall be calculated and the results given to the structural engineer responsible for the building or structure. This information should include the results of Load cases 1 and 2b and the stability calculations.

6.5.2 SAE incorporating auxiliary material hoist

Stability and strength calculations of the machine, including the materials hoist, to be performed in accordance with Table 9 or Table 10 and Table 11 or Table 12.

6.5.3 Structural calculations for suspension rigs

6.5.3.1 Structural calculations for BMU suspension rigs

The strength of BMU suspension rigs with either roof or platform-mounted hoists shall be proven by calculations for the load cases given in Table 9 (see Figure 11).

Table 9 — Load cases for BMU suspension rig

Load case	Total Suspended Load (TSL)	Weight of outboard portion	Weight of inboard portion	Horizontal force (Fh)
Load case 1 Working load	$1,25 \times \text{TSL} + 1,25 \times \text{TSHL}$	$1,25 \times \text{Mo}$ (a)	$1,25 \times \text{Mi}$ (a)	$1,25 \times \text{Fw1 Plat} + 1,25 \times \text{Fw1 Rig} + 1,25 \times \text{Fw}_{\text{MH}} \text{ (b)} + 2 \times \text{M} \times \text{acc}$ (c)
Load case 2a	$1,5 \times \text{RL} + 1 \times \text{SWP} + 1,25 \times \text{HWLL} + 1 \times \text{HSW}$	$1 \times \text{Mo}$	$1 \times \text{Mi}$	0
Load case 2b – Out of service conditions	generally 0	$1 \times \text{Mo}$	$1 \times \text{Mi}$	$\text{Fw2 Plat} + 1 \times \text{Fw2 Rig}$
Load case 3 – Triggering of the secondary device	$\text{Sd} \times \text{TSL} + 1,1 \times \text{TSHL}$	$1 \times \text{Mo}$	$1 \times \text{Mi}$	0

Fw1 = In-service wind force
Fw_{MH} = In-service wind force on material (assumed minimum 5 m² and a minimum of 625 N)
Fw2 = Out-of-service storm wind force
HWLL = Working load limit of materials hoist
HSW = Mass of all suspended materials hoist items
TSHL = Total suspended hoist load (TSHL = HWLL + HSW)
Sd is actual value in accordance with test B.1.4 or B.1.5.
The most unfavourable combination of the forces shall be considered for the calculation.

- a) For static suspension rig use $1 \times \text{Mo}$ and $1 \times \text{Mi}$.
- b) Fw1 on platform: The minimum horizontal load on the suspension points of the ropes is $0,1 \times \text{TSL}$ in all directions.
- c) Acceleration forces for traversing suspension rig (trolley) are $2 \times \text{M} \times \text{acc}$.

M = mass of moving parts

acc = calculated acceleration of the drives

6.5.3.2 Structural calculations for TSP suspension rigs

The strength of a TSP suspension rig is to be proven for the load cases given in Table 10.

Table 10 — Load cases for TSP suspension rig

Load case	WLL of the hoist(s)	Weight of outboard portion	Weight of inboard portion	Horizontal force (Fh)
Load case 1 Working load	$1,25 \times WLL + 1,25 \times TSHL$	$1,25 \times Mo$ (a)	$1,25 \times Mi$ (a)	$1,25 \times Fw1 + 1,25 \times F_{WMH}$ (b)
Load case 2a	$1,5 \times WLL + 1,25 \times HWLL + 1 \times HSW$	$1 \times Mo$	$1 \times Mi$	0
Load case 3 Triggering of the secondary device	$2,5 \times WLL + 1,1 \times TSHL$	$1 \times Mo$	$1 \times Mi$	0
Out of service condition	generally 0	$1 \times Mo$	$1 \times Mi$	Fw2

WLL= Working Load Limit of platform winch
Fw1 = In-service wind force
F_{WMH} = In-service wind force on material (assumed minimum 5 m² and a minimum of 625N)
Fw2 = Out-of-service storm wind force
HWLL = Working load limit of materials hoist
HSW = Mass of all suspended hoist items
TSHL = Total suspended hoist load (TSHL = HWLL + HSW)
The most unfavourable combination of the forces shall be considered for the calculation.

- a) For static suspension rig use $1 \times Mo$ and $1 \times Mi$.
- b) Fw1 on platform: The minimum horizontal load on the suspension points of the ropes is $0,1 \times TSL$ in all directions.

The WLL of the hoist is considered as the maximum calculated force in the wire ropes.

All parts of a temporary suspension rig shall be capable of being reused and re-erected and should be designed so as to prevent failure from fatigue or wear in normal use, including additional stresses which can be induced in assembly, dismantling, transportation and storage.

6.5.4 Stability calculations for suspension rigs

6.5.4.1 Stability calculations for BMU suspension rigs

This section applies to rail and non-rail mounted BMU suspension rigs with either roof or platform-mounted hoists. The rails may contribute to the resistance to the overturning moment if the anchoring system and roof structure have been designed accordingly.

A BMU suspension rig is regarded as adequately stable if, referring to the most unfavourable fulcrum in each case, the stability moment is equal or greater than the overturning moment in each of the load cases specified as follows.

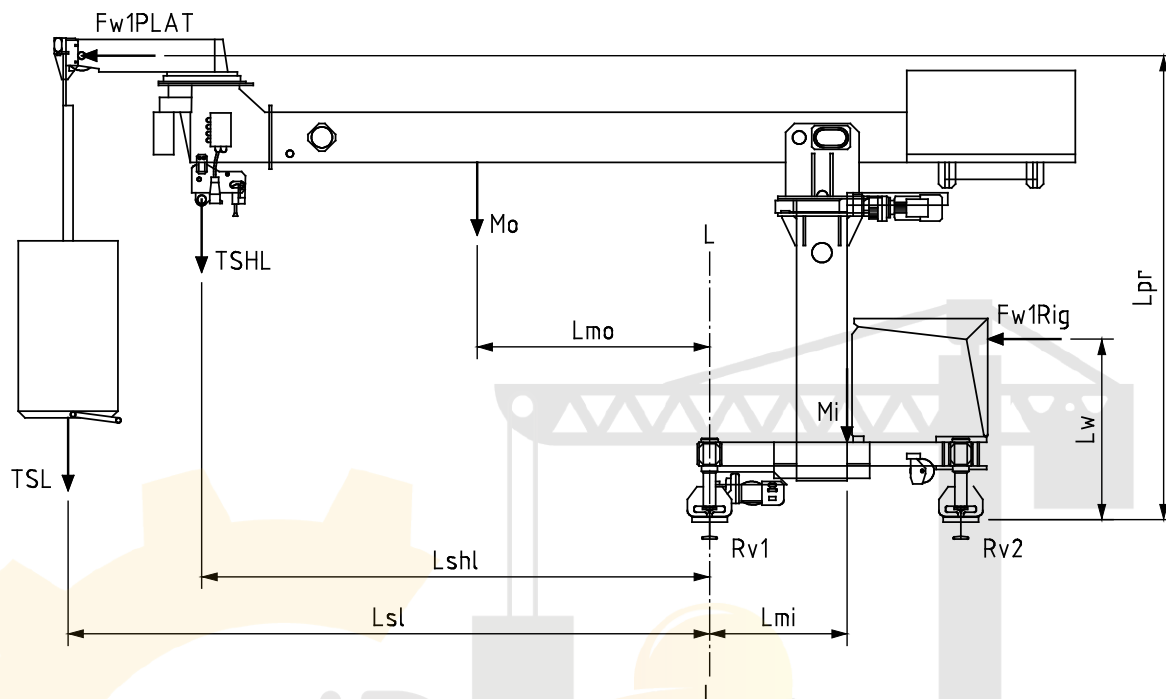

Figure 11 — Trolley unit stability calculation

The stability of a BMU suspension rig is to be proven by calculation using the coefficients given in Table 11.

$$TSL = RL + SWP + Mwr + Mc \quad (8)$$

BMU working position calculation:

$$\text{Prove that: } (2 \times TSL \times Lsl) + (1,25 \times Mo \times Lmo) + (1,25 \times Fw1 \text{ Rig} \times Lw) + (1,4 \times TSHL \times Lshl) + (1,25 \times Fw1 \text{ Plat} \times Lpr) < Mi \times Lmi \quad (9)$$

BMU parking position calculation:

$$\text{Prove that: } (Mo \times Lmo) + (Fw2 \text{ Rig} \times Lw) + (Fw2 \text{ Plat} \times Lpr) < Mi \times Lmi \quad (10)$$

All dimensions for calculations shall be the maximum for the particular system to ensure that the most unfavourable possible loading conditions are considered. The design reactions as a result of the above calculation shall be presented to the building structural engineer as detailed in Annex D.

Table 11 — Stability coefficients for BMU suspension rigs

	Total suspended load (N)	Weight of outboard portion (N)	Weight of inboard portion (N)	Horizontal force (Fh) (N)
Working stability	$2 \times \text{TSL} + 1,4 \times \text{TSHL}$	$1,25 \times \text{Mo}$	$1 \times \text{Mi}$	$1,25 \times \text{Fw1 Plat} + 1,25 \times \text{Fw1 Rig}$
Parking stability	generally 0	$1 \times \text{Mo}$	$1 \times \text{Mi}$	$\text{Fw2 Plat} + \text{Fw2 Rig}$

Fw1 = In-service wind force
 Fw_{MH} = In-service wind force on material (assumed minimum 5 m² and a minimum of 625 N)
 Fw2 = Out-of-service storm wind force
 HWLL = Working load limit of materials hoist
 HSW = Mass of all suspended materials hoist items
 TSHL = Total suspended hoist load (TSHL = HWLL + HSW)
 Sd is actual value in accordance with test B.1.4 or B.1.5.
 The most unfavourable combination of the forces shall be considered for the calculation.

6.5.4.2 Stability calculations for TSP suspension rigs

This section applies to rail and non-rail mounted TSP suspension rigs. The rails may contribute to the resistance to the overturning moment if the anchoring system and roof structure have been designed accordingly.

A TSP suspension rig is regarded as adequately stable if, referring to the most unfavourable fulcrum in each case, the stability moment is equal or greater than the overturning moment in each of the load cases specified below.

The stability of a TSP suspension rig is to be proven by calculation using the coefficients given in Table 12.

Table 12 — Stability coefficients for TSP suspension rigs

	Total suspended load (N)	Weight of outboard portion (N)	Weight of inboard portion (N)	Horizontal force (Fh) (N)
Working stability	$3 \times \text{WLL} + 1,4 \times \text{HWLL}$	$1,25 \times \text{Mo}$	$1 \times \text{Mi}$	Ignore
Parking stability	generally 0	$1 \times \text{Mo}$	$1 \times \text{Mi}$	$\text{Fw2 Plat} + \text{Fw2 Rig}$

WLL = Working load limit of platform winch
 Fw1 = In-service wind force
 Fw_{MH} = In-service wind force on material (assumed minimum 5 m² and a minimum of 625N)
 Fw2 = Out-of-service storm wind force
 HWLL = Working load limit of materials hoist
 HSW = Mass of all suspended hoist items
 TSHL = Total suspended hoist load (TSHL = HWLL + HSW)
 The most unfavourable combination of the forces shall be considered for the calculation.

6.5.5 Rail tracks and their support systems

The following items shall be checked against limiting values:

- a) resistance of rail track cross-sections against deflection/shearing/buckling;
- b) resistance of support members against deflection/buckling/crushing/crippling;
- c) wheel contact pressure.

Requirements on the design for rail tracks and their support systems are given in Annex G.

Provision should be made to ensure that a trolley unit cannot run off its rails, especially at turntables, spur-tracks shunts, run-offs or track ends, by means of mechanical stops.

In cases where it is necessary to provide roof anchorages the attention of the structural engineer should be drawn to the possibility of damage to the fabric of the building caused by their installation and maintenance. The maximum loads should be calculated and submitted to the structural engineer of the building for approval. Examples of how to present this information are given in Annex D.

All partially or totally hidden fixings associated with SAE should be designed for the lifetime of the building or structure using appropriate materials to ensure that enclosed components are not required to be exposed in the future to check for possible corrosion.

6.5.6 Requirements for other suspension rigs

6.5.6.1 Strength of davit mechanical anchors

This section applies to a davit that is fixed to a roof structure.

Where anchors are fixed to concrete the load on the anchors R_v shall be calculated as follows:

$$R_v \times L_s = C_{wr} \times WLL \times L_o + SWR \times L_b \quad (11)$$

where

C_{wr} is equal to or greater than 3.

R_v shall be less than the design value of the resistance of the anchor(s) (R_d).

آریا ایمن آوات

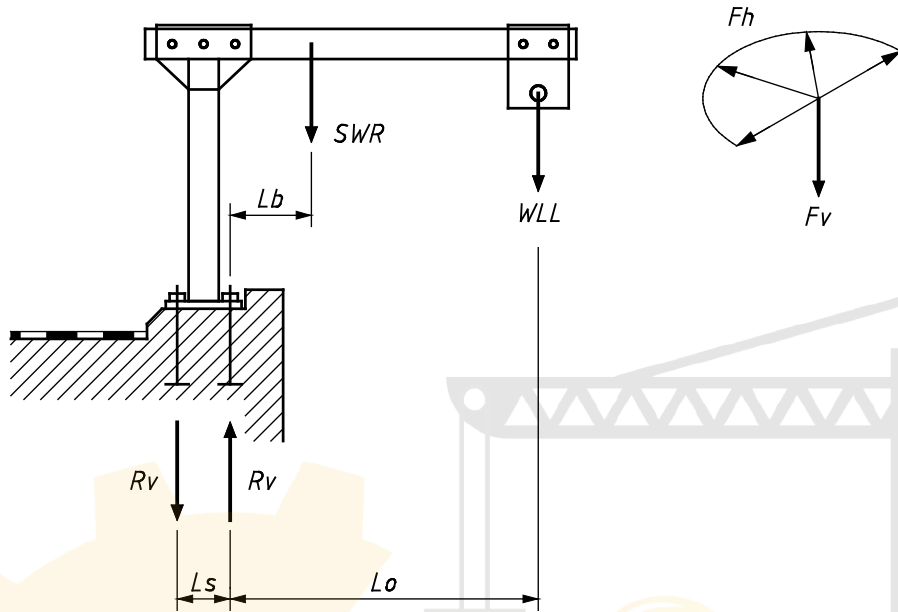

Figure 12 — Fixed Davit

6.5.6.2 Calculation for parapet clamp

A parapet clamp is regarded as having adequate strength if the clamp withstands the forces imposed in Formula 12 and Formula 13.

$$R_h \times L_s = C_{wr} \times WLL \times L_o + SWR \times L_b \quad (12)$$

$$R_v = C_{wr} \times WLL + SWR \quad (13)$$

where

C_{wr} is equal to or greater than 3.

Formula 12 and Formula 13 also set out the requirements to check that the strength of the parapet is adequate.

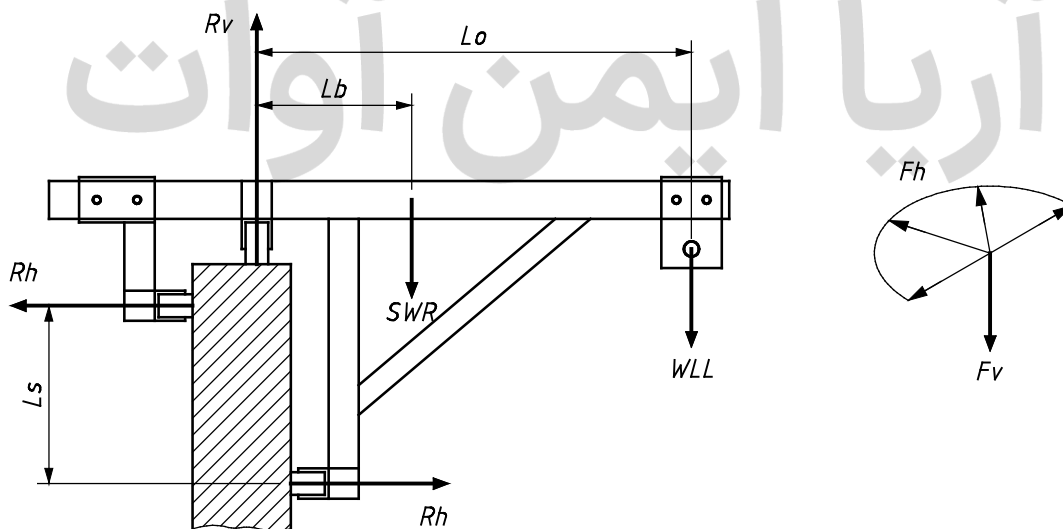

Figure 13 — Parapet clamp

6.5.6.3 Monorails

Monorails should be calculated in accordance with Table 13. Monorails for suspended platforms with more than one hoist should be calculated in such a way that only one hoist or suspension system is assumed to fail. This means that a load of $2,5 \times WLL$ is used for the first or only hoist and $1,25 \times WLL$ for any other hoist(s).

Table 13 — Load cases for monorails in conjunction with platform-mounted hoist(s)

Load case	WLL of the hoist(s)	Weight of the monorail + trolley	Horizontal force F_h
Load case 1 Normal working	$1,25 \times WLL$	$1 \times SWR$ for monorail $1,25 \times SWR$ for trolley	$0,1 \times WLL$
Load case 2 Occasional loads	$1,5 \times WLL$	$1 \times SWR$	0
Load case 3 Triggering of the fall arrest device	S_d or $2,5 \times WLL$ for 1 st hoist plus: $1,25 \times WLL$ for other hoist(s)	$1 \times SWR$	0

Where S_d is less than 2,5 the actual value for S_d may be used for a BMU installation.

When performing the calculations it should be considered that independently moving monorail trolleys might traverse next to each other unless a spreader bar or other arrangement is provided to ensure that the trolleys are kept apart.

NOTE For BMU platforms with platform-mounted hoists the WLL used here is the maximum lifting capacity of the hoists as determined by the platform manufacturer/supplier.

6.5.6.4 Monorail support anchors

All partially or totally hidden fixings associated with SAE should be designed for the lifetime of the building or structure using appropriate materials to ensure that enclosed components are not required to be exposed in the future to check for possible corrosion.

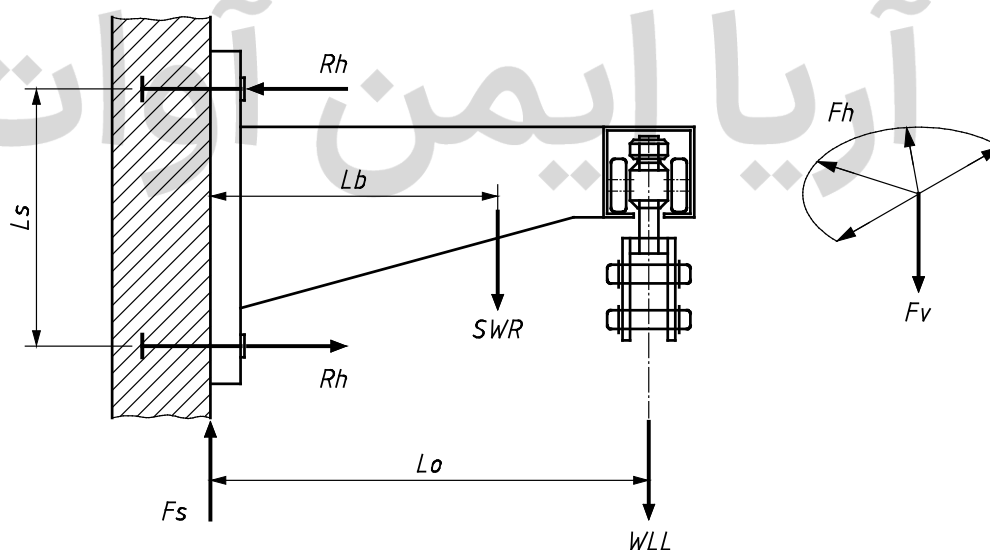

Figure 14 — Monorail

Where anchors are fixed to concrete the loads R_h and F_s on the anchors shall be calculated as follows:

$$R_h \times L_s = C_{wr} \times WLL \times L_o + SWR \times L_b \tag{14}$$

$$F_s = C_{wr} \times WLL + SWR \tag{15}$$

where

C_{wr} is equal to or greater than 3.

R_h shall be less than the design value of the resistance of the anchor(s) (R_d).

F_s shall be less than the design shear resistance of the anchor(s).

6.5.6.5 Stability calculation for counterweighted suspension beam

A suspension beam is regarded as stable if, when referring to the most unfavourable fulcrum, the stability moment is equal to or greater than three times the overturning moment when the WLL of the beam in its working configuration.

The stability is to be proven by calculation for the following case:

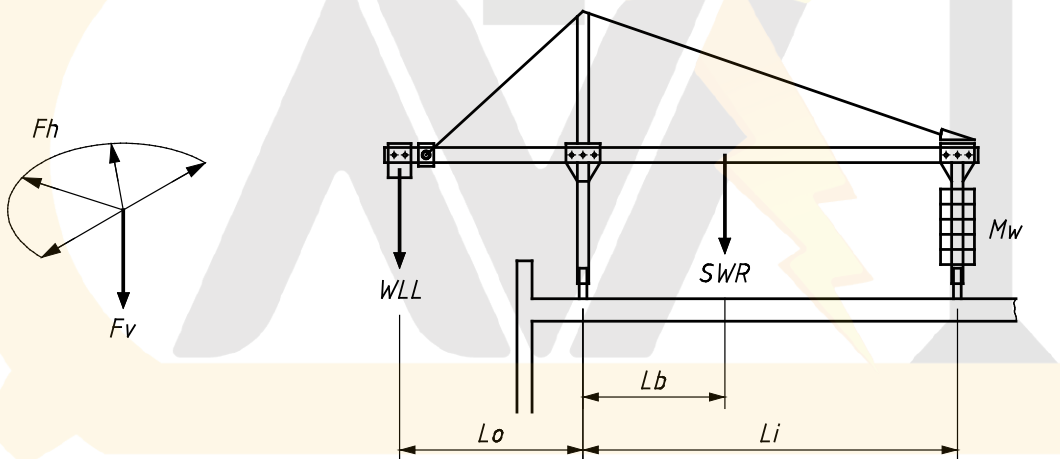

Figure 15 — Typical suspension beam

$$C_{wr} \times WLL \times L_o \leq M_w \times L_i + SWR \times L_b \tag{16}$$

where

C_{wr} is equal to or greater than 3.

The fulcrum is the line between the contact points of the front (outboard) supports.

6.5.6.6 Secondary wire rope anchor on rigid structures

When secondary wire rope anchor points are attached to a structure having a high rigidity (e.g. concrete or metal structures) the stresses within the anchor points, the SAE and the structure itself shall not exceed the yield limit of the materials when calculating the stresses imposed by a force equal to:

$$F_v = S_d \times WLL \tag{17}$$

S_d is the actual value in accordance with Test B.1.4.

If S_d is less than or equal to 3 then no additional requirements apply.

If S_d is higher than 3 but lower than 5 it is necessary to incorporate a shock absorber that limits $S_d \leq 3$.

If S_d is higher than 5 the system shall not be used.

6.6 Loadings on the building

6.6.1 Safety factors

The design calculations defined in this standard are carried out in accordance with the permissible stress method.

Structural engineers generally use the limit state method (Eurocodes EC1 and EC3) to design the building or parts of building directly affected by the SAE actions.

This paragraph gives information to clarify the relation between the loads defined in Tables 9, 10, 11 and 12 and the design values to be considered for the calculation of the building structure in accordance with Eurocodes.

General principles of safety using the limit state method (partial safety method, ref Eurocodes).

ACTIONS RESISTANCE

$$S_d = S_k \times \gamma_f \leq R_d = R_k / \gamma_m$$

S_d = Design value of the load (S_d from Eurocodes)

S_k = Characteristic loads (including the dynamic factors)

γ_f = Partial safety factor on the loads

R_d = Design value for resistance

R_k = Characteristic resistance

γ_m = Partial safety factor for resistance

S_k can be calculated using the Tables 9, 10, 11 and 12 for different appliances and load cases.

It is recommended that the following factors be applied by the structural engineer as a minimum to the load cases for the purpose of identifying the design loads for the superstructure (building). However it is the responsibility of the structural engineer to ensure imposed loads for the SAE are accounted for in the superstructure design.

Guidance on the presentation of loadings is given in Annex D.

6.6.2 Recommended values for partial safety factor (γ_f)

Load case 1 =	Variables actions in normal operating condition	1,6
Load case 2 =	Variables actions in occasional use	1,4
Load case 3 =	Accidental actions	1,1
Stability load =	Calculated values actions to satisfy the stability criteria	1,1

6.7 Calculation for steel wire rope

NOTE These requirements apply to all suspension and secondary steel wire ropes involved directly or indirectly in supporting a platform.

6.7.1 General

The calculated coefficient Z_p of a steel wire rope is as follows:

$$Z_p = \frac{F_o}{S} \quad (18)$$

where

Z_p is equal to or greater than 8 for a single active rope suspension system;

Z_p is equal to or greater than 12 per rope for a double active rope suspension system.

The self-weight of the rope shall be included in the calculations.

6.7.2 Calculation of the Force S in the suspension wire rope

6.7.2.1 Roof mounted hoist with double active rope suspension system

S is equal to the total self-weight of the platform plus the self-weight of the ropes and the RL permitted on the platform placed on the area S_a located in the most unfavourable position (see 6.3.4 for calculation of RL and S_a) divided by the number of steel wire ropes or falls on the most loaded suspension point. See load in position +) in Figure 7 and Figure 8.

6.7.2.2 Platform mounted hoist

S is equal to the WLL of the hoist divided by the number (N_r) of steel wire ropes used in that hoist carrying the suspended load. The self-weight of the ropes and any tension weights shall be included in the calculation.

$$S = \frac{WLL}{N_r} + M_{wr} \quad (19)$$

6.7.3 Rope terminations

Rope terminations that carry the full suspended load and their associated safety ropes shall be capable of supporting at least 80 % of the minimum breaking load of the rope.

For drum winches the strength of the attachment of each rope to the drums shall not be less than twice the total suspended load.

6.8 Calculation for restraint systems

The mullion guide and anchor restraint points shall be securely attached to the building and capable of withstanding the operational and wind loads imposed upon them with the platform in any position. The members linking the platform to the mullions or anchor restraint points shall also be capable of withstanding the operational and wind loads imposed upon them. For calculation purposes, the minimum design value of the force applied by the restraint system at a single point on vertical facades shall be 1 kN in any direction.

Loads imposed on sloping facades shall be calculated for each individual case using the rules applicable for rails and monorails (see 7.9).

7 Suspended platforms

7.1 Requirements for the platform

7.1.1 The dimensions shall be sufficient for the number of persons allowed on the platform together with their tools and materials. As a general rule, the minimum internal width of the platform ignoring any control boxes and panels should be not less than 500 mm. The working surface shall be at least 0,25 m² per person.

7.1.2 The decking of the platform shall have a sound, slip resistant surface (e.g. latticed or chequer plate). It shall be fixed so that it can only be removed by intention.

7.1.3 Any openings in the decking shall be dimensioned so as to prevent the passage of a sphere of 15 mm in diameter. Adequate provision shall be made for drainage.

7.1.4 Guardrails, intermediate rails and toe boards shall be fitted to the perimeter of the platform. The height to the top of the guardrail shall be not less than 1,0 m measured from the upper side of the rail to the surface of the platform decking. The clear vertical distance between the intermediate rails and either guardrails or toe boards shall not exceed 500 mm. Intermediate rails are not required if the platform is clad. For TSPs, toe boards shall be not less than 150 mm above the surface of the platform decking. Toe boards are not required if the platform is clad. There shall be no sharp edges or corners.

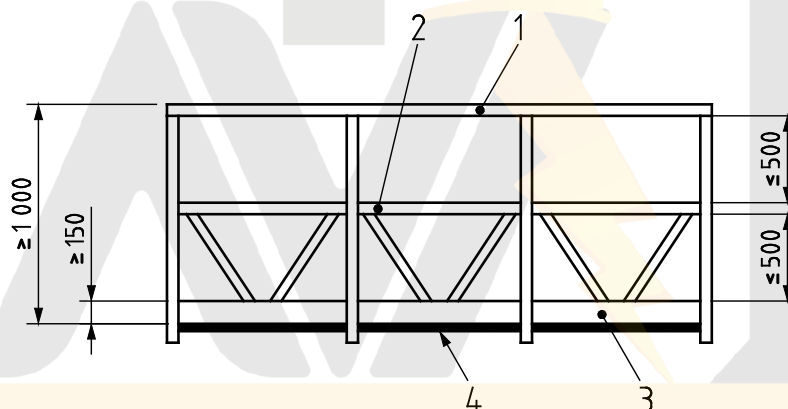

Key

- 1 guardrail
- 2 intermediate rail
- 3 toe board
- 4 platform decking

Figure 16 — Platform dimensions

7.1.5 Where there is a high risk of objects falling onto the platform and endangering persons then it shall be provided with a roof or other means of protection.

7.1.6 Where a specific Risk Assessment indicates that there is a need for PPE e.g. on a BMU, which has a roof mounted hoist system and the platform is being manually lowered, (in an emergency situation) the platform could rest on a ledge or obstruction and could become unbalanced and tilt.

A restraint/fall-arrest point, in accordance with EN 795, shall be provided on either the platform, or, on the suspension point. However, if the restraint/fall-arrest point cannot be attached as stated above then an anchor point for the restraint/fall-arrest system should be attached to the structure of the building.

Precise information on the platform restraint system and its use should be included in the manual and also in the notices on the platform itself.

7.1.7 Minimum height of stirrups:

The minimum height of the stirrup or pivot point on the stirrup shall be related to:

- the width of the platform;
- the self-weight of the platform;
- the gravity point location of the platform;
- the gravity points of the loads (1 050 mm above the decking for persons and on the decking for materials) and 150 mm inside the toe board.

The lateral inclination of the platform shall then be no more than 8 degrees.

7.1.8 Components shall not have sharp edges, angles or protruding parts that could cause injury.

7.2 Modular platforms

7.2.1 All components shall be designed to ensure that they cannot be incorrectly assembled. Fixing bolts and other devices shall be clearly visible without any dismantling.

7.2.2 Components that form joints shall be designed to withstand the stresses they will have to support during use and repeated assembly and disassembly so that once assembled they can only be dismantled by intention.

7.2.3 Small parts such as anchor pins and retaining clips shall be joined together by permanent linking connections.

7.3 BMU platforms

7.3.1 BMUs with platform-mounted hoists shall be provided with wire winders to store the suspension and safety ropes with guards that allow their operation to be visually monitored. Management of the power cable by means of a storage compartment or other means is to be considered.

7.3.2 All sides of BMU platforms shall be completely enclosed. If mesh sides are incorporated they shall be so designed to prevent the passage of a sphere of 15 mm diameter except for foot holes. Where appropriate, platforms shall be fitted with handles and foot holes that assist users when entering or leaving the platform.

7.4 Platform gates

7.4.1 Access gates shall slide or open inwards.

7.4.2 Access gates shall be constructed to return automatically to the closed and fastened position or shall be interlocked to prevent operation of the SAE until they are closed and fastened. The access gate shall only open by intentional intervention.

7.5 Multi-deck platforms

7.5.1 A multi-deck platform can be a TSP or BMU depending upon the location and nature of the task.

7.5.2 If two or more decks, one above the other, are used, a hatch shall be provided in the upper deck with a ladder allowing safe access between the decks. The hatch shall open upwards and not obstruct the ladder and shall not be able to remain in the open position.

7.5.3 The minimum clear height between two decks shall be 2 m.

7.5.4 Where the distance between the two decks is greater than 2,5 m protection hoops on the access ladder shall start at 2 m height measured from the surface of the lower platform base.

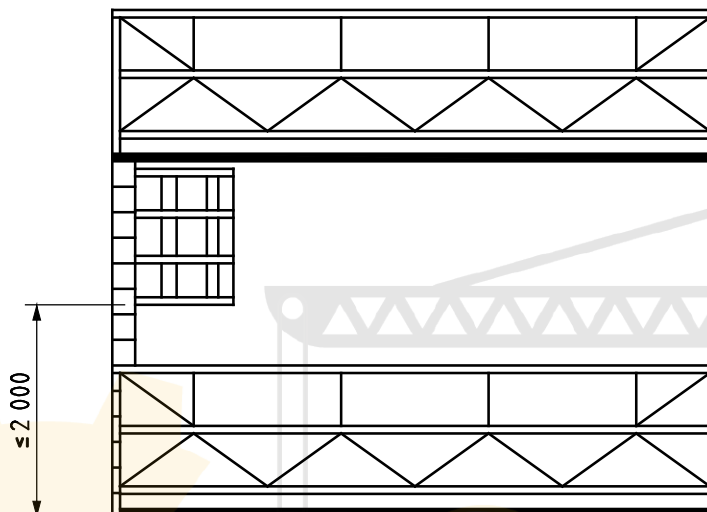

Figure 17 — Multi-deck platform

7.6 Suspended chairs

7.6.1 A suspended chair can be a TSP or BMU depending upon the location and nature of the task.

7.6.2 The seat of a chair shall not be less than 450 mm wide.

7.6.3 The back of the chair shall conform to Figure 4a) and shall be curved to fit the dorsal form.

7.6.4 A two-point restraint belt with a width of at least 40 mm shall be provided for the operator. Each anchor point of the two-point restraint belt shall have a minimum resistance to deformation of 1,2 kN.

7.6.5 All controls, including the emergency stop, shall be within easy reach of the operator.

7.7 Restraint systems

7.7.1 General

Where SAE is used in outdoor locations affected by wind and where the working height above ground level determines that a working rope length of greater than 40 m will be required then a platform restraint system is deemed to be necessary or limitations should be placed on its use.

When platform restraint systems are in use any movement of the suspension rig or trolley shall be coordinated with the restraint system so that all traversing, luffing, slewing and telescoping movements of the suspension rig are taken into account in the design and do not cause a hazard to occupants of the suspended platform.

Platform restraint can normally be provided by:

- a) mullion guides integrated into the facade;
- b) suspension wire rope restraints.

On buildings up to 60 m in height only, where no system of platform restraint is possible, then it is essential that strict limitations be placed on the wind speed in which the particular SAE may be used (see 7.7.4).

Special measures might be required for SAE working on inclined track systems. Depending upon the height and slope it might be possible to stabilize a suspended platform serving an inclined facade by means of friction and/or rolling devices (see 7.9).

The following information is for general guidance only and predicted local conditions should always be taken into account when determining whether or not to install a system of restraint for a suspended platform and which of the above systems is most appropriate.

These rules may not apply to the first and last lift when rigging a platform from the ground. In such cases, further restrictions on wind speed or other measures have to be implemented.

7.7.2 Mullion guide systems

7.7.2.1 Limit switches shall automatically stop the downward motion of a suspended platform to ensure that the restraint assemblies do not disengage from the mullion guides at the lowest level. If the lower ends of the guides are higher than ground level then provision shall be made to ensure that the platform and persons may be transferred to a position of safety should an emergency arise.

7.7.2.2 The mullion guides shall be designed so that the restraint assemblies may be easily attached or detached. Provision shall be made for operators to attach and detach these assemblies on the platform without the need for tools, at any position.

7.7.3 Suspension wire rope restraint systems

On BMU installations where a wire rope restraint system is employed the system shall be designed to conform to the following conditions:

- The lowest restraint level shall not be more than 40 m above natural ground level (see Figure 18a) and Figure 18b)).
- The distance between restraint levels above 40 m shall not exceed 20 m measured from the suspension points (see Figure 18c)).
- Where the design of the facade of the building incorporates features that have the effect of forming a stepped facade (e.g. the provision of a terrace etc.) the maximum height from the terrace level up to the first level of restraints shall not exceed 20 m (see Figure 18d)).
- When a platform is being lowered the operator(s) shall be reminded by means of visible and/or audible warnings to attach the restraint assemblies provided on the platform to the building at each restraint level. When a platform is being raised the platform shall automatically stop at each restraint level. The operator(s) shall then be required to carry out an action to acknowledge that the restraint assemblies have been detached from the building before being allowed to continue upwards.
- The restraint assemblies shall be attachable and detachable by an operator on the platform in a safe and simple manner. The assemblies shall be captive so that they cannot be dropped to the ground during attachment to or removal from their anchor points.
- The restraint assemblies shall be designed so as not to cause any damage to the suspension wire ropes when being fixed, removed or when in operation.
- Operatives should not be expected to reach more than 750 mm outside the perimeter of a suspended platform to attach and detach restraint assemblies on a building facade.

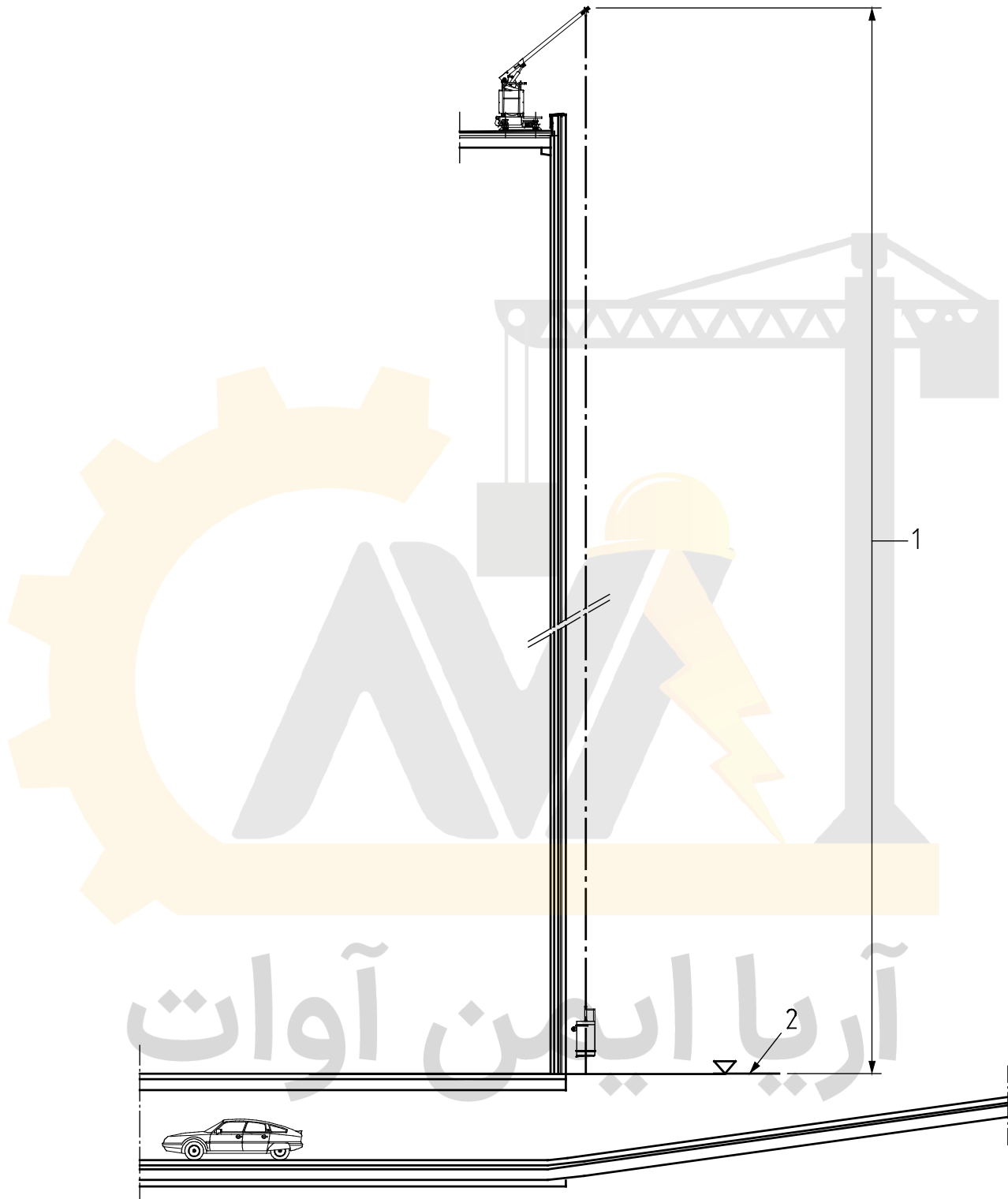

Key

- 1 working rope length (maximum 40 m)
- 2 natural ground level

a) BMU working without lateral restraints

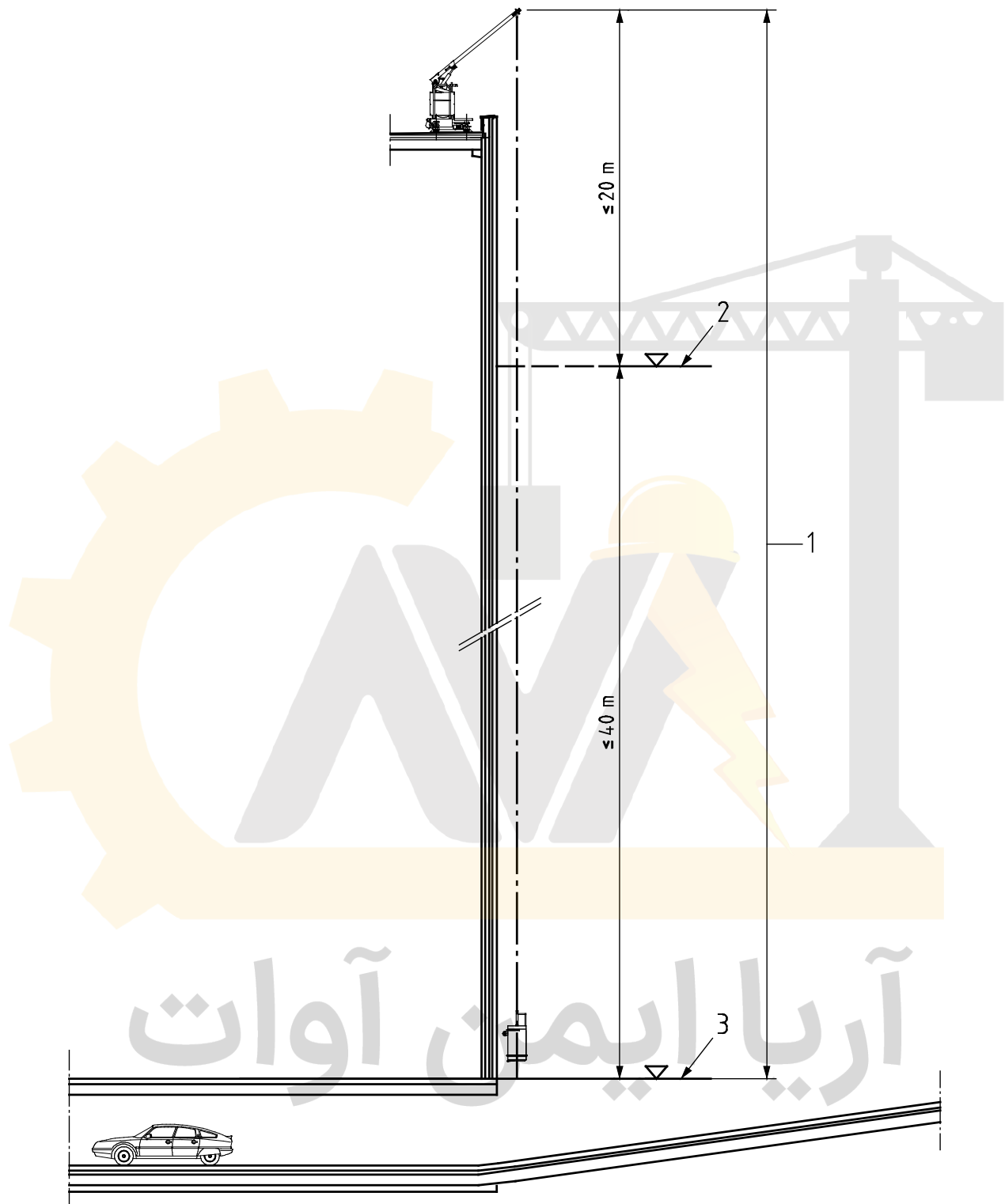

Key

- 1 working rope length (maximum 60 m)
- 2 restraint level
- 3 natural ground level

b) BMU with one level of restraints

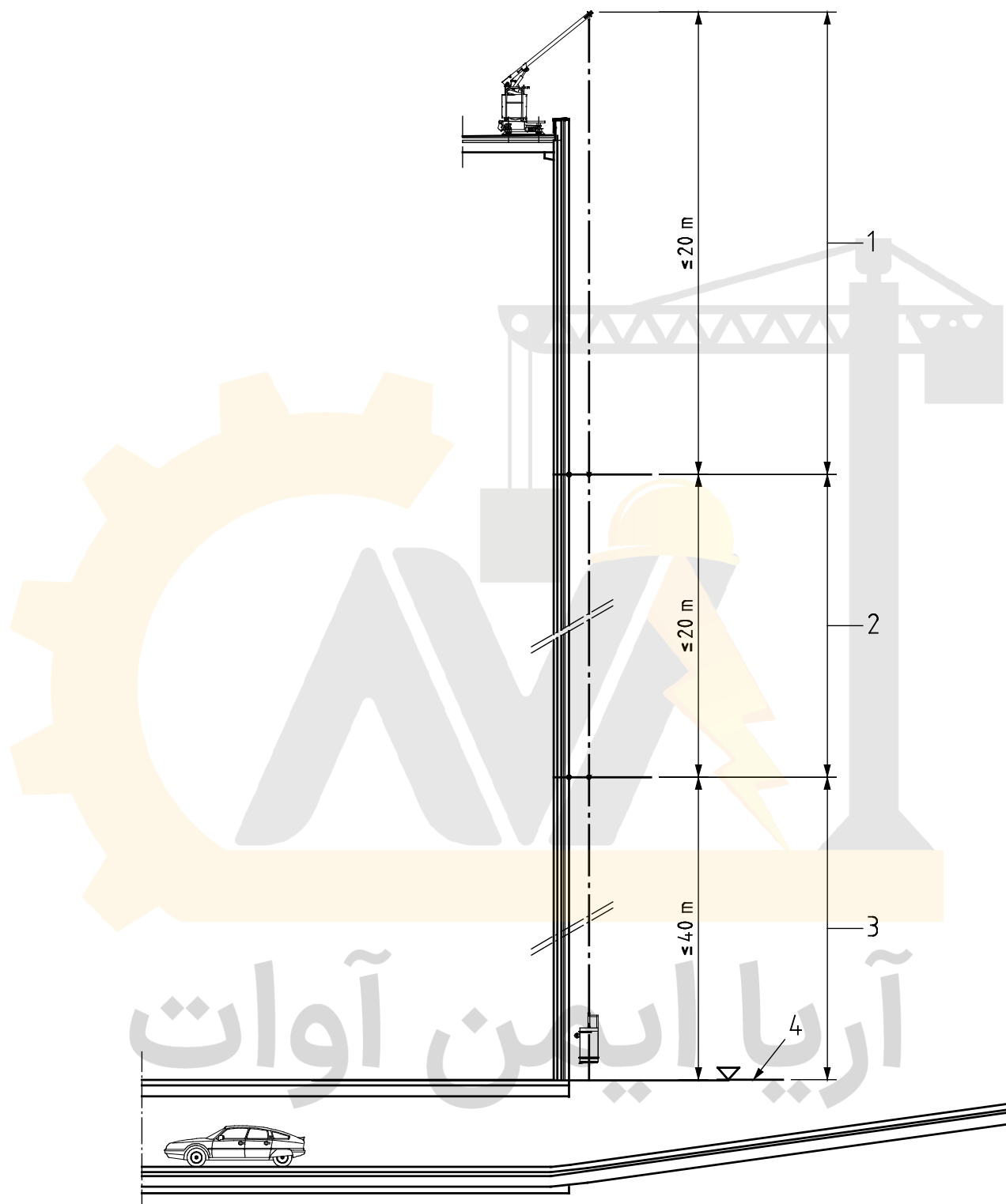

Key

- 1 distance between suspension point and highest restraint level (max. 20 m)
- 2 distance between restraint levels (max. 20 m)
- 3 distance between lowest restraint level and natural ground level (max. 40 m)
- 4 natural ground level

c) BMU working with more than one level of restraint

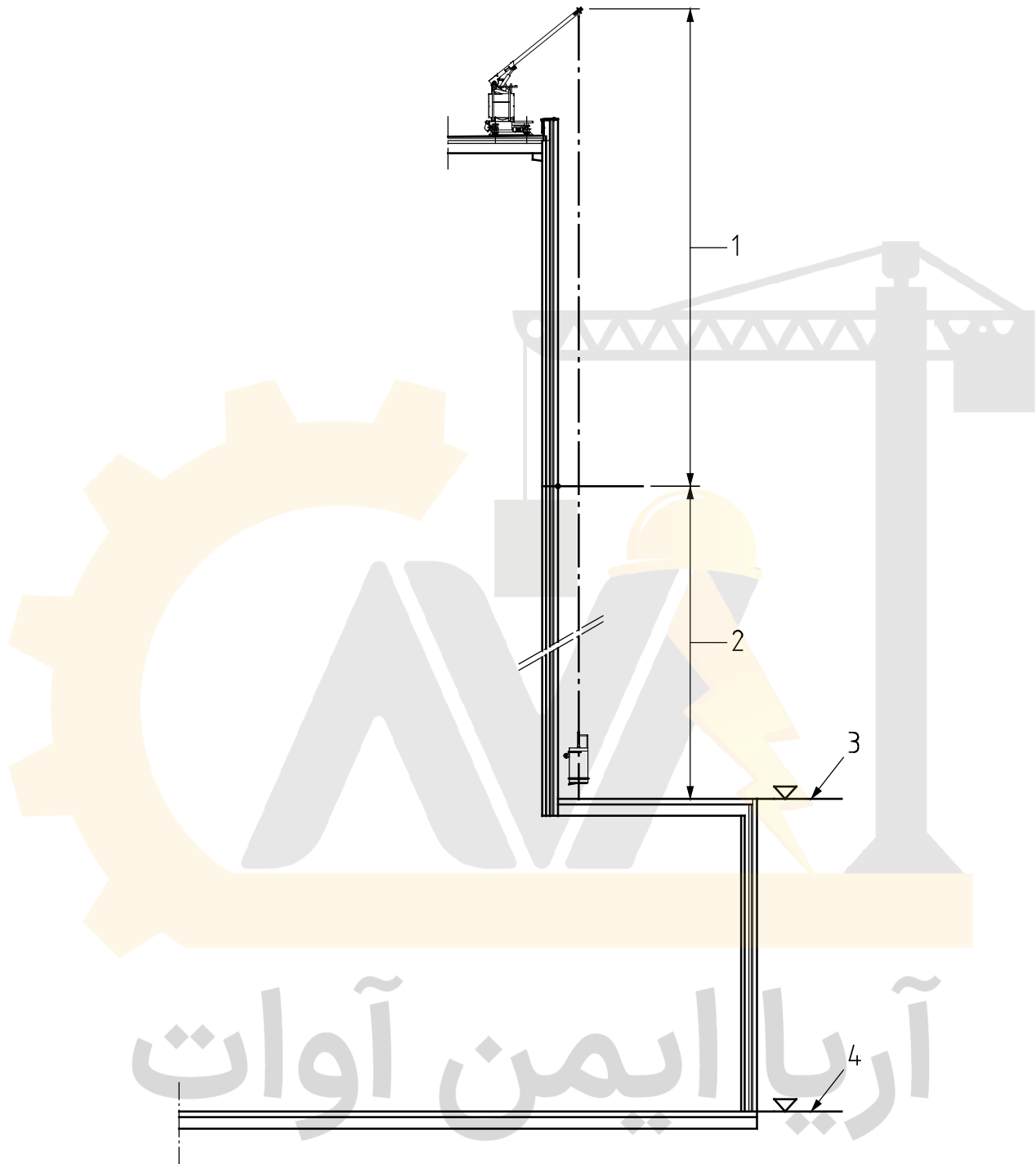

Key

- 1 distance between suspension point and highest restraint level (max. 20 m)
- 2 distance between lowest restraint level above the terrace (max. 20 m or 40 m above natural ground level)
- 3 terrace level
- 4 natural ground level

d) BMU working over lower terrace level

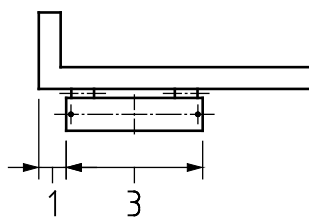

Situation without wind

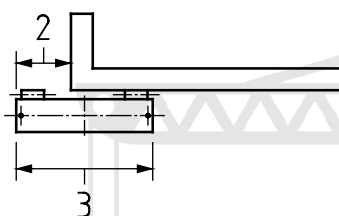

Situation including wind force on the platform

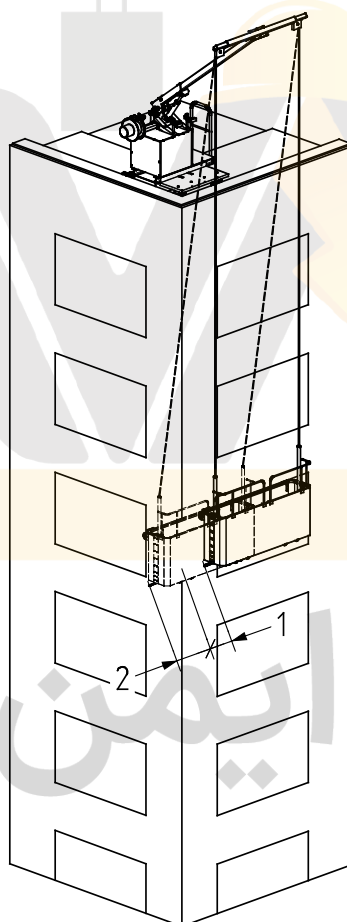

Key

- 1 500 mm maximum distance for reaching the corner of the facade
- 2 maximum 40 % of the length of the platform
- 3 length of the platform

e) Special case - Platform accessing corner of building

Figure 18 — Typical restraint systems

7.7.4 Placing strict limitations on permitted wind speed

On buildings up to 60 m in height operational limits on the use of a BMU system based on wind speed can be applied under certain circumstances where no platform restraint system is installed. This approach will inevitably reduce the time during which a BMU is available for use however.

In such cases the wind speed should be constantly measured and an audible warning activated in the platform if 95 % of the preset maximum working wind speed is reached. A maximum horizontal displacement of 4 m perpendicular to the facade and/or 40 % of the platform length parallel to the facade and a maximum restraining force of 200 N per operative is considered to be reasonable when calculating the maximum allowable operating wind speed for the particular lifting height (see Annex E).

Where BMUs are used in outdoor locations affected by wind, with the working height of over 60 m and the working rope length of over 20 m, a platform restraint system shall be used.

For TSPs with a lifting height over 40 m and installed on locations likely to experience wind speeds above 14 m/s a system of platform restraint shall be provided or other means to reduce the risks from this hazard shall be implemented.

7.7.5 Other restraint systems

Other systems of cradle restraint may be utilized provided the general parameters given above are maintained.

7.8 Wall rollers and buffers on the platform

Suspended platforms shall be provided with facade protection on their working face(s). This may take the form of buffer rollers or strips (see Figure 3 and Figure 4).

This protection has two functions:

- to minimize the risk of the platform from spinning and excessive swaying;
- to minimize the risk of damage to the facade of the building.

7.9 Platforms working on an incline

7.9.1 Additional requirements apply where suspension rigs for platforms suspended by wire ropes are working on an incline.

7.9.2 The platform shall be provided with rollers rolling on the incline. The number and location of rollers shall be appropriate to the maximum forces that the platform is capable of withstanding. The number and location of the rollers shall be such that the platform remains stable in use.

7.9.3 By design the platform deck shall remain horizontal within a tolerance of ± 8 degrees in both the longitudinal and lateral planes when the platform is rolling on an incline.

7.9.4 The hoisting system and associated wire rope winder(s) shall be designed to avoid any slack in the suspension rope or secondary rope. If a slack rope situation occurs lowering shall be automatically stopped.

7.9.5 If, at the end of the incline, the facade continues downwards vertically a limit switch shall detect the end of the incline and further lowering prevented.

7.9.6 The SAE shall be provided with a means for safe egress of personnel in the event of loss of power to the equipment.

7.9.7 Calculations for the stability of the suspension rig shall take into account the value and direction of forces imposed by the platform while working on an inclined facade.

8 Hoisting systems

8.1 General

8.1.1 Hoisting system

A hoisting system for SAE generally incorporates hoist(s), wire ropes, pulleys and guides and associated drive systems and safety related parts.

The SAE shall be fitted with a means of recording the amount of use the hoisting system has had.

8.1.2 Pulleys

Minimum pitch diameter of pulleys, drums and traction sheaves is given by the following formula:

$$D \geq H \times d \quad (20)$$

where

$H \geq 20$ for power operated hoists;

$H \geq 18$ for manually operated hoists.

For unloaded pulleys or when the deflection angle is less than 5° the minimum pitch ratio H may be reduced to 10.

The operating speed of a rope shall not exceed 0,3 m/s.

8.1.3 Mechanical transmission

The mechanical transmission between motor, brake, gearbox, drum and/or traction system shall be of the positive type and shall not depend upon frictional forces for its operation.

8.1.4 Moving parts

All moving parts of a hoist shall be guarded. For guidance, refer to EN ISO 13849-1.

8.1.5 Wire rope guides

The hoisting system shall be designed so that the wire ropes are guided through the hoist(s), secondary device(s) and pulley(s) to prevent the wire ropes leaving their intended route.

8.1.6 Service brakes

8.1.6.1 A hoist shall be provided with a service brake which operates automatically in the event of:

- interruption of the manual force applied to the crank or lever;
- loss of the mains power supply;
- loss of the power supply to the control circuit.

8.1.6.2 An irreversible gearbox is not regarded as a brake.

8.1.6.3 The service brake shall be capable of stopping the platform travelling at rated speed and with 1,25 times the WLL within a distance of 10 cm.

8.1.6.4 The material used for brake linings shall not be flammable.

8.1.6.5 A cover against ingress of lubricants, water, dust or other contaminants shall protect brake blocks and linings.

8.2 Manually operated hoists

8.2.1 General

8.2.1.1 A manually operated hoist shall be designed to require a positive crank or lever force to lift or lower the load.

8.2.1.2 A manually operated hoist shall be provided with a means to prevent uncontrolled movement or descent. Uncontrolled movement is understood to be a movement of more than a quarter of a turn of a crank or more than 10° angle of a lever.

8.2.2 Crank operated hoists

8.2.2.1 The mechanical advantage offered by the gear reduction system and manual crank shall not permit lifting of a load in excess of 2,5 times the WLL when a force of 625 N is applied to the end of a crank.

8.2.2.2 The maximum force applied to the end of a crank for lifting the WLL of the hoist shall not exceed 250 N.

8.2.3 Lever operated hoists

8.2.3.1 The mechanical advantage offered by the gear reduction system and lever shall not permit lifting of a load in excess of 2,5 times the WLL when a force of 1 kN is applied to the end of the lever.

8.2.3.2 The maximum force applied to the end of a lever for lifting the WLL of the hoist shall not exceed 400 N.

8.3 Power operated hoists

8.3.1 Prime mover

8.3.1.1 A power-operated hoist shall be designed to be power operated when lifting and when lowering.

8.3.1.2 A hoist shall be able to lift and lower a load at least equal to 125 % of its WLL. If a hoist can lift a load of more than 250 % of its WLL without stalling then an additional safety device (additional to the overload device) such as a current overload device, thermal overload device or torque limiting device shall be incorporated.

8.3.2 Electro-mechanical service brakes

NOTE In addition to 8.1.6, the following requirements apply:

8.3.2.1 In service conditions a continuous flow of current shall hold off the brake. An independent electrical device shall effect interruption of this current. If DC current feeds the brake coils an independent electrical contact shall be installed to interrupt the DC supply.

8.3.2.2 When the electric motor of the hoist is likely to function as a generator the electric device operating the brake shall not be fed by the driving motor. Braking shall become effective within 0,3 s after opening of the brake release circuit.

8.3.2.3 The action of the brake shall be applied by compression springs. These springs shall be supported and shall not be stressed in excess of 80 % of the torsional elastic limit of the material. Band brakes are not permitted.

8.3.3 Pneumatic and hydraulic mechanical service brakes

NOTE In addition to 8.1.6 and 8.3.2.3, the following requirements apply.

8.3.3.1 In service conditions, a continuous fluid pressure shall be required to hold off the brake.

8.3.3.2 Brakes shall be designed in such a way that unintentional lowering of a platform is prevented. The brake shall not reach the open position until the motor provides sufficient torque to hold the platform.

8.3.4 No-power descent

8.3.4.1 All hoists shall have a manually operated system that allows controlled descent of the platform within a reasonable period of time in case of power failure. This system shall be readily accessible to operator(s) on the roof or on the platform.

8.3.4.2 The manual descent shall have a "hold-to-run" action giving a minimum of 20 % of the normal running speed of the hoist under load.

8.3.4.3 In order to control the speed a centrifugal governor may be used during no-power descent. The controlled descent speed shall be lower than the triggering speed of the secondary device. In such cases, it shall be possible to test the secondary device.

8.3.4.4 The no-power descent of a roof mounted hoisting mechanism with two independent drives shall be designed to ensure that any longitudinal inclination of the platform is limited to 14°.

8.3.4.5 The no-power descent system shall be designed to prevent any part of the body being trapped or struck (e.g. solid hand wheel, electrical interlock, power cut-off if manual crank in use).

8.3.4.6 The secondary device shall be effective at all times during no-power descent.

8.3.5 Overload detection devices

8.3.5.1 All SAE shall be provided with an overload detection device to avoid danger to persons and damage to machines as a result of overloading. This device shall detect the loads due to persons, equipment and materials on the platform.

8.3.5.2 An overload device shall be fitted for each hoist.

8.3.5.3 For in-service conditions an overload shall be detected when the platform is lifted, lowered or stationary.

8.3.5.4 For BMUs the overload device(s) shall be triggered at or before reaching a load of 1,25 times the RL of the platform.

8.3.5.5 For TSPs the overload device(s) shall be triggered at or before reaching a load of 1,25 times the WLL of the hoist(s) or 1,25 times the reduced WLL in the case of de-rated hoist(s).

8.3.5.6 The overload device(s), once triggered, shall continuously isolate all movements except lowering until the overload has been removed.

8.3.5.7 An overload indicator shall continuously, either visually or audibly, warn the operator(s) on the platform when the overload device has been activated.

8.3.5.8 The setting elements for the pre-set limit of overload devices shall be protected against unauthorized adjustment.

8.3.5.9 Overload devices shall be designed to operate in such a way that the static and dynamic tests required by this standard can be carried out.

8.3.5.10 The overload device shall operate in the load range of up to 1,6 times the WLL of the hoist. The overload device shall be capable of withstanding a static load of three times the WLL of the hoist without permanent damage.

8.3.6 No load devices

SAE with roof-mounted hoists shall be provided with a device that stops the lowering of the platform as soon as a no-load situation occurs.

8.3.7 End of rope switch for roof mounted hoists

End of rope limit switches shall stop the platform when the minimum length of rope (specified in 8.4.4 and 8.6.2 c)) is reached at the hoist mechanism.

8.3.8 Maintaining the longitudinal level of a platform (anti-tilt device)

8.3.8.1 General

Hoisting mechanisms with two or more independent hoists shall be equipped with an automatic device to limit the longitudinal inclination of the platform to 14° from the horizontal. These devices may be either electrical or mechanical.

8.3.8.2 Electrical anti-tilt device

When triggered, the electrical anti-tilt device shall:

- on lifting, stop the upper hoist motor;
- on lowering, stop the lower hoist motor.

8.3.8.3 Mechanical anti-tilt device

For SAE with platform mounted hoists a solution could be to provide fall arrest devices that automatically limit the incline of the platform to 14°. These devices are self-sufficient and do not require an electrical output signal to be incorporated into the safety related part of the control system.

8.3.9 Obstacle detection

SAE shall be provided with device(s) that stop the lowering of the platform when an obstruction is encountered. This is achieved by:

- a) For BMUs, an obstacle device or devices (see Figure 3b) and Figure 4b)) shall be used.
- b) For TSPs, a device which engages automatically in case of a no-load condition and/or in the case of an inclination of the platform of more than 14° from the horizontal and which is self-sustaining (e.g. not requiring an electrical signal in the safety related parts of the control system) shall be used.

An overhead anti-collision detector or other device is also required where there is a potential hazard from an overhanging structure.

8.3.10 Lifting and lowering limit switches

8.3.10.1 Lifting limit switches shall be provided and positioned so that they automatically stop the platform at the highest level. Upward movement shall stop before contact with the ultimate lifting limit switches. Lifting limit switches may be used in the control system of the SAE to prevent or to allow suspension rig slewing, traversing, luffing, jib telescoping or slewing.

8.3.10.2 Lowering limit switches shall be provided and positioned so that they automatically stop the platform at the lowest level. If the lowest level is ground level, or a safe surface, an anti-collision device is regarded as a lowering limit switch. At the lowest level initiation of stopping shall occur before contact with the end-of-rope switches (see 8.3.7).

8.3.10.3 Ultimate lifting limit switches shall be provided and positioned so that the platform will come to a complete stop before reaching the extreme top of the suspension rope. After triggering of any one of these ultimate limit switches no lifting or lowering shall be possible until a competent person has taken corrective action.

8.3.10.4 Separate and independent control devices shall be used for the lifting limit and ultimate lifting limit switches.

8.3.10.5 For TSPs suspended from a stationary suspension rig ultimate lifting limit switches shall be provided. For TSPs rigged from ground level, lowering limit switches are not required.

8.4 Drum hoists

8.4.1 Safeguard against running off

8.4.1.1 The drums and their ancillary equipment shall be designed to ensure that the wire ropes cannot run sideways off a drum in the case of a slack wire rope situation.

8.4.1.2 Wire ropes shall be evenly layered on the drum (e.g. by using layering devices).

8.4.1.3 Angle of fleet

The maximum angle of fleet as shown in Figure 19 shall not exceed 2° or else shall be calculated in accordance with the hoist geometry.

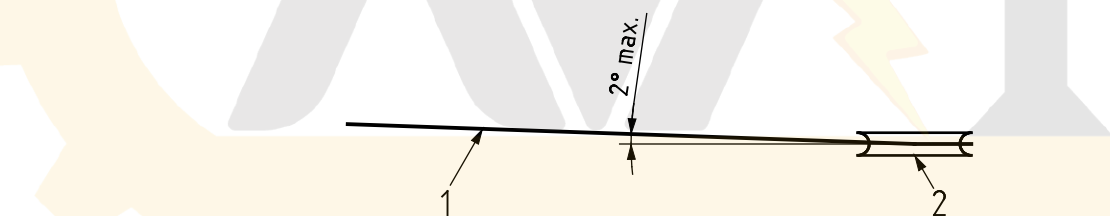

Key

- 1 wire rope
- 2 pulley

Figure 19 — Angle of fleet

8.4.2 Drum grooving

Wire rope drums shall be grooved, either machined or with a maximum standard of smoothness of $R_a = 12,5 \mu\text{m}$.

8.4.3 Hoist Drum

A device shall be provided to stop the hoist if a wire rope coils up unevenly.

The wire rope storage drum(s) shall be provided with flanged discs. The projection length of the flanges above the outermost wire rope layer shall be a minimum of 1,5 times the wire rope diameter.

8.4.4 End of downward movement

For a powered hoist, when the platform is at its lowest position, the downward movement shall be stopped automatically. At this position there shall be a minimum of two complete turns of rope remaining on the drum before the attachment point of the rope anchor system to the drum.

8.5 Traction hoists

8.5.1 Traction force

The hoist shall be designed to prevent any slipping or creeping of the wire rope in the traction system during lifting and lowering a load of not less than 1,5 times the WLL (see also 8.9).

A traction hoist shall not use tail-line tensioning to develop the necessary traction to lift and lower the load.

8.5.2 Traction sheave grooving

Traction sheaves shall have grooves that have a standard of smoothness of $R_a \leq 6,3 \mu\text{m}$. The traction sheave of a hoist shall be designed to suit the type and diameter of the wire rope intended for use with the hoist.

8.6 Powered wire winders

8.6.1 Safeguard against running off

8.6.1.1 The maximum angle of fleet shall be selected to ensure safe reeling of the wire ropes. If no additional guiding system is installed the angle of fleet shall not exceed 5° .

8.6.1.2 The winder shall be provided with flanged discs for this purpose. The projection length of the flanges above the outermost wire rope layer shall be at least equal to 1,5 times the wire rope diameter.

8.6.2 Roof mounted traction hoist

In the case of a roof mounted traction hoist the following additional requirements shall be met.

- a) Wire winders shall be used for the suspension and safety ropes.
- b) The hoist(s) shall stop automatically if the associated wire winder is not operating correctly (e.g. slack wire rope condition, the wire rope coiling up on one side of the winder).
- c) An end-of-wire rope switch shall be provided to ensure that the wire rope cannot be conveyed completely through the traction sheave and the hoist become de-reeved when a platform is in service.

8.7 Twin capstan drum hoists

8.7.1 A twin capstan drum hoist shall be designed to suit the type and diameter of the wire rope intended for use with the hoist.

8.7.2 A twin capstan drum hoist shall be designed to ensure that tail line tensioning is maintained in all circumstances (e.g. positive transmission between capstan hoist and winder).

The wire rope storage drum(s) shall be provided with flanged discs. The projection length of the flanges above the outermost wire rope layer shall be a minimum of 1,5 times the wire rope diameter.

8.8 Jaw operated traction hoists

8.8.1 A jaw operated traction hoist shall be designed in such a way that one set of jaws is gripping the suspension rope at all times, including when travelling in either direction.

8.8.2 The hoist shall be fitted with a mechanism to release the jaws to allow the rope to be fed into the hoist. A lever, independent of both the forward and reverse operating lever(s), shall operate the rope release mechanism. An interlocking device shall be provided to prevent unintentional release in case the mechanism can be released under load.

8.8.3 For a manual jaw operated traction hoist the machine shall be fitted with a device that limits the effort applied to the lever. The platform shall be prevented from lifting if this device is activated. The setting of this device shall be not more than two times the WLL of the hoist. Lowering of the platform shall still be possible.

8.8.4 For a powered jaw operated traction hoist with a lifting speed of less than 1 m/min the number of hoist operation cycles required for the wire rope test shall be the same as for manual jaw operated traction hoist.

8.9 Secondary devices

8.9.1 General

Rope suspension systems and secondary devices shall be installed to provide a coherent system to overcome the hazard of a platform falling. This requirement shall be met by one of the following.

- a) A single active rope suspension system installed in conjunction with the fall arrest device which is able to hold the platform in case of failure of the suspension wire rope or the hoist.
- b) In case of failure of one wire rope of a double active rope suspension system, the remaining wire rope shall be capable of holding the platform. In case of failure of the hoist, the secondary brake shall be capable of stopping and holding the platform.

8.9.2 Fall arrest devices

8.9.2.1 An overspeed fall arrest device shall automatically engage in the event of a failure of the suspension wire rope, overspeed on lowering the platform (more than 0,5 m/s), or the inclination of the platform exceeding 14°.

8.9.2.2 A fall arrest device shall be designed to limit the dynamic load coefficient S_d to a value that is as low as possible. The values in B.1.4 shall be considered the maximum.

8.9.2.3 A fall arrest device shall not be designed to stop the platform during normal in-service conditions.

8.9.2.4 A fall arrest device shall be engaged mechanically.

8.9.2.5 A fall arrest device shall be capable of being tested and reset. A fall arrest device shall be immediately operational after resetting and shall not be sacrificial.

8.9.2.6 The fall arrest device shall be designed so it cannot be manually released under load. However, when activated, a fall arrest device shall permit the platform to be lifted by the hoist.

8.9.3 Secondary brakes

8.9.3.1 Subclauses 8.1.6.4, 8.1.6.5 and 8.3.2.3 (if spring loaded secondary brake) refer to the service brake but are also applicable to the secondary brake.

8.9.3.2 A secondary brake shall automatically engage in the event of overspeed (more than 0,5 m/s) on lowering the platform.

8.9.3.3 A secondary brake shall be designed to limit the dynamic load coefficient S_d to as low a value as possible. The values in B.1.5 shall be considered the maximum.

8.9.3.4 A secondary brake shall only be used to arrest and sustain the platform during overspeed conditions.

8.9.3.5 A secondary brake shall engage mechanically.

8.9.3.6 For a powered hoist the secondary brake shall be fitted with a limit switch that interrupts the main power supply.

8.9.3.7 The secondary brake shall be capable of being tested and reset. The secondary brake shall be designed so that it cannot be released under load. The secondary brake shall be immediately operational after resetting and shall not be sacrificial.

8.9.3.8 The preset activating speed of a secondary brake shall be safeguarded against unauthorized resetting (e.g. by lead sealing).

8.9.3.9 The maximum inclination of the platform deck shall be not more than 14°, after the platform has stopped, due to the activation of the secondary device.

8.10 Rope pulleys

8.10.1 Ropes shall be prevented from leaving the grooves.

8.10.2 The distance between the edge of the pulleys and the protective components shall be not more than 0,3 times the rope diameter.

8.10.3 Rope grooves on pulleys shall have groove radius of between 0,52 to 0,65 times the nominal rope diameter.

8.10.4 The opening angle of the rope pulleys shall be symmetrical and between 30° and 55°.

8.10.5 The depth of the grooves shall not be less than 1,4 times the rope diameter.

8.10.6 Rope run-on points on pulleys shall be made safe to prevent hands and fingers being trapped and shall be provided with covers.

8.10.7 The pulley groove shall have a smoothness of $Ra \leq 6,3 \mu\text{m}$.

8.10.8 The maximum angle of fleet shall not exceed 4° from the centre line or shall be calculated in accordance with the geometry of the system.

8.11 Wire ropes

8.11.1 General

The platform shall be suspended by steel wire ropes that shall be galvanized or offer a similar corrosion resistance.

8.11.2 Wire rope diameter

The minimum wire rope diameter shall be 6 mm. The secondary wire rope shall have the same or a greater diameter as the suspension wire rope.

8.11.3 Wire rope terminations

Wire rope terminations shall be formed by means of metal filled sockets, self-tightening wedge type sockets, hand spliced eyes, ferrule secured eyes or any other system with equivalent safety. U-bolt grips shall not be used as a termination where their failure would affect safety.

8.11.4 Inspection facilities

Suitably positioned inspection hatches shall be provided to enable visual examination of steel wire ropes and rope terminations without removal of the ropes or major dismantling of the structural components of the SAE.

8.12 Auxiliary materials hoists

Most SAE installations are used with suspended platforms only. For reasons of safety and ergonomics, it is not recommended that items in excess of 25 kg in weight be handled by persons when working from a suspended platform.

SAE may also be used in conjunction with an auxiliary materials hoist.

On BMU installations where an auxiliary materials hoist is integrated for the purpose of carrying out future maintenance of the facade or other purposes the design of the suspension rig and its associated rail system shall take into account the size and weight of all potential additional loads and their effects on the strength and stability of the complete system.

When designing SAE to be used in conjunction with an auxiliary materials hoist the following additional hazards should be considered:

- unexpected movements of the platform and the load on the materials hoist by wind forces introducing possible impact, shearing, cutting and crushing hazards;
- dropping the load on to the platform or on to persons on the ground.

The following requirements are necessary for all SAE.

- Maximum materials hoist working load to be limited to 1 000 kg.
- The materials hoist hook shall be clearly marked with the working load of the materials hoist and a sign prohibiting the lifting of persons with the materials hoist. The platform shall also be marked with the working load of the materials hoist.
- Interested parties should determine the maximum imposed loads (including any uplift) on the structure of the building (see Introduction).
- An overload device shall be installed on the materials hoist set to operate at no more than 125 % of the working load of the hoist. The overload device, once triggered, shall isolate all movements except lowering of the platform and/or hoist until the overload has been removed.
- Maximum permitted wind speed for use of the materials hoist to be determined on the basis of 200 N restraining force per person on the platform.
- Stability and strength calculations of the machine, including the materials hoist, to be performed in accordance with Table 9 or Table 10 and Table 11 or Table 12.
- When an emergency stop is activated the materials hoist and platform shall stop.
- The materials hoist system shall have a facility that enables controlled descent of the suspended load or for it to be moved to a place of safety in case of power failure. This system shall be accessible at all times when the SAE is in use.

The following additional requirements are necessary for BMUs with roof-mounted hoists.

- An electric control device to minimum category 1 in accordance with EN ISO 13849-2:2012 shall be installed to prevent the bottom of the load rising above the guardrail of the platform. When this device is

activated the only movement permitted is to correct the relative positions of the platform or materials hoist.

- The maximum speed of the materials hoist shall be the same as the platform (i.e. max 0,3 m/s). When used together the speed of the hoist and platform shall be approximately the same to automatically limit their relative level to +/-1 m.

The following additional requirements are necessary for BMUs with platform-mounted hoists and all TSPs:

- Where a materials hoist is suspended from a separate suspension rig and the additional load is to the side or just above the platform guardrail a guiding system may be used to restrain the load so it cannot fall into the platform instead of the electric control device described above.

Refer to EN 14492-1:2006+A1:2009.

9 Suspension rigs

9.1 General

Where suspension rigs are used in conjunction with a demountable platform a safe means of rigging and de-rigging the suspended platform is required.

NOTE See also Introduction.

9.2 Drive Systems

9.2.1 General

Drive systems cover all parts of the installation (i.e. lifting, lowering, slewing, traversing, luffing, telescoping). Hoisting equipment including wire ropes, pulleys and wire rope winders are covered in Clause 8 as well as in this clause.

9.2.2 Travel limits of drive systems

9.2.2.1 Mechanical end stops shall be provided and positioned so that they stop the movement of a suspension rig or trolley before reaching any dangerous position and without causing any permanent damage to the suspension rig or track system. End stops shall be through bolted or welded and not rely on friction.

9.2.2.2 Travel limit switches shall be provided and positioned so that they automatically stop powered movement at the end of travel. Movement shall normally be stopped before contact with the end stops is made.

9.2.3 Brakes and secondary devices

Lifting and lowering drive systems, suspension rigs, and traversing trolleys running on an incline and which can move under the action of gravity alone, shall be provided with a service brake and secondary device to stop any uncontrolled movement.

An independent braking system might also be necessary to prevent unintentional movement (e.g. due to wind forces).

The shock load coefficient S_d for such secondary devices shall be less than three.

9.2.4 Manual drive

The maximum force necessary to be applied to the end of a crank in operation shall not exceed 250 N.

9.2.5 Powered drives

9.2.5.1 Powered drive systems shall be designed and arranged in such a way that the A-weighted emission sound pressure level measured at a distance of 1 m from the source is as low as possible, and at least less than or equal to 80 decibels (dB).

9.2.5.2 If powered and manual drive systems are provided for the same movement interlocks shall prevent both systems being engaged at the same time.

9.2.5.3 SAE powered by batteries

9.2.5.3.1 The control box shall be fitted with an indicator that shows the charging level of the batteries. When the charging level falls to a minimum preset value only movements that enable the operator to reach a position to exit the platform shall be possible.

9.2.5.3.2 Batteries shall be enclosed inside a ventilated box.

9.2.5.3.3 Charging of batteries shall only be possible in the parked or other designated position. When the batteries are connected to the power supply an electrical interlock shall prevent any movement of the SAE.

9.2.6 Telescopic jib systems

9.2.6.1 If a failure of the drive system used for the telescoping movement of a jib would cause the suspended platform to fall a secondary device shall be fitted. Any failure of the drive system shall be detected and further movement prevented.

9.2.6.2 If more than one wire rope or chain is attached at one point a device shall be provided for equalizing the tension. It shall be possible to independently adjust the tension of each wire rope or chain.

9.2.7 Chain drive systems

Chain drives shall have a device or system that, in the event of a chain drive system failing, limits the vertical movement of a fully loaded, suspended platform to 500 mm. This requirement shall be met by one of the following:

- a) A single chain drive system with a working coefficient of at least five plus a mechanical safety device operating by engaging with the extending structure. This safety device shall bring the platform plus the rated load to a stop and hold it in the event of the drive system failing. The average deceleration shall not exceed $a = 10 \text{ m/s}^2$ (1 g). Any spring operating this device shall be a guided compression spring with secured ends or with a wire diameter more than half the pitch in the operating condition to limit the shortening of the spring if it should fail.
- b) Two chain drive systems, each system having a working coefficient of at least four (a total of eight minimum) in conjunction with a device to ensure approximately equal tension in the two chain systems.
- c) Two chain drive systems, the first system with a working coefficient of at least five when carrying the full load and a second drive system with a working coefficient of at least four (a total of nine minimum when carrying the full load) and with a device to ensure that the second system takes less than half the load in the operating condition but is able to take the full load if the first system fails.

Any failure in the first system shall be self-revealing.

Round link chains shall not be used.

The minimum breaking load of the chain shall be shown on a certificate.

The junction between the chain and the chain termination shall be able to resist at least 100 % of the minimum breaking load of the chain.

Suitably positioned inspection hatches shall be provided to enable visual examination of chains and chain terminations without the removal of the chains or any major disassembly of structural components. Detailed instructions shall be provided to enable these examinations to be carried out.

Means shall be provided to prevent unintentional displacement of a chain from the sprockets of pulleys, even under slack chain conditions.

9.2.8 Screw jacking systems

9.2.8.1 Secondary devices

Screws shall have a load-bearing nut and if failure or excessive wear of the load-bearing nut would cause a fall of a platform a secondary device shall be provided. The secondary device shall only be loaded if the load-bearing nut fails. Any failure of a load-bearing nut shall be detected and further movement prevented.

9.2.8.2 Inspection facilities for load bearing nuts

It should be possible to detect the wear of load bearing nuts without major disassembly.

9.2.8.3 Travel limitation of the nuts

Screws shall be fitted with devices at both ends to prevent the load bearing and secondary nuts from leaving the screw.

9.2.9 Rack and pinion drive systems

9.2.9.1 Secondary devices

If the failure of a rack and pinion drive system would cause a fall of the platform a secondary device shall be provided. Any failure of the rack and pinion drive system shall therefore be detected and further movement prevented. It should be possible to periodically verify the effectiveness of such devices in service.

9.2.9.2 Rack and pinion guides

In addition to the guide rollers, positive and effective devices shall be provided to prevent any driving or safety device pinion from disengaging from the rack. These devices shall ensure that axial movement of the pinion is so limited that a minimum of $\frac{2}{3}$ of a tooth width is always in engagement with the rack. They shall also restrain radial movement of the pinion from its normal meshing position by more than $\frac{1}{3}$ of the tooth depth.

9.2.9.3 Inspection facilities of pinions

Suitably positioned inspection hatches should be provided to enable visual examination of pinions without the removal of the pinions or major disassembly of structural components of the SAE.

9.2.10 Hydraulic drive systems

9.2.10.1 Cylinders

The telescoping sections of hydraulic cylinders shall be designed in such a way that the pistons cannot leave the cylinders. Mechanical end stops shall be provided for this purpose.

Load holding hydraulic cylinders shall be equipped with a pilot-operated or rupture valve which prevents fluid leaving the cylinder, in case of a pipe failure or failure of a compensating pipe, until the valve is opened by an external force. If pilot-operated or rupture valves are fitted as a secondary device they shall be either:

- a) an integral part of the cylinder; or
- b) directly and rigidly flange-mounted; or

- c) placed close to the cylinder and connected to it by means of short rigid pipes having welded, flanged or threaded connections.

9.2.10.2 Hydraulic Drives

Hydraulic pressure shall be available at all drives to fulfil all functions. Loss of hydraulic pressure shall not result in a hazard. If a leak occurs the service brake shall hold the load.

9.2.11 Pneumatic drive systems

9.2.11.1 Pneumatic drives

Pneumatic drives shall be designed so that ice formation in the system shall be prevented, for example, by using de-icing fluids.

There can be significant differences in the lifting and lowering speeds with pneumatic motors. The particular maximum speed shall be taken into consideration when rating the SAE.

Air pressure shall be available at all pneumatic drives to fulfil all functions. Loss of pressure shall not result in a hazard. Maintenance units that incorporate filters, pressure limiters and/or oilers shall be provided between the main supply and drives.

9.2.11.2 Pneumatic cylinders

Pneumatic cylinders shall not be used for load carrying purposes.

9.3 Permanent suspension rigs

9.3.1 Trolley units

9.3.1.1 Trolley units can move either:

- on a rail or rail track; or
- on a specially made concrete runway or track.

9.3.1.2 Trolley units shall be provided with guide rollers, flanged wheels or other means to ensure the trolley unit stays on the track.

9.3.1.3 If a trolley unit deviates from the track or a wheel assembly fails a device shall be provided to prevent the trolley unit overturning.

9.3.1.4 Mechanical end stops shall be provided to prevent the trolley unit leaving the track way. All end stops shall be positively connected to the rails/tracks and their connections shall not rely on friction.

9.3.2 Clearance

There should be adequate clearance between the rear of a roof trolley and any adjacent portions of the building or any other adjacent fixed structure to reduce the risk of persons being trapped or crushed. A minimum clearance of 0,5 m width and 1,8 m height is recommended. Where such clearance is not possible other measures shall be taken and information on the risks provided by the manufacturer or supplier of the SAE to the user to guard against trapping.

NOTE See also Introduction.

9.3.3 Powered traversing

The nominal horizontal traversing speed shall not exceed 0,3 m/s measured at the trolley unit and at the platform.

The service brake shall stop the trolley and maintain it in a stationary position taking into account the wind force in service and in the parked position. If necessary a storm clamp or similar device shall be provided to attach the trolley unit to the track way in its parked position (see Clause 6 for calculation).

During traversing of a roof trolley an audible signal shall warn persons at roof level that the trolley unit is moving.

Protection bars shall be attached to the wheel units of roof trolleys to prevent feet being trapped. The distance between the bars and the rail track or runway shall not exceed 20 mm.

9.3.4 Jib(s)

Where jib(s) change position by slewing, luffing or telescoping the platform shall not move faster than 0,3 m/s in any direction.

9.3.5 Slewing

The service brake shall stop the jib and maintain it in a stationary position taking into account the wind force in service and in the parked position. If necessary, a clamp or similar device shall be provided to attach the jib to the frame of the trolley or to the track way in its parked position (see Clause 6 for calculation).

9.3.6 Counterweights

When separate counterweights are used to achieve stability of a trolley unit they shall be permanently attached so that it is only possible to remove them by intentional intervention.

9.3.7 Covers and guards

The guarding of machinery contained within SAE (e.g. hoist(s), hydraulic power pack, slewing mechanism, control box) shall be designed to guard the equipment and moving parts from accidental contact with persons. Their fixing systems shall remain attached to the guards or to the machinery when the guards are removed.

When open, the covers and guards shall not conceal any danger signs, warnings, instructions or other notices.

The machinery contained within a suspension rig shall be designed and assembled so that it can be maintained safely. It should also be possible to gain access to the controls and other equipment in case of emergency in whatever position the trolley unit might be situated.

NOTE See also Introduction.

9.3.8 Monorail tracks and traversing trolleys

A traversing trolley system on a monorail used as a means of suspension for a platform shall conform to the appropriate requirements of 9.3.1 and with the following specific requirements:

- A means for safe egress of personnel in the event of a loss of power to the equipment shall be provided.
- A device to prevent unintentional traversing of the trolley shall be provided.

9.3.9 Fixed and portable davits

9.3.9.1 If fixed or portable davits are used as the means of suspension of a platform the SAE shall conform to the following requirements:

- The design of a davit shall allow attachment of the wire ropes to the suspension points on the davit from a safe position at roof level without excessive reaching above the roof or over the parapet.
- Rotating davits shall be designed to allow rotation with a manual force not exceeding 250 N per operator.

9.3.9.2 Portable davits

Portable davits which are relocated in one or more working positions shall conform to the following specific requirements:

- To ensure that each operator is not required to apply an effort of more than 250 N to rig and transport the davits consideration shall be given to the self-weight and size of the individual components forming the davit system.
- Portable davits that would require a physical effort in excess of 250 N per operator to relocate them shall be fitted with wheels or other attachments to reduce that effort to or below 250 N.

9.4 Temporary suspension rigs

9.4.1 General

All parts of a temporary suspension rig shall be capable of being reused and re-erected. Components shall not have sharp edges, angles or protruding parts that could cause injury.

Small parts such as anchor pins and retaining clips shall be joined together by a permanent linking connection.

9.4.2 Physical size and weight

Individual components forming parts of the suspension rig shall be as follows:

- Parts that are regularly moved and are to be carried by one person: maximum 25 kg.
- Parts that are to be carried by two persons: maximum 50 kg.

All weights used to form the counterweight of a suspension rig shall be of solid construction (maximum weight 25 kg) and with their weight permanently marked.

9.4.3 Counterweighted suspension beams

This type of beam rests on the roof. The lengths of the inboard and outboard portions are adjustable and clear assembly and rigging instructions shall be fixed permanently to the beam.

Counterweights shall be firmly attached to the beam so that they can only be dislodged by intentional action. They shall be locked to prevent removal by unauthorized persons.

9.4.4 Suspension points

Separate suspension points shall be provided for the suspension wire ropes and the secondary wire ropes (see Figure 20).

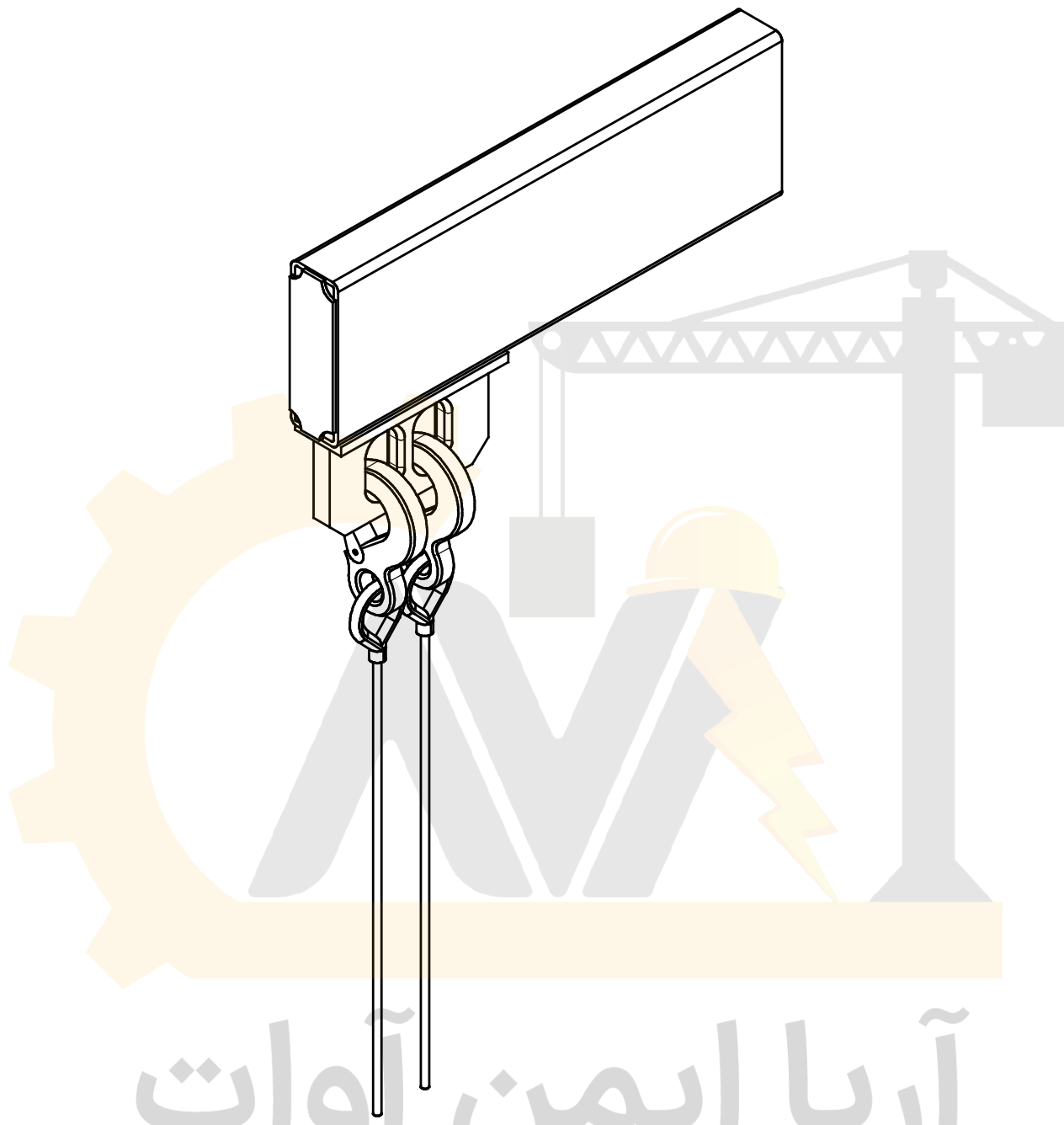

Figure 20 — Example of typical suspension points

10 Electrical, hydraulic and pneumatic systems

10.1 General

Electric systems and components shall conform to EN 60204-1 except where otherwise stated in this standard.

10.2 Measures to monitor 3 phase systems

Means shall be provided to ensure that incorrect phase rotation of the power supply cannot result in an incorrect control response.

10.3 Main power supply protection

Cable based main power supplies shall be protected by over-current protective devices and by a 30 mA residual current device (RCD).

Where busbar systems are installed they should be protected by over-current protective devices and by a 300 mA RCD. Dual pick-ups are recommended.

10.4 Wire ropes with integrated electrical conductors

The conductors shall be not less than 0,5 mm² in cross-sectional area and shall be adequately insulated and protected. The voltage used shall not exceed 240 V.

10.5 Spring loaded or motor powered cable reeler

A limit switch or other system should stop the movement of a trolley before the electric cable is completely unwound from the cable reeler. The cable should be provided with a restraining hook to prevent the tension being exerted through the plug and socket.

10.6 Degrees of protection

All electrical equipment shall conform to EN 60529 and when exposed to open air shall have a protection degree of not less than IP54.

Hydraulic and pneumatic power systems and components shall conform to EN ISO 4413 and EN ISO 4414 respectively.

The fluid system shall be provided with a pressure relief valve fitted between the power source and the first control valve. If different maximum pressures are used in the fluid system more than one pressure relief valve shall be provided.

Pneumatic systems shall be designed so that ice formation in the system can be prevented, for example by using de-icing fluids.

Hoses, including fittings, shall have a bursting pressure not less than three times their maximum working pressure.

All other parts of the fluid system shall be designed to withstand at least twice the maximum pressure to which they will be subjected.

10.7 All safety devices incorporated into SAE shall be designed to be tested in a safe manner.

11 Control systems

11.1 General

11.1.1 SAE shall be provided with robust, hold-to-run controls. The possibility of operators wearing gloves shall be taken into account. The minimum diameter of control buttons shall be 10 mm.

11.1.2 The direction and the movement of all operations shall be clearly indicated on or near each control using words and/or symbols.

11.1.3 Controls shall be located on the platform and arranged in a logical sequence.

11.1.4 Emergency stop buttons that stop the movement of ALL functions and cut the mains power to the roof trolley, suspension rig and/or cradle mounted hoists shall be provided.

11.1.5 The raising and lowering controls for the suspended platform of the SAE shall be located on the platform.

11.1.6 The control of the other power operated functions of the roof trolley or suspension rig (i.e. traversing, slewing, luffing) may also be located in the platform, or in an appropriate position on the roof trolley or suspension rig within easy reach of operators on the platform when it is in its uppermost working position.

11.1.7 Controls shall also be provided on the suspension rig.

11.1.8 Controls shall be provided on the roof trolley or suspension rig at an appropriate position to enable a third party to operate the SAE in the event of a malfunction of the equipment or in an emergency. Such controls shall be protected from unauthorized operation by a lockable selector device.

11.1.9 For SAE with platform mounted hoists and where access to the suspension rig is only possible from the platform itself (i.e. monorails with a manually or power operated traverse mechanism, static davits arms, etc.) it is not necessary to fit duplicate controls of any type on the suspension rig.

11.1.10 Multi-deck platforms shall be provided with their primary controls located on the upper deck. A secondary control station shall be provided on the lower deck and both should be activated to permit raising or lowering of the platform.

11.2 Emergency stop equipment

Emergency stop equipment shall be designed and supplied in accordance with category 0 of EN ISO 13850 and shall be located at each operator control station and any other places where an emergency stop device might be required. All emergency stop devices shall be operative at all times irrespective of the particular control station being used.

11.3 Control of jibs

Where jibs move independently of each other the control circuit shall ensure correct movement so that the platform cannot be inclined more than 14° in any direction.

If necessary, any movement(s) beyond the normal range of working position(s) necessary whilst parking of the machine shall be limited by limit switch(es) operated by a key switch system.

11.4 Safety related parts of control systems for power operated equipment

The control system shall conform to EN ISO 13849-1. The following information is given in this standard is about safety-related parts:

- the category selected;
- the functional characteristics and function in the SAE protective measures.

Table 14 — Safety Requirements for all SAE

Safety related parts	Clause dealt with	Category in accordance with EN ISO 13849-1	Function
Emergency stop equipment	11.2	PL = C	Cut off mains power
Overload detection device 2,5 × RL > TSL (a) 2,5 × RL ≤ TSL (b)	8.3.5	PL = C (a) PL = A (b)	Lifting prevented; lowering allowed, alarm
No load device	8.3.6	PL = B	Lowering prevented,

Safety related parts	Clause dealt with	Category in accordance with EN ISO 13849-1	Function
			lifting allowed
Electrical interlock no power descent system	8.3.4.5	PL = A	Prevent simultaneous manual and powered drive of hoist. Cut off mains power contactor
Overload detection device material winch	8.12	PL = C	Lifting prevented lowering allowed, alarm
Anti-tilt device	8.3.8	PL=B	Maintain longitudinal level of platform
Spooling system of hoist drum and winder	8.4.3	PL = B	Cut off power to hoist
Lifting limit switch			Lifting prevented. Lowering allowed.
With ultimate limit switch (BMU) a)	8.3.10.1	PL = A (a)	This switch operates as an interlock to permit other operations (e.g. traversing, slewing, luffing, telescoping).
Without ultimate limit switch (TSAE, b)	8.3.10.1	PL = C (b)	
Ultimate lifting limit switch	8.3.10.3	PL = C	Cut off power to hoist
Lowering limit switch	8.3.10.2	PL = A	Lowering prevented, lifting allowed
End of wire rope switch			
BMU	8.3.7	PL = C	Cut off power to hoist
TSP	8.6.2 c)	PL = A	Cut off power to hoist
Secondary brake sensor	8.9.2.6	PL = A	Cut off main power contactor
Travel limit of drive system	7.9.5 9.2.2.2	PL = A	Operation interrupted in direction of travel, but allowed in the opposite direction.
Secondary device sensor on telescopic jib	9.2.6.1	PL = C	Cut off power to telescopic jib
Secondary device sensor on chain drive system	9.2.6.1	PL = C	Cut off power to chain drive system
Secondary device screw jacking system	9.2.8.1	PL = C	Cut off power to screw jacking system
Secondary device rack and pinion drive system	9.2.9.1	PL = C	Cut off power to rack and pinion drive system
Lock valve on hydraulic cylinder	9.2.10.1	PL = C	Rod of cylinder locked until manual intervention to release
Restraint point switch	7.7.3	PL = A	Lowering stopped

Safety related parts	Clause dealt with	Category in accordance with EN ISO 13849-1	Function
Control switch detaching restraint system	7.7.3	PL = C	Operation interrupted in direction of travel, but allowed in the opposite direction
Winder failure sensor When winder visible during use (a) When winder is not visible during use (b)	8.6.2	PL = A (a) PL = C (b)	Cut off power to hoist and winder
Battery level sensor	9.2.5.3.1	PL = A	Indication of battery level
Battery power supply interlock	9.2.5.3.3	PL = A	Prevent movement when batteries under charge
3 phase monitoring	10.2	PL = B	Cut off main power contactor
Cable reeler limit switch	10.5	PL = B	Stops movement at maximum cable length
Control of independent jib	11.3	PL = C	Stops movement at maximum incline of the platform
Limit switch load height material hoist	8.12	PL = C	Operation interrupted in direction of travel, but allowed in the opposite direction
De-rating hoist	6.3.3 8.3.1.2 B.1.6	PL = C	Lifting prevented lowering allowed
Anti-collision device	8.3.9	PL = A	Prevent lowering if obstacle encountered on lowering; lifting allowed.
Overhead anti-collision device	8.3.9	PL = A	Prevent hoisting if obstacle encountered; lowering allowed

A competent person should ensure the integrity of all safety functions every time the SAE is put into service.

11.5 Wireless control systems

Wireless controls shall be designed in accordance with EN 60204-32:2008, 9.2.7.

The requirements for wireless control systems are given in Annex F.

For normal operation of SAE, the wireless control station shall be located on the platform. Certain movements of some SAE shall only be possible when the wireless control station is located in a position specified by the manufacturer of the SAE.

12 Verification and certification

12.1 Type verification

12.1.1 General

Verification of SAE shall be carried out before a machine or series of machines is put into service.

Type verification shall be carried out on SAE and/or SAE components (one or several representative samples) before launching series production. In the case of modular equipment type verification shall be carried out on the most unfavourable configuration.

Type verification shall consist of:

- design checks (see 12.1.2);
- type tests (see 12.1.3).

12.1.2 Design checks

The design check shall verify that the SAE is designed in accordance with this standard. It will include a check of the following documents:

- a) drawings indicating the main dimensions of the SAE;
- b) description of the SAE with necessary information about its capabilities;
- c) information about the materials used;
- d) diagrams of the electrical, hydraulic and pneumatic circuits;
- e) operating instructions.

The above documents shall give all necessary information to enable:

- the stability calculations to be checked (see Clause 6);
- the structural calculations to be checked (see Clause 6).

12.1.3 Type Tests

Type tests are described in Annexes A, B and C. Tests shall be performed to check that:

- the SAE is stable;
- the SAE is structurally sound;
- all functions work correctly in accordance with the criteria set out in this standard.

Tests shall be executed on the complete installation. If safety components are available as separate components these may also be type tested separately.

12.2 Manufacturing check

The SAE shall be checked to verify the following:

- the SAE is manufactured in accordance with the design documents;

- the components are in accordance with the drawings;
- certificates are available for each suspension and safety rope or chain (including their terminations) and hydraulic or pneumatic hoses. These certificates shall indicate the minimum breaking load or bursting pressure as appropriate;
- welding has been performed by qualified operatives in accordance with the relevant welding procedures;
- construction and installation of safety devices are in accordance with this standard.

12.3 Installation checks for safety critical track supports and fixings

During installation of SAE and their associated track and track support systems checks shall be made to confirm that all aspects of the system have been correctly installed in accordance with the specification, drawings and relevant technical data.

It is essential that if safety critical items (e.g. U or J bolts) have been provided 'free-issue' to a contractor by a BMU supplier for casting into a concrete structure then the contractor or other controlling body shall issue a certificate confirming correct installation of these items.

A 100 % visual examination of all track anchorage fixings shall be carried out during the construction/installation period to ensure the correct installation of all components and fixings with special attention being paid to components, fixings and connections to structures that will subsequently be hidden.

Where chemical or expanding mechanical anchors that will remain visible and be subjected to shear or tensile forces have been used a representative sample of 20 % of these fixings shall be subjected to torque testing and/or pull-out testing as appropriate.

Where chemical or expanding mechanical anchors that will become hidden and be subjected to shear or tensile forces have been used 100 % of these fixings shall be subjected to torque testing and/or pull-out testing as appropriate.

Pull-out or torque tests shall achieve a tension in the fixing of $0,83 \times R_v$ or $0,83 \times R_h$.

The results of all examinations, checks and tests shall be recorded and collected in a report (with the name, date and qualification(s) of the person(s) carrying out the examinations, checks and tests).

12.4 Verification of BMU systems on site

Verification of BMU systems shall be carried out on site by the manufacturer or authorized representative on the complete installation in its working configuration.

Where safety of the system is reliant on correct installation a thorough examination report confirming that the complete SAE system has been correctly installed and is safe for service should be available prior to the verification of the BMU system. The BMU system may therefore include components not covered by the type tests within this standard such as cast-in, welded or other not readily accessible track fixings and joints in rail track systems. The competent person responsible for the verification should have personally carried out examinations of any fixing details that have become partially or fully inaccessible during the installation or be able to refer to suitably reliable documentation confirming correct installation. It is essential this competent person is sufficiently independent to allow objective decisions to be made.

It is then necessary to perform static and dynamic tests to confirm that the BMU has been correctly manufactured, assembled and installed, fulfils the contractual performance requirements and that all safety devices are operating correctly before the BMU is handed over for service. The static test coefficients are 1,5 of the rated load of the platform plus 1,25 of the working load limit of any additional materials hoist. The dynamic coefficient is 1,1 for both the platform and materials hoist (when fitted).

The results of all verification checks/tests shall be recorded in a report (with the name, date and qualification of the person(s) carrying out the surveys and checks).

12.5 Verification after first assembly of TSAE on site

The objective is to carry out an examination and perform tests as appropriate to confirm that the TSAE has been correctly assembled, fulfils the particular performance requirements and that the safety devices are operating correctly.

A competent person shall then issue a handover certificate to verify the complete TSAE on site prior to use.

12.6 Hybrid systems

Where a TSP is suspended from a permanently installed suspension rig it is the responsibility of the supplier of the TSP to ensure that the total suspended load (TSL) imposed by the TSP on the suspension rig does not exceed the WLL of the rig.

13 Marking of SAE

13.1 General

13.1.1 Signs and plates

One or more clear and durable signs or plates shall be mounted on all platforms and suspension rigs giving the following information:

13.1.2 All types of SAE

- Designation of machine as SAE conforming to this standard;
- name and address of the manufacturer and the manufacturer's representative where applicable;
- designation of series or type;
- serial number (if existing).

13.1.3 BMUs incorporating dedicated platforms

- RL of the platform and the maximum number of persons;
- where applicable, the RLMH of the materials hoist;
- year of completion of manufacture.

13.1.4 BMUs incorporating demountable platforms

- The self-weight, RL (i.e. the TSL) and maximum number of persons;
- the WLL of any suspension rig used in conjunction with a demountable cradle;
- where applicable, the RLMH of the materials hoist.

13.1.5 TSPs

- A table showing the RL of the platform and the maximum number of persons in accordance with the platform dimensions;
- WLL of the hoist(s) to be compatible with the platform;

- where applicable, the maximum safe working load on the cantilevered deck and maximum length of the cantilevered deck;
- where applicable, a diagrammatic label showing the different platform configurations;
- for TSPs, where separate components are utilized, additional information to provide traceability on major component shall be provided.

13.1.6 Platforms

- Name and address of the platform manufacturer;
- name and address of the platform supplier;
- indication of safety harness attachment point(s), when fitted;
- all other markings to be in accordance with 13.1.2 and 13.1.5.

13.2 Manual hoists

- WLL;
- diameter and specification of wire rope to be used.

13.3 Powered hoists

- WLL;
- diameter and specification of wire rope to be used;
- rated hoist speed;
- power supply information if the prime mover is an electrical motor (i.e. voltage (V), current (A), frequency (Hz), power (kW) and motor rated speed (rpm));
- power supply information if the prime mover is a pneumatic motor (i.e. working pressure when lifting the WLL (bar), air flow (dm³/s) and motor rated speed (rpm));
- power supply information if the prime mover is a hydraulic motor or cylinder (i.e. working pressure when lifting the WLL (bar), fluid flow (dm³/s), motor rated speed (rpm) and cylinder travel speed (cm/s)).

13.4 Secondary devices

- WLL;
- diameter of wire rope;
- triggering speed (m/min) if applicable.

13.5 Suspension rigs for TSP

- a) The WLL of the hoist(s) shall be compatible with the WLL of the suspension rig;
- b) if the stability is provided by counterweights; sketches and tables showing the number of counterweights and their weights in accordance with:
 - 1) the WLL of the hoist;

- 2) the length of outboard portion (Lo);
 - 3) the length of inboard portion (Li).
- c) for parapet clamps; a sketch and table showing the supports reaction in accordance with:
- 1) the WLL of the hoist;
 - 2) the length of outboard portion (Lo);
 - 3) the distance between the supports (Ls).

14 Accompanying documents

14.1 General

Instructions shall conform to EN ISO 12100:2010, 6.4.5 and include information about the static and dynamic tests performed on the SAE. The instructions shall be either 'Original Instructions' or a 'Translation of the Original Instructions' in which case the translation shall be accompanied by a copy of the original instructions.

The instructions should be drafted in one or more official Community languages. The words 'Original instructions' shall appear on other language version(s) if verified by the manufacturer or authorized representative.

Where no 'Original instructions' exist in the official language/s of the country where the machinery is to be used, a translation into that/those language(s) should be provided by the manufacturer or authorized representative or by the person bringing the machinery into the language area in question. These translations should bear the words 'Translation of the original instructions'.

The contents of the instructions should cover not only the intended use of the machinery but also warn against misuse.

The wording and layout of the instructions for use should take into account the level of general education and knowledge that can reasonably be expected from such operators of SAE.

Any items necessary for the operation and routine inspection by users of SAE should be supplied with the SAE.

All SAE should be regularly checked and serviced by the manufacturer or another suitably qualified company who should have available all the necessary knowledge, tools and any special equipment.

The maintenance frequency should be based on the level of use of the particular SAE and the recommendations of the manufacturer.

14.2 Manuals

14.2.1 General

The manual shall include instructions about the following where applicable:

- a general description of the equipment;
- restrictions on the use by operators;
- instructions on the need to read and understand the manual;
- information about hazards relating to working at height and the importance of following the operating instructions;

- advice about checking that TSAE is correctly counterweighted;
- information about regular inspection and maintenance;
- information about inclement weather conditions: maximum wind speed, range of ambient temperature, lightning;
- advice about checking for obstructions along the travel of the trolley and platform;
- advice about trapping hazards when the clearance between the building and trolley unit is small;
- advice about the exclusions (see 1.3);
- information about the residual risks that remain despite the inherent safe design measures, safeguarding and complementary protective measures adopted;
- specifications of the spare parts to be used.

14.2.2 Information relating to transport and handling of the SAE:

- Total mass of the equipment and of the main parts which can be dismantled for transport;
- indications for handling (e.g. drawings indicating points for hoisting equipment).

14.2.3 Information relating to the installation, commissioning and reassembly of the equipment:

- Where track and restraint systems are used discussions shall take place between the interested parties to determine the optimum design;
- maximum loads imposed by the suspension rig on the building;
- rail fixing/anchoring requirements;
- assembly and disassembly instructions;
- information shall be given to prevent mixing of inappropriate components;
- space needed for the operation and maintenance of the SAE;
- information regarding the power supply and protective bonding (earth continuity);
- wire rope rigging instructions;
- instructions to ensure that suspension rig is directly above the platform;
- instructions about the need for verification by a competent person before use;
- the need for protection regarding hazardous areas around the SAE.

14.2.4 Information relating to the SAE itself

- The limitations of use (e.g. FEM group of structure and mechanism, operating height, wind speed in service and out-of-service and temperature range);
- detailed description of the equipment and its safety devices – the text should be illustrated with pictures or sketches;

- comprehensive range of examples of applications for which the equipment is intended including prohibited usages if any and foreseeable misuse;
- schematic representation of safety functions as defined in EN ISO 12100-1;

EXAMPLE Failures causing the operation of the fall arrest device:

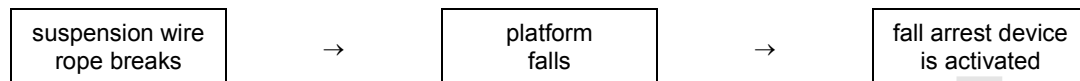

- documents confirming that the equipment complies with this standard.

14.2.5 Information relating to the use of the equipment:

- Description of manual controls;
- means for stopping (especially emergency stop);
- to instruct the operator that he shall stop working and notify his supervisor if faults, damage or other circumstances might jeopardize safety;
- description of how to operate the no-power descent;
- instructions concerning actions the operator shall take if the secondary device is activated;
- information about the means of communication between the platform and a competent person;
- how to prevent undue swaying of the platform while in use;
- instructions for fault identification and the corrective action to be taken in table form (fault, cause, remedy);
- instructions on personal protective equipment to be used;
- information about the residual risks which cannot be eliminated by design and information on safety measures to be taken by the operator.

For SAE all hazards related to a platform encountering obstructions are not completely covered by the devices described in 8.3.9. Operator(s) shall always ensure that there are no obstructions along the travel of a trolley and platform.

Overload detection devices in accordance with 8.3.5 might not protect TSP in all configurations. Operator(s) shall always ensure that the loading of a platform is in accordance with the RL indicated on the plate.

- Information about daily inspections;
- for TSPs, the following additional checks are required:
 - each day, before TSP is put into use, the operator shall check that the operating devices, brakes, secondary devices and emergency switches function correctly;
 - the condition of all trailing cables, limit switches, structural platform parts and wire ropes shall also be checked;
 - check security of the suspension rig and ensure that no counterweights have been removed;

- ensure that the suspension point is directly above the intended position of each platform mounted hoist in order to avoid excessive horizontal forces on the suspension rig and sway of the platform;
- ensure that any snow, ice, debris or surplus material does not accumulate on the platform;
- ensure that objects which could come into contact with the platform do not project outside the facade;
- when the work is finished the operator shall move the TSAE to the "out-of-service" position, switch off and isolate from mains supply to prevent unauthorized use.
- fall arrest devices shall not be used to stop the platform during in-service conditions;
- instructions for the owner to keep a logbook which contains the following:
 - name of the competent person in charge of the SAE;
 - date and name of operator(s) using the SAE;
 - for TSAE, serial numbers of hoists and secondary devices;
 - number of hours the SAE is in service;
 - specification of wire ropes;
 - number of hours wire ropes are in use;
 - record of any reportable incident and the action taken;
 - dates of periodic inspections and records of the outcome.
- use at specific locations where limitations on use may be required;
- parking the SAE in the "out-of-service" position.

14.2.6 Information for maintenance:

Maintenance should only be carried out by the manufacturer or another suitably qualified company who should have all the necessary knowledge, tools and any special equipment available. This should include:

- maintenance and repair records should be kept in the logbook;
- drawings and diagrams enabling maintenance personnel to carry out their task;
- wire rope specification prescribed by the manufacturer;
- certificates of wire ropes shall be kept;
- warnings shall be given regarding the dismantling of spring-loaded reelers or winders;
- information about replacement criteria for wire ropes and all components subject to wear;
- checks on the integrity of any seal on the setting element of an overload or secondary device.

Annex A (normative)

Platform type-tests

A.1 General

Platform tests shall reflect the actual load configurations, as given in Clause 6, testing the ultimate strength taking into account the working coefficient for each component.

A.2 Maximum deflection type-test

The platform shall be supported directly underneath the stirrups.

The deck of the platform is then subjected to a load equal to the RL distributed over the total width of the platform. The RL is applied gradually in the most unfavourable position as shown in Figure A.1 below.

The load is then removed and reapplied as before for 15 min.

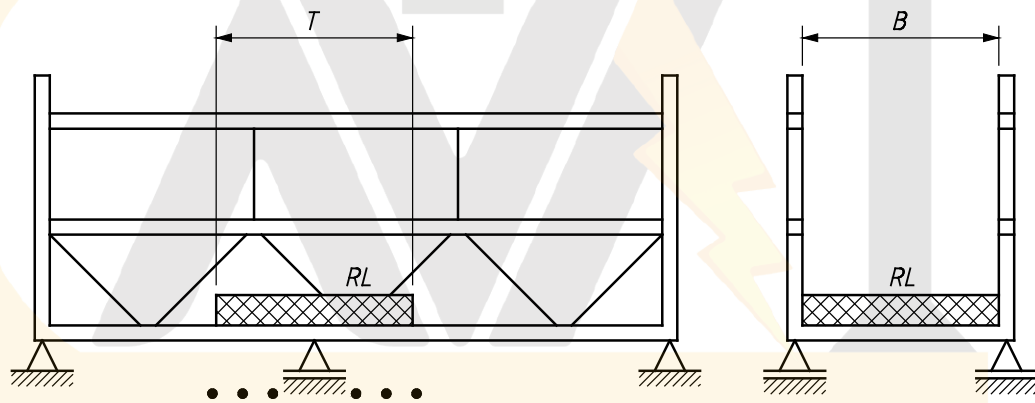

Figure A.1 — RL distribution

See 6.3.4 for the calculation of the RL.

The deflection induced by the load shall be measured and recorded.

The value 'a' of the deflection caused by the load shall not exceed:

$$a \leq \frac{L}{200}$$

After removing the load the residual deflection is checked after a period of three minutes. The value 'b' of the residual deflection shall not exceed:

$$b \leq \frac{L}{1000}$$

A.3 Tests of cantilevered platform

A.3.1 Maximum deflection type-test

The platform shall be supported directly underneath the stirrups. The cantilevered section is then subjected to a load equal to W distributed over the total width of the platform and which is applied gradually (see 6.3.4.5 for the calculation of W). The load is then removed and reapplied as before for 15 min. The deflection induced by the load shall be measured and recorded. The value "a" of the deflection caused by the load shall not exceed:

$$a \leq \frac{Lc}{100}$$

After removing the load the residual deflection is checked after a period of three minutes. The value 'b' of the residual deflection shall not exceed:

$$b \leq \frac{Lc}{1000}$$



Figure A.2 — Cantilevered section loaded

A.3.2 Stability type test

The cantilevered section is subjected to a load equal to twice W applied gradually. The platform shall remain stable.

A.4 Static test of the platform

A.4.1 General

The static test coefficient is equal to 1,5.

A.4.2 Horizontal deck

The platform shall be suspended by its stirrups in a horizontal position.

The distribution of the load is identical to A.1.

The deck of the platform is subjected to a load equal to $1.5 \times RL$.

The load is applied gradually in the most unfavourable position. The load is distributed along the length T in accordance with Formula (4).

The load is applied for 15 min.

A.4.3 Sloped deck

The platform shall be suspended by its stirrups in a horizontal position. The stirrup at one end shall be raised so that the deck is at an incline of 14° to the horizontal. The load and its distribution are identical to the test in A.1.

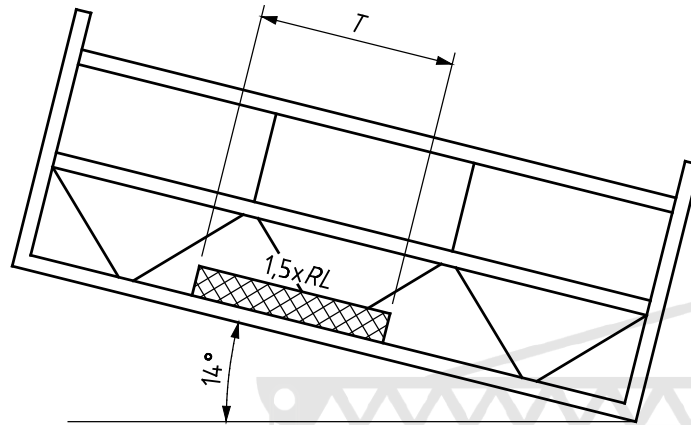

Figure A.3 — Platform sloped lengthwise

Interpretation of the results:

The platform is considered satisfactory if the static test causes no failure or visible damage to the structure and if the value 'a' of the deflection caused by the load does not exceed:

$$a \leq \frac{L}{130}$$

After removing the load the residual deflection shall not exceed:

$$b \leq \frac{L}{1000}$$

A.5 Dynamic test of the platform

The dynamic test coefficient is equal to 1,25.

The platform is attached to the wire ropes and lifted and lowered at the rated speed of the hoist.

The deck of the platform is subjected to a load equal to $1,25 \times RL$. The load is applied gradually and in the most unfavourable position.

The load is distributed along the length T in accordance with Formula (4).

The dynamic test is carried out for 30 cycles over a minimum lifting height of 1 m.

Interpretation of the results:

The platform is considered satisfactory if the dynamic test causes no failure or visible damage to the structure.

A.6 Ultimate load type-tests

The platform shall be suspended by its stirrups in a horizontal position.

The deck of the platform is subjected to a load equal to $3 \times RL$.

The load is applied gradually in the most unfavourable position. The load is distributed along the length T in accordance with Formula (4).

Application time: 1 hour.

Interpretation of the results:

The strength of the platform is considered adequate if load bearing and non-load bearing parts of the platform suffer permanent deformation but do not break.

A.7 Strength type-test of the decking

The decking strength shall be checked with the platform in a horizontal position supported at each end.

A deck shall withstand, without failure, a load of 300 kg distributed over an area of 20 cm × 20 cm.

The load is placed centrally between two adjacent cross-members supporting the deck.

A.8 Strength type-test of the guardrail

A.8.1 Horizontal static test

The platform is suspended from its suspension points and loaded with 1,25 x RL (distribution and location of RL as in A4). The guardrail is then subjected to several horizontal static forces F_h equal to 300 N for each of the first two persons on the platform and 150 N for each additional person.

The forces F_h directed towards the outside are applied gradually without shocks at guardrail level and with a spacing of 500 mm in the most unfavourable positions. Any horizontal deflection is to be measured.

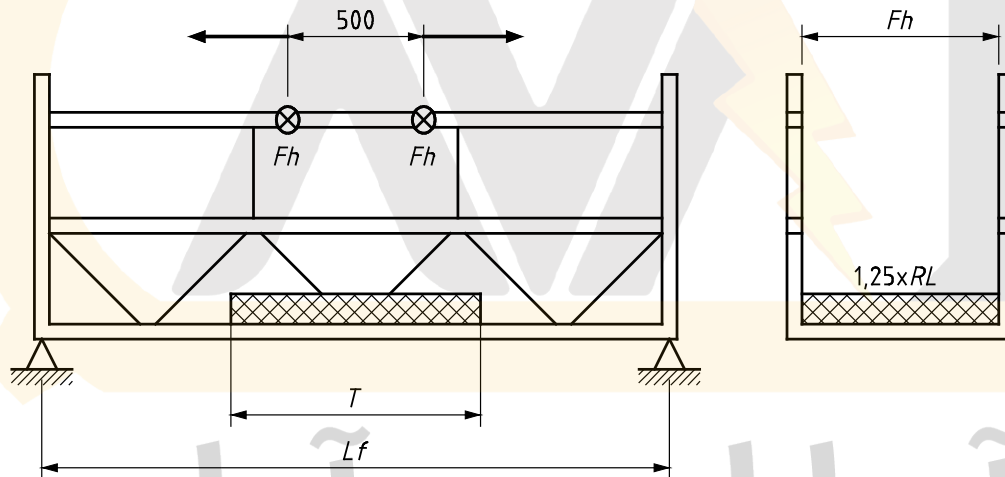

Figure A.4 — Horizontal loads on guard rail

The guardrail is considered satisfactory if there is no visible sign of damage and if the deflection 'a' caused by the load F_h does not exceed:

$$a \leq L_f/100 \text{ (maximum allowable deflection is 30 mm)}$$

A.8.2 Vertical static test

The guardrail is subjected to a vertical static force, where F_v is equal to 1 kN directed downwards and applied gradually without shocks.

The force F_v is applied in the most unfavourable position on a width of 100 mm.

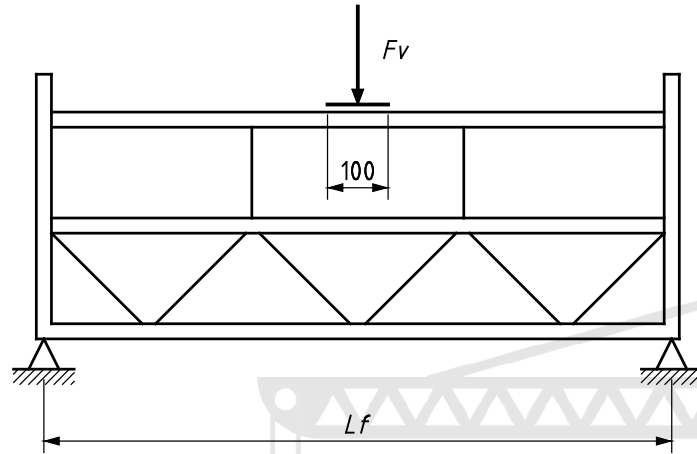

Figure A.5 — Vertical loads on guard rail

The forces F_v are applied for three minutes.

The guardrail is considered satisfactory if there is no visible sign of damage and if after removal of the load the residual deflection 'b' does not exceed:

$$b \leq \frac{L_f}{100}$$

آریا ایمن آوات

Annex B (normative)

Hoist and secondary device type-tests

B.1 All types of hoists and secondary devices

B.1.1 Static test

The static test coefficient is equal to 1,5.

A hoist shall be statically loaded for 15 min to 1,5 times its WLL.

A traction hoist shall not show any signs of the wire rope slipping or creeping through the traction sheave. The wire rope should be lubricated in accordance with the manufacturer's instructions.

The service brake shall hold the load without slipping or creeping.

No load-bearing component of the hoist shall fail, deform or weaken and the load shall be held in position.

After the load is released the hoist should operate in accordance with the manufacturer's instructions.

B.1.2 Dynamic test

The hoist carrying 1,25 times its WLL in a suspended position shall lift and lower for 30 cycles.

The service brake shall stop the descent of a hoist within 10 cm and shall hold the load without slippage.

Drum hoists are to be tested with the maximum number of layers of wire rope specified by the manufacturer wrapped around the drum.

B.1.3 Strength type test

A hoist shall be statically loaded for 15 min to four times its WLL. This test shall be carried out in such a way that no slippage of the wire rope in the traction system occurs and with the prime mover mechanically locked.

Brakes shall be disengaged. No load-bearing component of the hoist shall fail and the load shall be held in position.

After the above tests the traction sheave or the drum shall be rotated through 90° and the test repeated until the traction sheave or drum has been rotated 360°.

B.1.4 Testing the operation of fall arrest device

B.1.4.1 General

The sudden stop experienced by the platform caused by action of the fall arrest device will cause the secondary wire rope and the total load carrying system to be subjected to dynamic forces. The maximum dynamic tensile force (T_m) on the secondary wire rope is expressed as:

$$T_m = S_d \times WLL$$

where

WLL is working load limit of the hoist or the working load limit of the fall arrest device if separate.

If the fall arrest device is part of the SAE the test shall be carried out with the fall arrest device built into the total system.

If the fall arrest device is supplied as a separate unit the test shall be carried out in a test rig. This test rig shall be so constructed that its natural frequency of vibration in the vertical axis at the anchorage point is not less than 100 Hz and so that the application of a force of five times the WLL on the anchorage point does not cause a deflection greater than 1 mm.

The test arrangement for the fall arrest device is given in the Figure B.1 below:

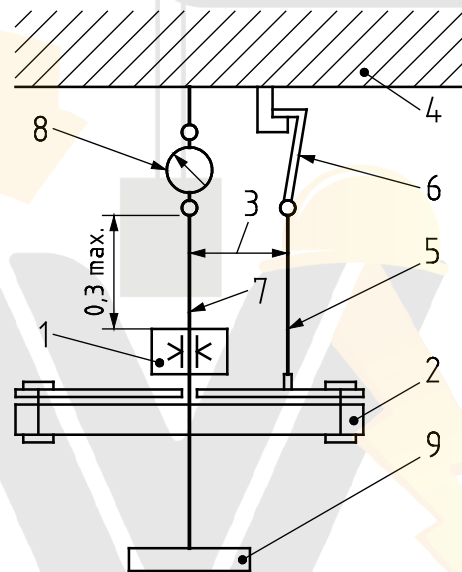

Key

- 1 fall arrest device
- 2 test load
- 3 horizontal distance between ropes
- 4 suspension point
- 5 wire rope
- 6 release device
- 7 secondary rope
- 8 force measurement apparatus
- 9 weight 10 kg

Figure B.1 — Typical test rig for fall arrest device

The length of the wire rope above the fall arrest device shall be limited to a maximum of 30 cm. The distance between the two wire ropes (3) shall be fixed by the design or specified by the manufacturer.

The test load applied shall be the WLL.

B.1.4.2 Force measurement apparatus

The force measuring apparatus shall be capable of measuring forces from the WLL to five times the WLL of the hoist with an accuracy of $\pm 2\%$ and a frequency bandwidth of 1 000 Hz.

B.1.4.3 Test procedure

- a) Mark the secondary wire rope at the point where the secondary wire rope enters into the fall arrest device to enable the drop distance to be measured.
- b) Attach a weight of 10 kg to the lower end of the secondary rope to ensure that it is not slack.
- c) Execute drop test by releasing the load carrying wire rope from its suspension point. Ensure that this occurs without any additional forces affecting the test results. Once released the test load should accelerate down and then come to a complete stop once the fall arrest device catches the secondary wire rope.
- d) Record the drop distance and the maximum dynamic tensile force on the secondary rope.
- e) Repeat steps c) and d) three times consecutively.

B.1.4.4 Test results

- a) A fall arrest device tested with a complete SAE shall conform to the following requirements:
 - 1) the SAE shall withstand three falls without breaking;
 - the shock load coefficient as measured by $Sd = \frac{Tm}{WLL}$ is less or equal to three in each of the three tests;
 - 2) the distance of the drop is less than 50 cm in each of the three tests.
- b) A fall arrest device tested as a separate unit on a test rig as shown in Figure B.1 shall conform to the following requirements:
 - 1) the fall arrest device and the wire rope shall withstand three falls without breaking;
 - 2) the shock load coefficient as measured by Sd shall be less than five in each of the three tests;
 - 3) the distance of the drop shall be less than 50 cm in each of the three tests.

B.1.5 Secondary brake type test

B.1.5.1 General

When a secondary brake is fitted the sudden stop of the platform caused by the operation of the secondary brake will cause a dynamic load in the suspension wire ropes. The maximum traction force Tm in the wire ropes is expressed as:

$$Tm = Sd \times \frac{TSL}{Nr}$$

The secondary brake is part of the SAE and the test shall be carried out with the secondary brake built into the total system. If such a test is not practicable the test shall be carried out in a test rig.

See Figure B.2 Typical test rig for secondary brake.

The hoist (1) without gear, motor and service brake is fitted with a secondary brake (2) and attached to a frame (3). A load (4) representing the TSL including the RL is attached to the suspension wire ropes (5) by force measurement devices (6).

A maximum length of 3 m shall be ensured between the drum and item (6).

The frame (3) shall be so constructed that its natural frequency of vibration in the vertical axis is not less than 100 Hz and so that the application of a force of five times the TSL on the drum bearings does not cause a deflection greater than 1 mm.

For force measurement apparatus, see B.1.4.

The load is supported by supports (7) linked by wire ropes to a drop test device.

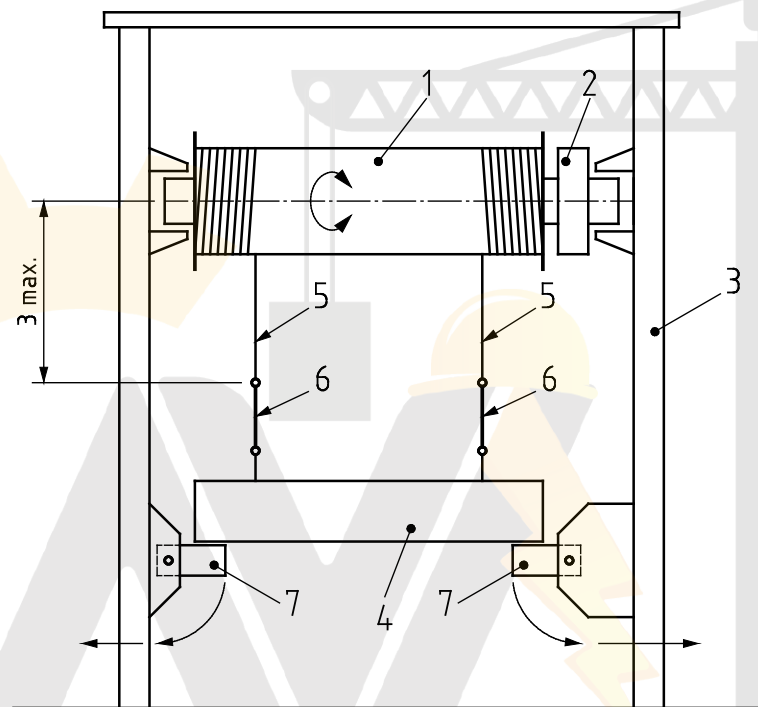

Key

- 1 hoist
- 2 secondary brake
- 3 winch frame
- 4 test load
- 5 suspension wire ropes
- 6 force measurement device
- 7 supports/guides

Figure B.2 — Typical test rig for secondary brake

B.1.5.2 Operating mode

Releasing the drop test device causes the fall of the load.

The force variations in the wire ropes are recorded and the distance of drop is measured.

B.1.5.3 Test results

The secondary brake is considered satisfactory if:

- it withstands three falls without failure;
- the shock load coefficient is less or equal to three;

- the distance of drop is less than 50 cm.

B.1.6 Hoist lifting load limit tests

The motor of a hoist shall be tested (measured) and shall stall at a load less than 2,5 times the WLL of the hoist or be otherwise prevented from lifting a load greater than 2,5 times the WLL (refer to 8.3.1.2).

When carrying out the test the following conditions should apply:

- nominal voltage of the motor;
- normal ambient temperature;
- motor at normal working temperature;
- any additional safety device is in operation (see 8.3.1.2).

B.2 Manual operated hoists

B.2.1 In service operation test

A manual hoist shall lift or lower the WLL with a force applied to the end of the crank or lever not exceeding 250 N or 400 N respectively.

A manual hoist shall not permit lifting a load in excess of 2,5 times the WLL when a force of 625 N or 1 kN is applied to the end of the crank or lever.

B.2.2 Endurance type test

A manual hoist shall operate as intended for 500 cycles while carrying the WLL.

There shall be no signs of breakage, wear or malfunction. No repairs or adjustments shall be necessary.

B.2.3 Wire rope type tests

The wire rope used to carry out the endurance test (see B.2.2):

- a) shall show only 10 visible wire breaks on a length of $30 \times d$;
- b) shall not show bird-caging or breakage of any wire rope strands.

After being subjected to the endurance test neither the wire rope nor its termination shall break when pulled with a force equal to six times the WLL of the hoist.

B.3 Power operated hoists

B.3.1 Endurance type test for hoists

The hoist shall operate as intended in accordance with Table 4:

- 30 000 cycles with $0,5 \times WLL$ for A2;
- 30 000 cycles with $1 \times WLL$ or 60 000 cycles with $0,5 \times WLL$ for A3;
- 60 000 cycles with $1 \times WLL$ for A4.

It is accepted that the wire rope may be replaced every 1 000 cycles (refer to definition 3.4.14).

During this test the brake can be adjusted but should not be repaired.

The rate of cycling shall be adjusted to prevent overheating of the prime mover.

When the cycles are completed the hoist shall be inspected. There shall be no signs of breakage or malfunction. Each wire rope used in the testing procedure shall be inspected in accordance with B.2.3.

B.3.2 Overload detection device type tests

B.3.2.1 Type testing of overload devices should be carried out by the manufacturer of the device and a certificate issued.

B.3.2.2 The test includes a functional test to test the tripping limit. Functional testing of the tripping limit of the overload device should be performed in accordance with the following procedure:

- the platform is on the ground;
- for BMUs the platform is loaded with 1,25 times the RL on a surface Sa located in the vicinity of the stirrup;
- for TSPs the hoists are loaded with 1,25 times their WLL;
- the platform is then raised above the ground – raising shall only be possible for a maximum of 10 cm before the overload device is triggered;
- the platform is unloaded until the overload device resets automatically;
- the platform is then reloaded as before;
- raising shall not be possible when the overload device has been triggered;
- the overload device(s) once triggered shall continuously prevent all movement except lowering;
- the overload indicator shall continuously warn the operator;
- the platform is then lowered to the ground and the overload device shall reset automatically;
- for BMUs, the platform is loaded with its RL on the same location as previously;
- for TSPs, the hoists are loaded with their WLL;
- lifting and lowering shall then be possible.

B.3.2.3 A strength test shall be performed in accordance with the procedure described in B 3.2.2 but with the RL and the WLL multiplied by 1,6. During this test the overload device(s) shall operate in accordance with the manufacturer's instructions.

B.3.3 Electrical type tests

Electrical tests shall be carried out in accordance with EN 60204-1.

Annex C (normative)

Suspension rig type-tests

C.1 Trolley unit

C.1.1 General

For the test of a platform suspended from a suspension rig, see Annex A.

For the test of the hoist part of a suspension rig, see Annex B.

C.1.2 Static test

The suspension rig unit is placed on suitable track(s) or other surface.

The test shall be carried out in the most unfavourable working positions.

The suspension rig shall be loaded with a static test load equal to:

$$W_{ts} = SWP + 2 \times (1,25 \times RL + M_{wr})$$

When installed the materials hoist shall also be loaded simultaneously with a static test load equal to TSHL \times 1,4.

These loads may be higher than load case 3.

The suspension rig is considered satisfactory if it withstands the static test load without breakage or permanent deformation of the structure and remains stable.

C.1.3 Dynamic test

The suspension rig is placed on a suitable track(s) or other surface.

The test shall be carried out in the most unfavourable working positions.

The suspension rig shall be loaded with a dynamic test load equal to:

$$W_{td} = 1,25 \times (RL + M_{wr}) + 1,25 \times SWP$$

When installed the materials hoist shall also be loaded simultaneously with a dynamic test load equal to TSHL \times 1,25.

The test is performed during:

- the lifting movement of the hoists;
- the luffing movement of the jib(s);
- the telescoping movement of the jib;
- the slewing movement of the housing;
- the secondary device(s) shall be tested under simulated emergency conditions;

- The suspension rig is considered satisfactory if:
 - it withstands the dynamic test load without breakage or permanent deformation of the structure and remains stable;
 - all movements are smooth and with a speed not higher than those specified in 9.3.3 and 9.3.4.

C.1.4 Electrical type test

The electrical tests shall be carried out in accordance with EN 60204-1.

C.2 Other suspension rigs

Other suspension rigs that are installed in conjunction with platform-mounted hoist(s) (i.e. roof suspension beam, parapet clamp, fixed davit and monorail) shall be subjected to two forces:

- a vertical force $F_v = 2,5 \times WLL$;
- a horizontal force $F_h = 0,15 \times WLL$ acting in the most unfavourable direction.

WLL is the working load limit of the hoist in N.

The suspension rig is considered satisfactory if:

- it withstands the static load test without breakage or any permanent deformation of the structure and remains stable;
- it remains stationary while supporting the static test load.

آریا ایمن آوات

Annex D (informative)

Guidance on the presentation and interpretation of loads imposed by SAE structures

D.1 General

The design of SAE is governed by three primary load cases with additional stability and anchor strength calculations.

Load case 1 gives the loads transmitted to the superstructure during normal use and shall be considered as the 'working load'.

Load case 2 covers occasional situations such as load testing and storm conditions.

Load case 3 covers exceptional situations such as activation of a safety device.

D.2 General notes for roof mounted suspension rigs

Stability and anchor calculations ensure that an adequate factor of safety is employed to avoid overturning of the SAE. Where a roof mounted suspension rig relies on the track or other anchorage for stability then this uplift force should be given as the superstructure should be capable of resisting this force.

When in service and during storm conditions horizontal loading in both directions will occur and it is essential that these loads should also be identified.

Where an auxiliary hoist is incorporated into SAE then the load cases should include the forces imposed by this additional load.

It is recommended that the following factors be applied by the structural engineer as a minimum to the load cases for the purpose of identifying the design loads for the superstructure. It is the responsibility of the structural engineer however to ensure imposed loads from the SAE are adequately engineered into the superstructure design.

- Load case 1 with $\gamma_f = 1,5$
- Load case 2 with $\gamma_f = 1,33$
- Load case 3 with $\gamma_f = 1,1$
- Horizontal load with $\gamma_f = 1,1$

See also Table G.1.

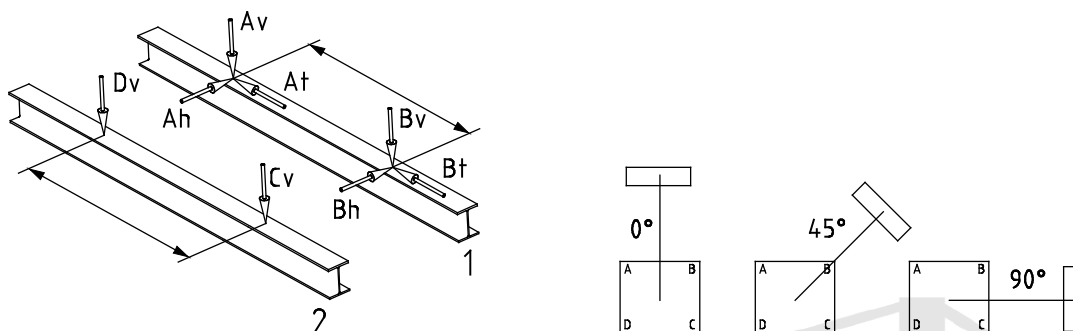

Key

- 1 outboard track
- 2 inboard track

Figure D.1 — Roof mounted suspension rig

Table D.1 — Load table for roof mounted suspension rig

	Load case 1			Stability reaction		
	0°	diagonal	90°	0°	diagonal	90°
Av (kN)						
Bv (kN)						
Cv (kN)						
Dv (kN)						
Ah (kN)						
At (kN)						
Bh (kN)						
Bt (kN)						

D.3 General notes for monorail support brackets and davits:

Load cases 1, 2 and 3 shall be given in respect of direct loads imposed on the supporting bracket/structure. The 'working load' shall be taken as the more onerous of either Load case 1 when multiplied by 1,5 or Load case 2 when multiplied by 1,33.

Where applicable the provision of a secondary hoisting position for an auxiliary hoist should be allowed for in the calculations.

The minimum design load on the fixings shall be given.

The moment M_c on the connection shall be given for all three load cases.

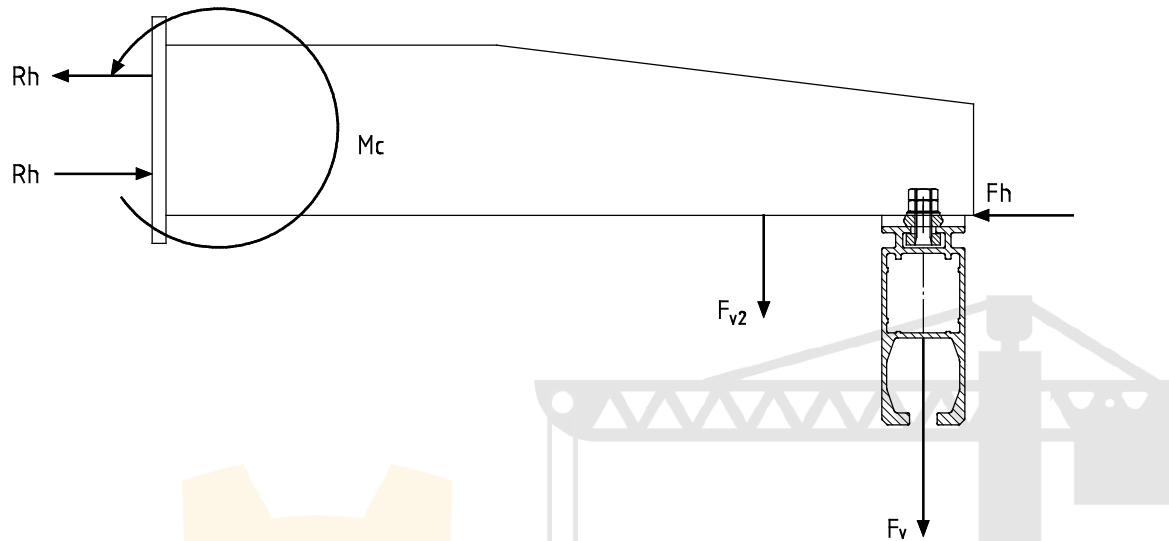

Figure D.2 — Cantilever suspension rig

Table D.2 — Load table for cantilever suspension rig

	Load case 1	Loading case 2	Loading case 3	Anchor design
Fv (kN)				--
Fv2 (kN)				--
Fh (kN)				--
Rh (kN)				
Rv (kN)				

آریا ایمن آوات

Annex E (informative)

Maximum permitted horizontal displacement of platform

E.1 General

A hazard can arise due to horizontal displacement of a suspended platform caused by wind and the resulting uncontrolled swing back against the facade or swinging parallel to the facade.

Assuming that 4 m is the maximum permitted horizontal displacement of a platform and 200 N is the maximum horizontal force one operator can exert the maximum allowable wind speed can be calculated as follows:

H = maximum operating height (free rope length)

Vertical angle of suspension ropes: $\tan \alpha = \frac{4m}{H}$ should be 4 (m) and H (m)

آریا ایمن آوات

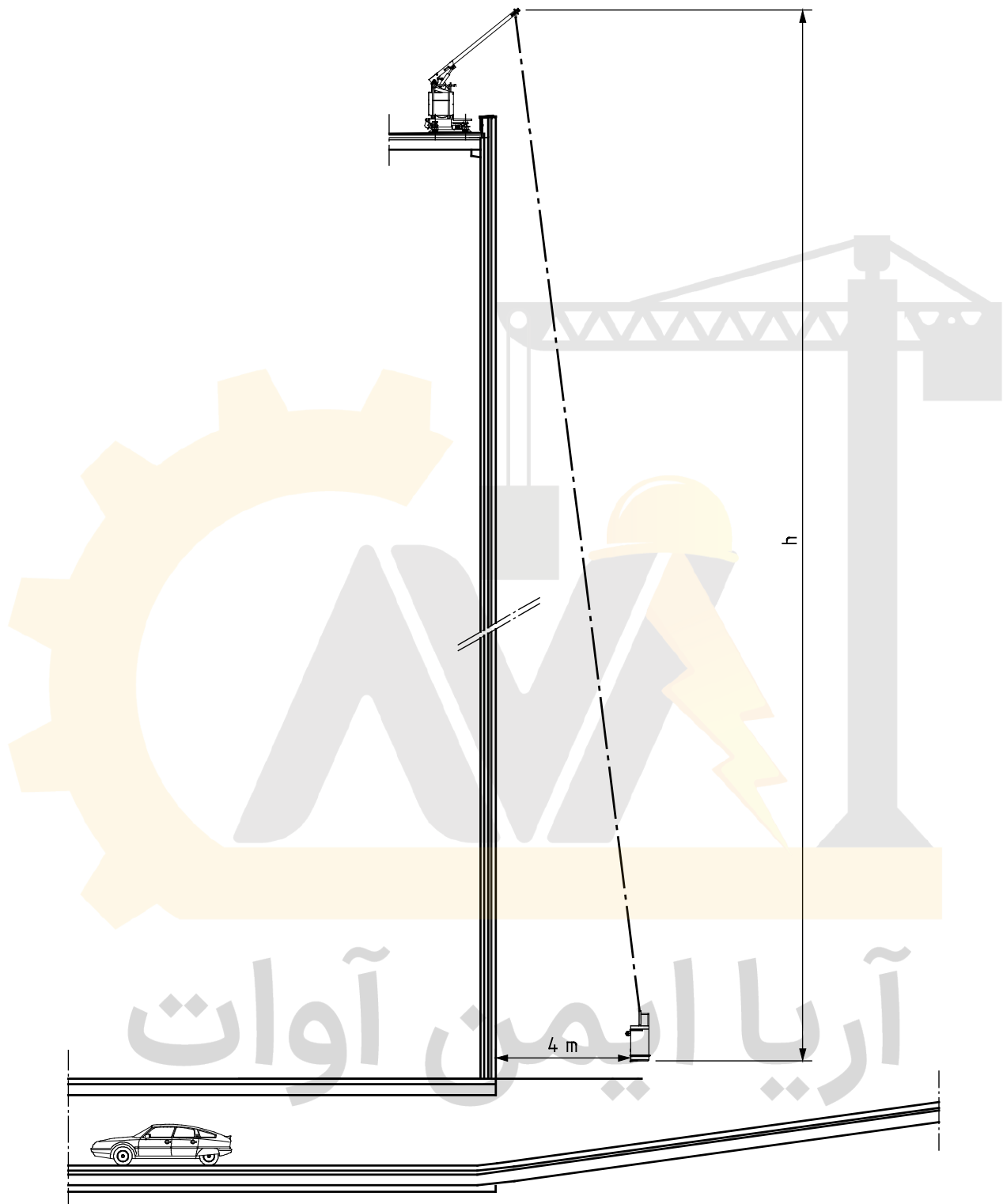

Figure E.1 — Maximum (theoretical) horizontal displacement of platform

The wind load depends on the size, shape and position of the platform as well as the direction and speed of the wind. Ignoring local effects and turbulence a corresponding wind pressure and wind speed can be calculated:

$$q = 0,613 \times v^2$$

where

q is dynamic wind pressure in N/mm^2 ;

v is calculated wind speed in m/s.

$$F_{W \text{ allowed}} = \tan \alpha \times TSL$$

$$v = \sqrt{\frac{F_{W \text{ allowed}}}{0,613 \times Cf \times A}}$$

where

Cf is shape factor to areas exposed to wind;

A is area exposed to the wind (6.3.5).

E.2 Sample calculation - 60 m without restraint:

Two person platform, full cladding

size 2 000 mm long, 1 100 mm high

SWP = 125 kg

RL = 250 kg

Mwr = 40 kg, 60 m Ø6,5 rope

TSL = 415 kg = 4 150 N

$$F_{W \text{ allowed}} = \tan (3,81^\circ) \times TSL = 0,067 \times 4 150 \text{ N} = 277 \text{ N}$$

Two people can handle this force.

Area exposed to the wind:

$$A = 2 \times 0,35 \text{ m}^2 + 2 \text{ m}^2 + 2 \text{ m} \times 1,1 \text{ m} = 4,9 \text{ m}^2$$

For shape factors applied to areas exposed to wind, refer to FEM 1.001, booklet 2

$$F_W = q \times Cf \times A = 0,613 \times v^2 \times 1,55 \times A$$

Box profile, $b/d < 2$, $l/b < 5$, $Cf = 1,55$

$$v = \sqrt{\frac{F_W}{0,613 \times 1,55 \times A}}, F_W = 277 \text{ N}$$

For 60 m height without restraint system, the maximum allowed wind speed shall be 7,7 m/s = 28 km/h.

$$v = \sqrt{\frac{277 \text{ N}}{0,613 \times 1,55 \times 4,9 \text{ m}^2}} = 7,7 \frac{\text{m}}{\text{s}}$$

Parallel displacement:

40 % from 2 m long platform = 800 mm

$$\text{sloping degree } \tan \alpha = \frac{0,8 \text{ m}}{60 \text{ m}} = 0,0133, \alpha = 0,76^\circ$$

$$F_{w \text{ allowed}} = \tan (0,76^\circ) \times TSL = 0,0133 \times 4150 \text{ N} = 55,2 \text{ N}$$

Two people can handle this force.

$$A = 0,35 \text{ m}^2 + 0,6 \text{ m} \times 1,1 \text{ m} = 1,01 \text{ m}^2$$

Area exposed to the wind

For shape factors applied to areas exposed to wind, refer to FEM 1.001, booklet 2.

Box profile, $bd < 2$, $l/b < 5$, $C_f = 1,55$

$$F_w = q \times C_f \times A = 0,613 \times v^2 \times 1,55 \times A$$

$$v = \sqrt{\frac{F_w}{0,613 \times 1,55 \times A}} \quad F_w = 55,2 \text{ N}$$

$$v = \sqrt{\frac{55,2 \text{ N}}{0,613 \times 1,55 \times 1,01 \text{ m}^2}} = 7,58 \frac{\text{m}}{\text{s}}$$

most unfavourable case

For 60 m height without restraint system the maximum wind speed shall be 7,6 m/s = 27 km/h.

آریا ایمن آوات

Annex F (normative)

Guidance on the requirements for wireless control systems

F.1 General

A transmitter should not transmit whilst the means to prevent unauthorized use is activated.

F.2 Control limitation

F.2.1 Activation of the transmitter should be indicated on the transmitter and should not initiate any movement of a BMU.

F.2.2 The receiver should provide output operating commands to the control system only when it is receiving frames containing the right address and correct command.

F.2.3 The main contactor should only be energized (i.e. controlled to the “on” state) by at least one correctly received frame without any operating commands but containing a start command.

F.2.4 To avoid inadvertent movements after any situation having caused the SAE to stop (e.g. power supply fault, battery replacement or lost signal condition), the system should only output operating commands resulting in any SAE movement after the SAE operator has returned the controls to the “off” position for a suitable period of time (i.e. it has received at least one frame without any operating commands).

F.2.5 Whenever the SAE is de-energized all operating command outputs for SAE movements from the receiver should cease.

F.3 Stop

F.3.1 The part of the wireless control system to perform a safety function is a safety related part of the SAEs control system, as defined in EN ISO 13849-1:2008, 3.3.1. This part of the wireless control system should be designed in accordance with Table 14 of this standard or higher for safety performance as defined in EN ISO 13849-1.

F.3.2 The control system should initiate a stop of all SAE movements when no valid frame has been correctly received within 0,5 s.

F.3.3 Unless the receiver monitors that the state of the control system corresponds with the state of the receiver outputs the stop should also de-energize the SAE switch. If the receiver monitors that the state of the control system corresponds with the state of the receiver outputs the de-energizing of the SAE switch may be delayed up to a maximum of 5 min.

F.3.4 If emergency stop functions of category 0, as required in EN 60204-32:2008, 9.2.5.4.2, creates any additional risk the stop function may be of category 1.

F.4 Serial data communication

F.4.1 The frame should be sent repeatedly during operation.

F.4.2 The system should provide a transmission reliability to a hamming distance of the total number of bits in a frame divided by 20 and at least four, or other means, which ensure an equal level of reliability such that the probability of an erroneous frame getting through is less than $10 E-8$.

F.5 Use of more than one operator control station

F.5.1 Transfer of control from one transmitter to another should not be possible until the first transmitter has been deactivated by a deliberate action specifically designed for this purpose.

F.5.2 Means should be provided to enable several transmitter/receiver pairs to operate in the transmission range without unwanted interference with each other.

F.5.3 The means provided in F.5.2 should be protected from accidental or unintentional change.

F.6 Battery-powered operator control stations

After the warning and the period required in EN 60204-32:2008, 9.2.7.6 (when the transmitter battery voltage becomes so low that a reliable transmission becomes unreliable) the transmitter should go automatically to the locked-off condition (i.e. the receiver stops all SAE motions and de-energizes the SAE switch).

F.7 Receiver

The receiver should withstand the vibration random wide band test in EN 60068-2-64, Test Fd.

F.8 Warnings

Where persons can be expected to be in the vicinity of the SAE or a part of the SAE (e.g. travelling SAE, slewing SAE) and the risk exists of persons being trapped or run over then warnings should be provided.

The SAE should be provided with:

- a) a marking on the access to the SAE stating that the SAE is provided with a wireless control system and:
- b) either:
 - 1) a continuous visual warning while a wireless control system is operating; or
 - 2) an automatic acoustic and/or visual warning prior to any movements of the SAE.

F.9 Information for use

Instructions should include installation information to ensure that when a wireless control system is in use it should not interfere with, or be interfered by, other systems in use at that location.

Annex G (normative)

Design requirements for rail tracks, monorail tracks and support systems

G.1 Scope

The requirements below provide design rules for rail tracks (including supports) on which a suspension rig may traverse and monorail tracks for suspended platforms. The design rules given in this annex mainly apply to steel structures with material thicknesses $t \geq 3$ mm.

G.2 Characteristic loads and forces for rail tracks and rail track support systems

G.2.1 The vertical and horizontal characteristic wheel loads shall be determined using Table 9 for BMU suspension rig and Table 10 for TSP suspension rig.

G.2.2 Dynamic actions of the suspension rig may be considered as quasi-static.

G.3 Basis for structural analysis

G.3.1 The calculation model and basic assumptions for determining internal forces and moments shall represent the expected structural response under the load cases considered.

G.3.2 Linear elastic global analysis shall be used and the effect of displacements and deformations may be neglected.

G.3.3 The limit state method (partial safety method) shall be used for design checks.

G.3.4 The track may be modelled as single span or continuous over two or more spans.

G.3.5 The following internal forces and moments due to the BMU's wheel loads shall be taken into account in the design of the rail cross-section:

- a) biaxial bending due to vertical actions and transverse horizontal actions;
- b) vertical shear due to vertical actions; horizontal shear forces due to transverse horizontal actions may be neglected.

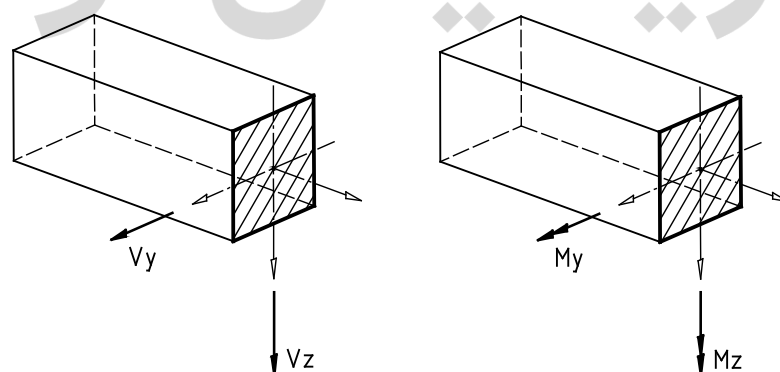

Figure G.1 — Cross-section forces

G.3.6 The type of cross-section used for a track shall be suitable for the characteristics of the supported BMU and the magnitude of the actions to be resisted. One of the following types of cross-section may be used:

- a) plain rolled I or H section (IPE/INP or equivalent – see Figure G.2a));
- b) column section (HEA/B – see Figure G.2b));
- c) circular hollow section (CHS – see Figure G.2c));
- d) lipped channel (only monorail tracks – see Figure G.2d)).

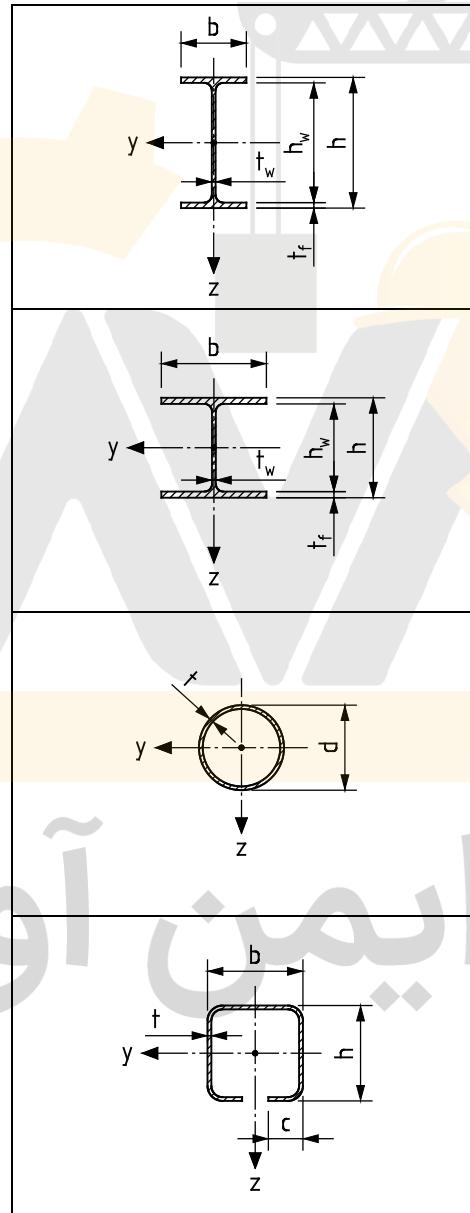

Figure G.2 — Types of cross-sections

G.3.7 The elastic resistance of cross-sections shall be taken as the design resistance.

G.3.8 The forces and moments applied to connections shall be determined from the global analysis.

G.3.9 The supporting system of the track shall be designed to resist the vertical forces and transverse and longitudinal horizontal forces due to the BMU's wheel loads.

G.4 Materials

G.4.1 The nominal values of the yield strength f_y and the ultimate strength f_u for structural steel should be obtained by using the values given in EN 1993 (all parts) (*Eurocode 3*).

G.4.2 The nominal values of the 0,2 % proof strength f_0 and the tensile strength f_u for aluminium shall be obtained by using the values given in EN 1999 (all parts) (*Eurocode 9*).

G.4.3 For structural analysis and design, the nominal values of dimensions should be used.

G.4.4 The nominal values of the yield strength f_{yb} and the ultimate strength f_{ub} for fasteners shall be obtained by using the values given in the relevant parts of EN 1993.

G.5 Ultimate limit states

G.5.1 General

The design of the rail track should be checked for resistance of cross-sections and local effects. Additionally, resistance of members should be checked for plain rolled I or H sections.

Required design checks:

- The yield criterion at any critical point of the cross-section may not be exceeded (G.5.3).
- The resistance of the member against lateral torsional buckling shall be satisfied (G.5.4.1).
- The end-supports shall be structurally equivalent to fork bearings (G.5.4.2).
- The web of I or H sections shall resist local effects due to wheel loads (G.5.4.3).
- The web of I or H sections at end- and intermediate-supports shall resist the effect of support reactions (G.5.4.4).
- The wheel/rail contact shall fulfil the requirements mentioned in G.6.

Bottom flanges charged with wheel loads shall be checked for local bending stresses combined with stresses due to bending of the member (G.5.5).

G.5.2 Recommended values for partial safety factors (γ_f)

Recommended values for partial safety factors (γ_f) for the ultimate limit state (ULS) are given in Table G.1 and Table G.2. These factors are derived from the values of v_E given in Table 2 and Table 3.

Table G.1 — Recommended values of γ_f (carbon steel and stainless steel)

Load case	Partial safety factor γ_f
1	1,5
2a and 2b	1,33
3	1,1

Table G.2 — Recommended values of γ_f (aluminium)

Load case	Partial safety factor γ_f	
	criterion	
	0,2 % proof strength f_0	tensile strength f_u
1	1,65	2,2
2a and 2b	1,46	2,0
3	1,15	1,5

G.5.3 Resistance of cross-sections of steel structures

$\sigma_{x,Ed}$ is the design value of the local longitudinal stress at the point of consideration (poc).

τ_{Ed} is the design value of the local shear stress at the point of consideration (poc).

Plain rolled I or H section:

$$\sigma_{x,Ed} = \frac{M_{y,Ed} \times z}{I_y} + \frac{M_{z,Ed} \times y}{I_z}$$

$$\sigma_{x,Ed} = \frac{M_{y,Ed} \cdot z}{I_y} + \frac{M_{z,Ed} \cdot y}{I_z}$$

where

$M_{y,Ed}$ is design bending moment, y-y axis;

$M_{z,Ed}$ is design bending moment, z-z axis;

Z is distance along z between neutral axis and poc;

Y is distance along y between neutral axis and poc;

I_y is second moment of area, y-y axis;

I_z is second moment of area, z-z axis.

$$\tau_{Ed} = \frac{V_{z,Ed} \cdot S_y}{t_w \cdot I_y} \quad \text{or} \quad \tau_{Ed} = \frac{V_{z,Ed}}{t_w \cdot h_w} \quad \text{if} \quad \frac{b \cdot t_f}{t_w \cdot h_w} \geq 0.6$$

where

$V_{z,Ed}$ is design shear force in z-direction;

S_y is first moment of area, y-y axis;

h is depth of the cross section;

b is width of the cross section;

- t_w is web thickness;
- t_f is flange thickness;
- h_w is depth of the web = $h - 2 \cdot t_f$.

Thin walled circular hollow section (r_m is the mean radius):

$$\sigma_{x,Ed} = \frac{M_{y,Ed} \cdot z + M_{z,Ed} \cdot r_m \cdot \sqrt{1 - \left(\frac{z}{r_m}\right)^2}}{I}$$

$$\tau_{Ed} = \frac{2 \cdot V_{z,Ed}}{A} \cdot \sqrt{1 - \left(\frac{z}{r_m}\right)^2}, \text{ maximum value for } \tau_{Ed} \text{ at } z = 0: \tau_{Ed} = \frac{2 \cdot V_{z,Ed}}{A}$$

where

A is area of the cross section.

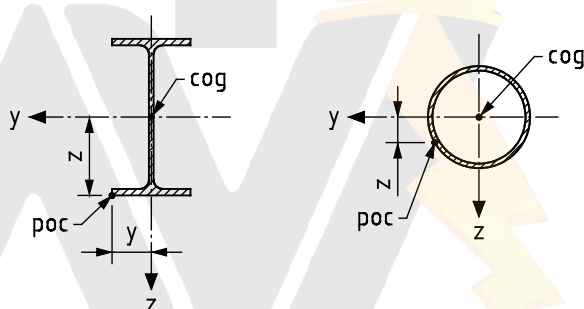

Figure G.3 — Examples of points of consideration

For the elastic verification the following yield criterion for a critical point of the cross section may be used:

$$\left(\frac{\sigma_{x,Ed}}{f_y}\right)^2 + 3 \cdot \left(\frac{\tau_{Ed}}{f_y}\right)^2 \leq 1$$

G.5.4 Resistance of bisymmetrical members of steel structures

G.5.4.1 A laterally unrestrained beam subject to major axis bending shall be verified against lateral torsional buckling as follows.

The design value of the maximum bending moment about the major axis $M_{y,Ed}$ due to the BMU's vertical actions only in the span of the beam considered shall satisfy:

$$\frac{M_{y,Ed}}{M_{b,Rd}} \leq 1$$

$M_{b,Rd}$ is the design buckling resistance moment.

$$\bar{\lambda}_{LT} = \sqrt{\frac{f_y \cdot W_{y,el}}{M_{cr}}}$$

where

$W_{y,el}$ is elastic section modulus, y-y axis.

M_{cr} is the elastic critical moment for lateral-torsional buckling. Guidance on determining M_{cr} for simply supported members is given in G.9.1.

$$\Phi_{LT} = 0,5 \cdot \left[1 + 0,34 \cdot (\bar{\lambda}_{LT} - 0,4) + 0,75 \cdot \bar{\lambda}_{LT}^2 \right] \text{ for IPE80-300, HEA/B100-600, HEM100-550}$$

$$\Phi_{LT} = 0,5 \cdot \left[1 + 0,49 \cdot (\bar{\lambda}_{LT} - 0,4) + 0,75 \cdot \bar{\lambda}_{LT}^2 \right] \text{ for INP and IPE/HE not mentioned above}$$

$$\chi_{LT} = \frac{1}{f \cdot \left(\Phi_{LT} + \sqrt{\Phi_{LT}^2 - 0,75 \cdot \bar{\lambda}_{LT}^2} \right)} \text{ but } \chi_{LT} \leq 1$$









The value of f may be taken as 1 (conservative value) or may be calculated as follows:

$$f = 1 - 0,5 \cdot (1 - k_c) \cdot \left[1 - 2 \cdot (\bar{\lambda}_{LT} - 0,8)^2 \right] \text{ but } f \leq 1$$

k_c is a correction factor in accordance with Table G.6.

Design buckling resistance moment: $M_{b,Rd} = \chi_{LT} \cdot f_y \cdot W_{y,el}$

Table G.3 — Correction factors k_c

Moment distribution	k_c
 $\psi = 1$	1,0
 $1 \leq \psi \leq 1$	$\frac{1}{1,33 - 0,33\psi}$
	0,94
	0,90
	0,91
	0,86
	0,77
	0,82

G.5.4.2 The maximum support reaction $R_{z,Ed}$ corresponding to the value of $M_{y,Ed}$ as expressed in section G.5.1.2 shall satisfy the following condition:

$$\frac{R_{z,Ed}}{\chi_x \cdot N_{w,Rd}} \leq 1$$

where

$N_{w,Rd}$ is design resistance of the web above the support: $N_{w,Rd} = f_y \cdot b_{eff} \cdot t_w$;

χ_x is reduction factor for buckling of the web about the x-x axis depending on the relative slenderness $\bar{\lambda}_x$.

$$\bar{\lambda}_x = \sqrt{\frac{N_{w,Rd}}{N_{cr,x}}}$$

$$\Phi = 0.5 \cdot \left[1 + 0,49 \cdot (\bar{\lambda}_x - 0,2) + \bar{\lambda}_x^2 \right]$$

$$\chi_x = \frac{1}{\Phi + \sqrt{\Phi^2 - \bar{\lambda}_x^2}}$$

b_{eff} = effective width of the web above the support according to G.5.4.4 c)

t_w = web thickness

$N_{cr,x}$ = elastic critical force of the web above the support: $N_{cr,x} = \frac{\pi^2 \cdot E \cdot b_{eff} \cdot t_w^3}{48 \cdot h^2}$

h = depth of the cross section

The elastic stability limit $N_{cr,x}$ represents a fixed column with a free end with cross section $b_{eff} \cdot t_w$.

G.5.4.3 Local effects due to vertical wheel loads for BMUs supported on top of beams. The resistance of the beams shall be checked for the effects of the local stress induced by the BMU vertical wheel load. The web of the I or H-section shall be checked for the following effects of vertical wheel loads: local compressive stresses that lead to crushing, crippling or buckling of the web.

a) Crushing:

Longitudinal and global shear stress at the horizontal web section considered:

$$\sigma_{x,Ed} = \frac{M_{y,Ed} \cdot z}{I_y} \quad \text{resp.} \quad \tau_{Ed} = \frac{V_{z,Ed} \cdot S_y}{t_w \cdot I_y} \quad \text{or} \quad \tau_{Ed} = \frac{V_{z,Ed}}{t_w \cdot h_w} \quad \text{if} \quad \frac{b \cdot t_f}{t_w \cdot h_w} \geq 0,6$$

The vertical stress $\sigma_{z,Ed}$ in the web of an I or H section due to wheel load $F_{z,Ed}$ on the top flange shall be determined from:

$$\sigma_{z,Ed} = -\frac{F_{z,Ed}}{2 \cdot t_w \cdot d}$$

where

d is the distance below the top of the flange to the horizontal web section considered.

The local shear stress $\tau_{l,Ed}$ due to wheel loads on the top of the flange of an I or H-section shall be taken as additional to the global shear stress τ_{Ed} due to the same wheel load. The additional shear stress $\tau_{l,Ed}$ may be neglected at levels in the web below a distance of $0.2 \times h_w$ from the underside of the top flange. The maximum value of the local shear stress $\tau_{l,Ed}$ due to a wheel load, acting at each side of the wheel load position, may be assumed to be equal to 20 % of the maximum vertical stress $\sigma_{z,Ed}$ at that level in the web.

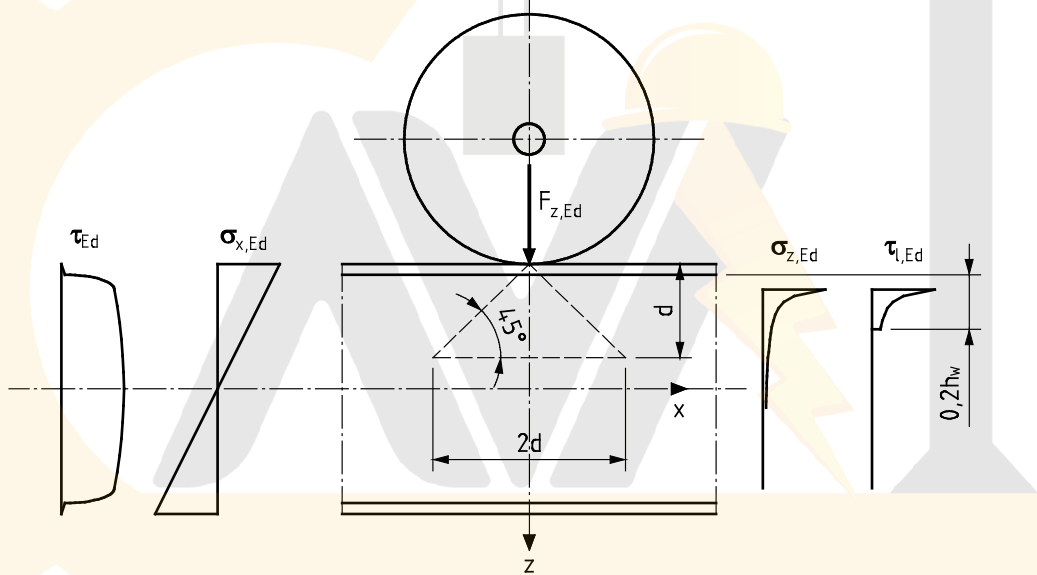

Figure G.4 — Local stresses due to wheel loads

For the elastic verification the following yield criterion for the horizontal web section considered may be used:

$$\left(\frac{\sigma_{x,Ed}}{f_y}\right)^2 + \left(\frac{\sigma_{z,Ed}}{f_y}\right)^2 - \left(\frac{\sigma_{x,Ed}}{f_y}\right) \cdot \left(\frac{\sigma_{z,Ed}}{f_y}\right) + 3 \cdot \left(\frac{\tau_{Ed} + \tau_{l,Ed}}{f_y}\right)^2 \leq 1$$

b) Crippling:

For wheel loads at a distance less than 1,5 times the depth of the cross section from the end of the beam:

$$F_{z,Rd} = 0,125 \cdot t_w^2 \cdot \sqrt{E \cdot f_y} \cdot \sqrt{\frac{t_f}{t_w}}$$

For wheel loads at a distance not less than 1,5 times the depth of the cross section from the end of the beam:

$$F_{z,Rd} = 0,5 \cdot t_w^2 \cdot \sqrt{E \cdot f_y} \cdot \sqrt{\frac{t_f}{t_w}}$$

The design value of the wheel load $F_{z,Ed}$ shall satisfy:

$$\frac{F_{z,Ed}}{F_{z,Rd}} \leq 1$$

c) Buckling of the web:

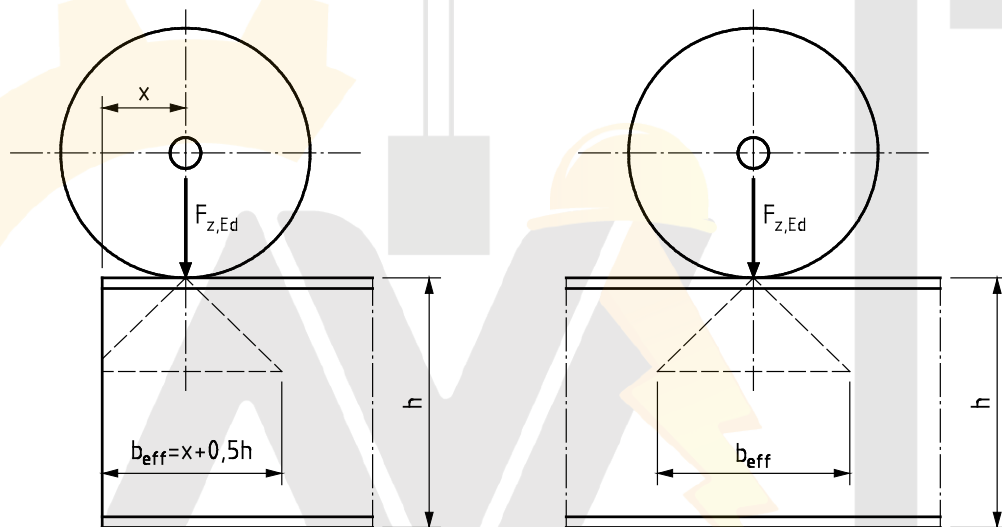

Figure G.5 — Effective width below wheel

$$N_{c,Rd} = f_y \cdot b_{eff} \cdot t_w$$

$$\bar{\lambda} = \sqrt{\frac{N_{c,Rd}}{N_{cr}}}$$

N_{cr} = elastic critical force of the web below the wheel:
$$N_{cr} = \frac{\pi^2 \cdot E \cdot b_{eff} \cdot t_w^3}{12 \cdot h^2}$$

The elastic stability limit $N_{cr,x}$ represents a column with cross section $b_{eff} \cdot t_w$ and $L_{cr} = h$

$$\Phi = 0,5 \cdot \left[1 + 0,49 \cdot (\bar{\lambda} - 0,2) + \bar{\lambda}^2 \right]$$

$$\chi = \frac{1}{\Phi + \sqrt{\Phi^2 - \bar{\lambda}^2}}$$

The design value of the wheel load $F_{z,Ed}$ shall satisfy:

$$\frac{F_{z,Ed}}{\chi \cdot N_{c,Rd}} \leq 1$$

G.5.4.4 Local effects due to support reactions for BMUs supported on the top of beams. The web of the beam above the supports shall be checked for the following effects of vertical support reaction: local compressive stresses that lead to crushing, crippling or buckling of the web.

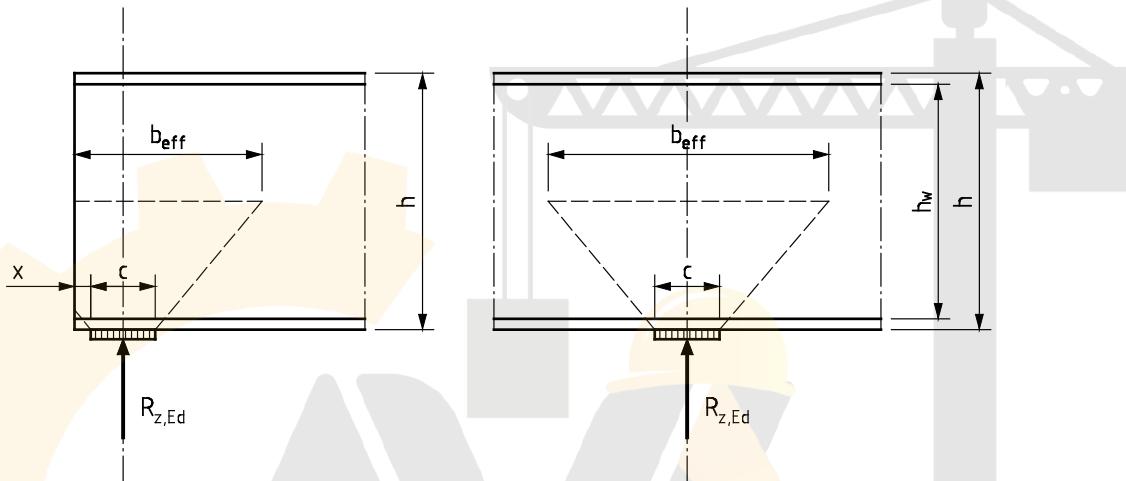

Figure G.6 — Effective width above supports

a) Crushing:

Intermediate support:

$$b_{eff} = c + 2 \cdot t_f \cdot \sqrt{\frac{b_f}{t_w}} \cdot \sqrt{1 - \left(\frac{\sigma_{f,Ed}}{f_y} \right)^2}$$

where

- c is length of the support;
- b_f is width of the flange ($b_f \leq 25 \cdot t_f$);
- t_f is flange thickness;
- $\sigma_{f,Ed}$ is the stress at the midline of the flange due to the overall internal moment in the beam.

End support:

$$b_{eff} = x + c + t_f \cdot \sqrt{\frac{b_f}{t_w}}$$

The stress at the midline of the flange $\sigma_{f,Ed}$ due to the overall internal moment is assumed to be zero at end supports.

where c is the length of the support and b_f is the width of the flange ($b_f \leq 25 \times t_f$).

Resistance of the web:

$$F_{z,Rd} = f_y \cdot b_{eff} \cdot t_w$$

The design value of the support reaction $R_{z,Ed}$ shall satisfy:

$$\frac{R_{z,Ed}}{F_{z,Rd}} \leq 1$$

b) Crippling:

End support:

$$F_{z,Rd} = 0,125 \cdot t_w^2 \cdot \sqrt{E \cdot f_y} \cdot \left[\sqrt{\frac{t_f}{t_w}} + 3 \cdot \left(\frac{t_w}{t_f} \right) \cdot \left(\frac{c}{h_w} \right) \right]$$

Intermediate support:

$$F_{z,Rd} = 0,5 \cdot t_w^2 \cdot \sqrt{E \cdot f_y} \cdot \left[\sqrt{\frac{t_f}{t_w}} + 3 \cdot \left(\frac{t_w}{t_f} \right) \cdot \left(\frac{c}{h_w} \right) \right]$$

The value of $\frac{c}{h_w}$ should not be taken greater than 0,2.

The design value of the support reaction $R_{z,Ed}$ shall satisfy:

$$\frac{R_{z,Ed}}{F_{z,Rd}} \leq 1$$

c) Buckling of the web:

End support:

$$b_{eff} = x + \frac{1}{2} \cdot (c + \sqrt{h^2 + c^2}) \text{ but } b_{eff} \leq \sqrt{h^2 + c^2}$$

Intermediate support:

$$b_{eff} = \sqrt{h^2 + c^2}$$

$$N_{c,Rd} = f_y \cdot b_{eff} \cdot t_w$$

$$\bar{\lambda} = \sqrt{\frac{N_{c,Rd}}{N_{cr}}}$$

N_{cr} = elastic critical force of the web below the wheel: $N_{cr} = \frac{\pi^2 \cdot E \cdot b_{eff} \cdot t_w^3}{12 \cdot h^2}$

$$\Phi = 0,5 \cdot \left[1 + 0,49 \cdot (\bar{\lambda} - 0,2) + \bar{\lambda}^2 \right]$$

$$\chi = \frac{1}{\Phi + \sqrt{\Phi^2 - \bar{\lambda}^2}}$$

The design value of the wheel load $F_{z,Ed}$ shall satisfy:

$$\frac{F_{z,Ed}}{\chi \cdot N_{c,Rd}} \leq 1$$

G.5.5 Resistance of bottom flanges of I or H steel sections to wheel loads

G.5.5.1 Ultimate limit state

The plastic design resistance of the bottom flange of a beam to a wheel load $F_{z,Ed}$ shall be determined from

$$\frac{F_{z,Ed}}{F_{f,Rd}} \leq 1$$

$$F_{f,Rd} = \frac{l_{eff} \cdot t_f^2 \cdot f_y}{4 \cdot m} \cdot \left[1 - \left(\frac{\sigma_{f,Ed}}{f_y} \right)^2 \right]$$

where

$\sigma_{f,Ed}$ is the stress at the midline of the flange due to the overall internal moment in the beam.

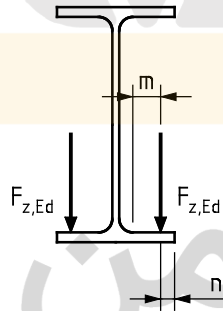

Figure G.7 — Wheel loads on bottom flange

The lever arm m for a rolled section shall be determined as follows:

$$m = 0,5 \cdot (b - t_w) - 0,8 \cdot r - n$$

Where n is the distance from the centreline of the wheel load to the edge of the flange and r is the root radius.

Effective length of the flange resisting the wheel load:

Wheel adjacent to a non-reinforced simple joint:

$$l_{eff} = 2 \cdot (m + n)$$

Wheel remote from the end of a member (x_w is wheel spacing):

$$l_{eff} = 4\sqrt{2} \cdot (m + n) \quad \text{if} \quad x_w \geq 4\sqrt{2} \cdot (m + n)$$

$$l_{eff} = 2\sqrt{2} \cdot (m + n) + 0.5 \cdot x_w \quad \text{if} \quad x_w < 4\sqrt{2} \cdot (m + n)$$

G.5.5.2 Serviceability limit state

A stress check shall be carried out for the bottom flange loaded by characteristic wheel loads. The following method may be used to determine the local bending stresses in the bottom flange of an I or H section beam due to wheel loads applied to the bottom flange.

The bending stresses due to wheel loads applied at locations more than b from the end of the beam, where b is the flange width, can be determined at three locations indicated in Figure G.8.

- location 0: the web-to-flange transition
- location 1: centreline of the wheel load
- location 2: outside edge of the flange

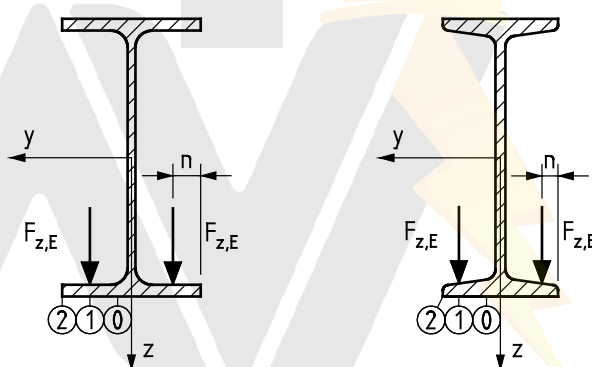

Figure G.8 — Locations for determining stresses due to wheel loads

Provided that the distance x_w along the runway beam between adjacent wheel loads is not less than $1,5 b$ where b is the flange width of the beam, the local longitudinal bending stress $\sigma_{ox,E}$ and transverse bending stress $\sigma_{oy,E}$ in the bottom flange due to the application of a wheel load more than b from the end of the beam shall be obtained from:

$$\sigma_{ox,E} = c_x \cdot \frac{F_{z,E}}{t_1^2}$$

$$\sigma_{oy,E} = c_y \cdot \frac{F_{z,E}}{t_1^2}$$

where

$F_{z,E}$ is the vertical characteristic wheel load;

t_1 is the thickness of the flange at the centreline of the wheel load.

The coefficients c_x and c_y for determining the longitudinal and transverse bending stresses at the three locations 0, 1 and 2 shown in Figure G.8 can be determined from Table G.4 depending on whether the beam has parallel flanges or taper flanges, and the value of the ratio μ given by:

$$\mu = \frac{2 \cdot n}{b - t_w}$$

where

- n is distance from the centreline of the wheel load to the free edge of the flange;
 t_w is web thickness.

Table G.4 — Coefficients c_{xi} and c_{yi} for calculating stresses at points 0, 1 and 2

Stress	Parallel flange beams	Taper flange beams
Longitudinal bending stress $\sigma_{ox,E}$	$c_{x0} = 0,050 - 0,580\mu + 0,148e^{3,015\mu}$	$c_{x0} = -0,981 - 1,479\mu + 1,120e^{1,322\mu}$
	$c_{x1} = 2,230 - 1,490\mu + 1,390e^{-18,33\mu}$	$c_{x1} = 1,810 - 1,150\mu + 1,060e^{-7,700\mu}$
	$c_{x2} = 0,730 - 1,580\mu + 2,910e^{-6,000\mu}$	$c_{x2} = 1,990 - 2,810\mu + 0,840e^{-4,690\mu}$
Transverse bending stress $\sigma_{oy,E}$	$c_{y0} = 2,110 + 1,977\mu + 0,0076e^{6,530\mu}$	$c_{y0} = -1,096 + 1,095\mu + 0,192e^{-6,000\mu}$
	$c_{y1} = 10,108 - 7,408\mu - 10,108e^{-1,364\mu}$	$c_{y1} = 3,965 - 4,835\mu - 3,965e^{-2,675\mu}$
	$c_{y2} = 0,0$	$c_{y2} = 0,0$
Sign convention: $c_{x,i}$ and $c_{y,i}$ are positive for tensile stresses at the bottom face of the flange.		
The coefficients for taper flange beams are for a slope of 14 % or 8°. They are conservative for beams with a larger flange slope. For beams with a smaller flange slope, it is conservative to adopt the coefficients for parallel flange beams. Alternatively, linear interpolation may be used.		

Alternatively, in case of wheel loads applied near the outside edges of the flange, the values of the coefficients c_x and c_y given in Table G.5 may be used.

Table G.5 — Coefficients for calculating stresses near the outside edges of flanges

Stress	Coefficient	Parallel flange beams		Taper flange beams
		$\mu = 0,10$	$\mu = 0,15$	$\mu = 0,15$
Longitudinal bending stress $\sigma_{ox,E}$	c_{x0}	0,2	0,2	0,2
	c_{x1}	2,3	2,1	2,0
	c_{x2}	2,2	1,7	2,0
Transverse bending stress $\sigma_{oy,E}$	c_{y0}	-1,9	-1,8	-0,9
	c_{y1}	0,6	0,6	0,6
	c_{y2}	0,0	0,0	0,0
Sign convention: $c_{x,i}$ and $c_{y,i}$ are positive for tensile stresses at the bottom face of the flange.				
The coefficients for taper flange beams are for a slope of 14 % or 8°. They are conservative for beams with a larger flange slope. For beams with a smaller flange slope, it is conservative to adopt the coefficients for parallel flange beams. Alternatively, linear interpolation may be used.				

For the elastic verification the local bending stresses may be reduced with a factor of $\varepsilon = 0,75$ according to FEM 9.341.

The reduced local stresses working in the same direction to the stresses due to global bending shall be added, taking the sign convention into account:

$$\sigma_{x,sum,E} = \sigma_{x,E} + \varepsilon \cdot \sigma_{ox,E}$$

The yield criteria for points 0, 1 and 2 shall be satisfied for both sides of the bottom flange:

$$\left(\frac{\sigma_{x,sum,E}}{f_y} \right)^2 + \left(\frac{\varepsilon \cdot \sigma_{oy,E}}{f_y} \right)^2 - \frac{\sigma_{x,sum,E} \cdot \varepsilon \cdot \sigma_{oy,E}}{f_y^2} \leq 1$$

G.6 Wheel/rail contact

G.6.1 General

The dimensions of the wheel shall satisfy the requirements for the wheel/rail contact according to FEM 1.001, booklet 4.

The check is carried out with the mean characteristic wheel load $F_{m,E}$ calculated with the following expression:

$$F_{m,E} = \frac{F_{z,min,E} + 2 \cdot F_{z,max,E}}{3}$$

where

$F_{z,min,E}$ is the minimum characteristic load for the wheel under consideration;

$F_{z,max,E}$ is the maximum characteristic load for the wheel under consideration.

Stribeck stress:
$$p_{S,E} = \frac{F_{m,E}}{b \cdot D_w}$$

where

b is load bearing width (see Figure G.9);

D_w is wheel diameter.

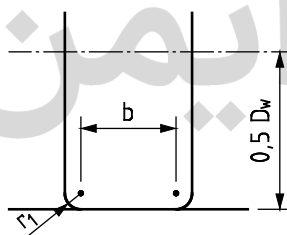

Figure G.9 — Load bearing width

G.6.2 Condition for load case 1

$$\frac{P_{S,E}}{P_{1,R}} \leq 1$$

$$P_{1,R} = f_S \cdot c_1 \cdot c_2$$

where

f_S is allowable Stribeck stress according to Table G.6;

c_1 is factor depending on the speed of the wheel;

c_2 is factor depending on the type of SAE (see Table 4 and Table 6).

Table G.6 — Values of f_S

Ultimate strength of the steel grade of the wheel	f_S
	N/mm ²
$f_u > 500$ N/mm ²	5.0
$f_u > 600$ N/mm ²	5.6
$f_u > 700$ N/mm ²	6.5
$f_u > 800$ N/mm ²	7.2

$$c_1 = \frac{1}{0,803 + 0,0169 \cdot n^{0.7}}$$

where

$$n = \frac{v}{\pi \cdot D_w}$$

where

v is travel speed of the SAE [m/min];

D_w is wheel diameter [m].

G.6.3 Condition for load case 2a, 2b and 3

$$\frac{P_{S,E}}{P_{2,R}} \leq 1$$

$$P_{2,R} = f_S \cdot c_{1,max} \cdot c_{2,max}$$

where

f_S is allowable Stribeck stress according to Table G.6.

G.7 Rail track support system

G.7.1 The rail track support system may be braced or unbraced in one or two directions or in a combination of both.

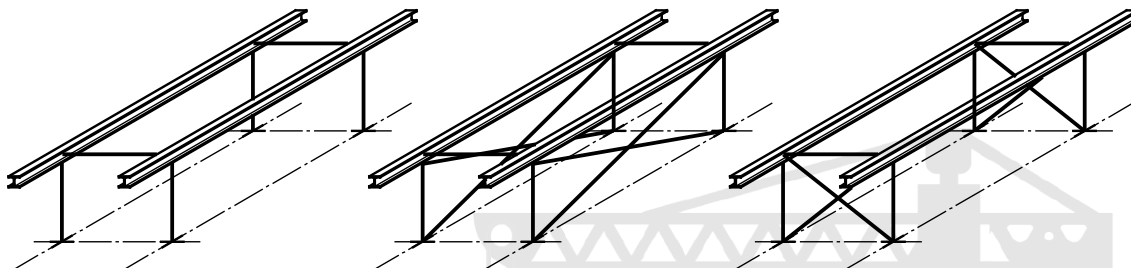

Figure G.10 — Examples of support systems

G.7.2 The bracing system shall be designed to resist the effect of the BMU's horizontal wheel loads. In-service wind loads on the support system may be neglected.

G.7.3 Stanchions in fully braced support systems shall be designed to resist the effect of the BMU's vertical actions only.

The design value of the compressive force $N_{c,Ed}$ shall satisfy:

$$\frac{N_{c,Ed}}{N_{b,Rd}} \leq 1$$

$N_{b,Rd}$ is the design buckling resistance.

$$N_{b,Rd} = \chi \cdot f_y \cdot A$$

where

$$\chi = \frac{1}{\Phi + \sqrt{\Phi^2 - \bar{\lambda}^2}} \text{ but } \chi \leq 1$$

$$\Phi = 0,5 \cdot \left[1 + \alpha \cdot (\bar{\lambda} - 0,2) + \bar{\lambda}^2 \right]$$

$$\bar{\lambda} = \sqrt{\frac{f_y \cdot A}{N_{cr}}} \text{ where } A \text{ is the cross sectional area of the stanchion.}$$

N_{cr} is the elastic critical force for the relevant buckling mode. Guidance on determining N_{cr} for simply supported members is given in G.9.2.

The imperfection factor α corresponds to the appropriate buckling curve and shall be taken from Table G.8. The appropriate buckling curve shall be determined according to Table G.9.

Table G.7 — Imperfection factors for buckling curves

Buckling curve	a	b	c	d
Imperfection factor	0,21	0,34	0,49	0,76

Table G.8 — Selection of buckling curves for a cross section

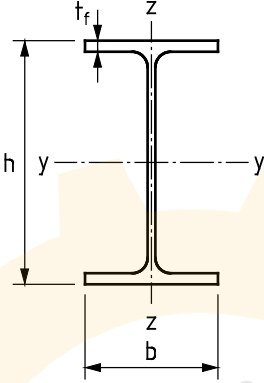
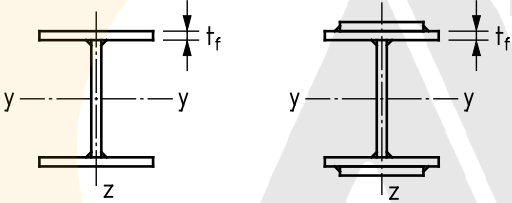
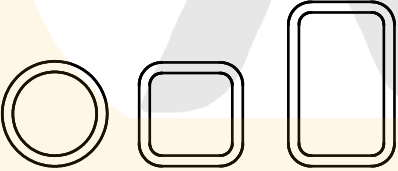
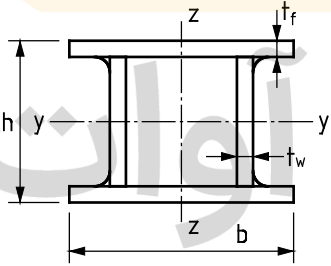
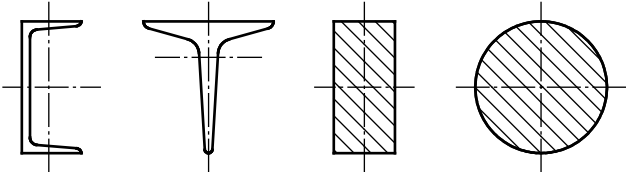
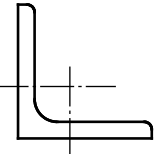
Cross section	Limits	Buckling about axis	Buckling curve	
			S 235 S 275 S 355 S 420	S 460
Rolled sections 	$h/b > 1,2$	$t_f \leq 40$ mm y-y z-z	a	a_0
			40 mm $< t_f \leq 100$ y-y z-z	b
	$h/b \leq 1,2$	$t_f \leq 100$ mm y-y z-z	b	a
			$t_f > 100$ mm y-y z-z	d
Welded I-sections 	$t_f \leq 40$ mm	y-y z-z	b	b
	$t_f > 40$ mm	y-y z-z	c	c
Hollow sections 	hot finished	any	a	a_0
	cold formed	any	c	c
Welded box sections 	generally (except as below)	any	b	b
	thick welds: $a > 0,5 t_f$ $b/t_f < 30$ $h/t_w < 30$	any	c	c
U-, T- and solid sections 		any	c	c
L-sections 		any	b	b

G.7.4 Stanchions in unbraced support systems shall be designed to resist the effect of the BMU's vertical actions and transverse horizontal actions.

Stanchions which are subjected to combined action of uniaxial bending and axial compression shall satisfy:

$$1,1 \cdot \frac{N_{c,Ed}}{N_{b,Rd}} + 1,1 \cdot \frac{M_{y,Ed}}{M_{b,Rd}} \leq 1 \quad \text{or} \quad 1,1 \cdot \frac{N_{c,Ed}}{N_{b,Rd}} + 1,1 \cdot \frac{M_{z,Ed}}{f_y \cdot W_{z,el}} \leq 1$$

$N_{b,Rd}$ in accordance with G.7.3. and $M_{b,Rd}$ in accordance with G.5.1.2.

G.8 Serviceability limit states

G.8.1 For serviceability limit states (SLS) the partial factors for actions shall be taken as 1.0.

G.8.2 The recommended limits for vertical and horizontal deflections given in Table G.10 may be applied. Lower or higher values may be substituted if necessary for structural or operational reasons by agreement between the client, the designer and the BMU supplier.

Table G.9 — Recommended values of deflection

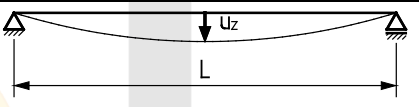
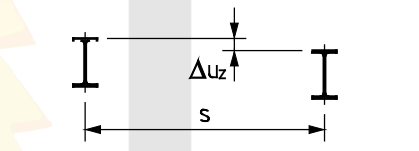
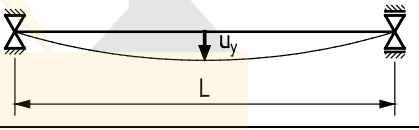
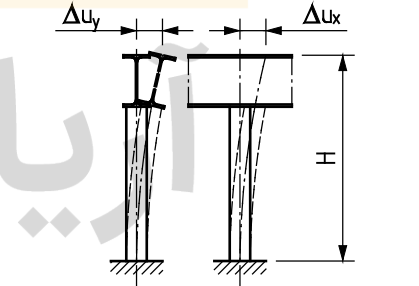
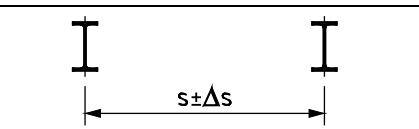
Description of the deflection	Recommended value	
vertical deflection u_z over the span L between the rail supports	$u_z \leq L / 200$ and $u_z \leq 30$ mm	
differential vertical deflection Δu_z of two beams spaced s forming a rail track	$\Delta u_z \leq s / 200$	
horizontal deflection u_y over the span L measured at the top of the beam	$\Delta u_y \leq L / 200$ and $u_y \leq 30$ mm	
horizontal displacement u_x or u_y of a rail support at rail level H where H is the height to the level at which the BMU is supported	$\Delta u_x \leq H / 400$ $\Delta u_y \leq H / 400$	
change of spacing Δs between the centres of beams including the effect of thermal change	$\Delta s \leq 10$ mm	

G.9 Elastic critical moments and forces for plain rolled I and H sections

G.9.1 Elastic critical moment for lateral torsion buckling of members in bending

G.9.1.1 General

The end conditions of the members have to satisfy the requirements of fork bearings as illustrated in Figure G.11.

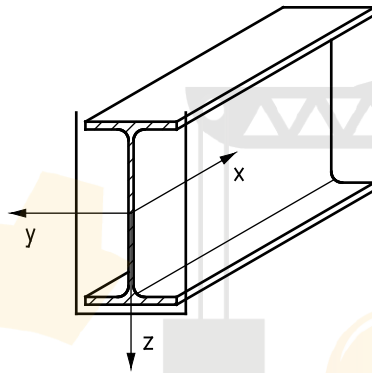

Figure G.11 — Fork bearing

An end condition may be considered as fork bearing if:

rotation about member axis: $\phi_x = 0$

lateral displacement: $dy = 0$

vertical displacement: $dz = 0$

G.9.1.2 Uniform bending

The critical moment M_{cr} for members in pure bending is given by the expression:

$$M_{cr} = \frac{\pi}{L} \cdot \sqrt{E \cdot I_z \cdot G \cdot I_T \cdot \left(1 + \frac{\pi^2 \cdot E \cdot I_w}{L^2 \cdot G \cdot I_T} \right)}$$

where

E is modulus of elasticity for steel in the elastic range = $2,1 \cdot 10^5$ N/mm²;

G is shear modulus for steel = $0,81 \cdot 10^5$ N/mm²;

L is member length;

I_z is second moment of area about the minor axis;

I_T is St. Venant torsional constant;

I_w is warping constant.

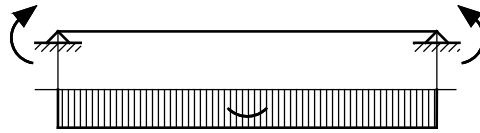

Figure G.12 — Pure bending

G.9.1.3 Non-uniform bending

$$M_{cr} = \frac{C}{L} \cdot \sqrt{E \cdot I_z \cdot G \cdot I_t}$$

where

$$C = \pi \cdot C_1 \cdot \left(\sqrt{1 + \left(\frac{\pi \cdot S}{L} \right)^2} \cdot (C_2^2 + 1) + \frac{\pi \cdot S}{L} \cdot C_2 \right)$$

$$S = \sqrt{\frac{E \cdot I_w}{G \cdot I_t}}$$

Or with I_w approximated as $I_w = \frac{1}{4} \cdot I_z \cdot h^2$: $S = \frac{h}{2} \cdot \sqrt{\frac{E \cdot I_z}{G \cdot I_t}}$ where h = depth of the cross section.

The coefficient C_1 depends on the type of loading i.e. the shape of the bending diagram.

The coefficient C_2 takes into account the location of the loading with respect to the section's neutral axis.

Flange in compression loaded: $C_2 < 0$

Flange in tension loaded: $C_2 > 0$

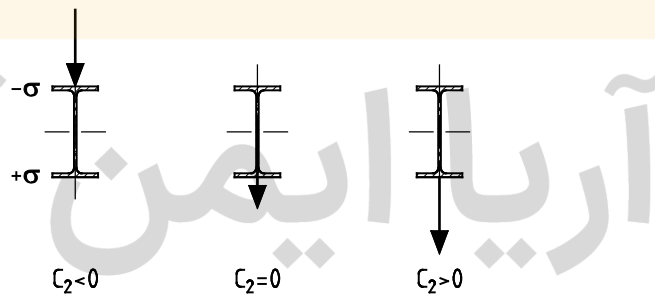
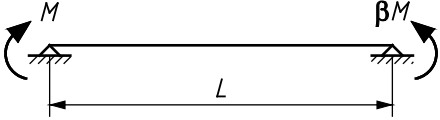
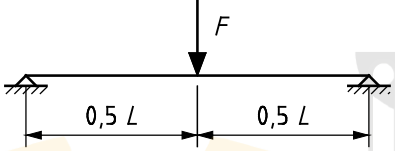
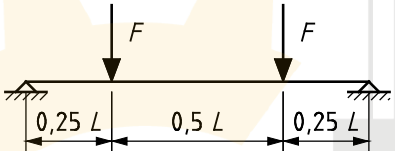
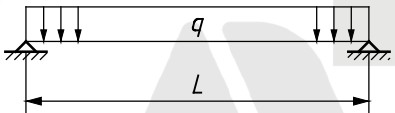

Figure G.13 — Sign of coefficient C_2

The values of C_1 and C_2 for selected loadings can be obtained from Table G.10.

Table G.10 — Coefficients C_1 and C_2

Case	Loading	C_1	C_2
1	 <p>M = end moment with the largest absolute value</p>	$1.75 - 1.05\beta + 0.3\beta^2$ $-1 \leq \beta \leq 1$ $C_1 \leq 2.3$	0
2		1,35	0,55
3		1,04	0,42
4		1,13	0,45

G.9.2 Elastic critical force for buckling of members in compression

The elastic critical force N_{cr} for selected buckling modes are given in Table G.11 where

$E = 2,1 \cdot 10^5 \text{ N/mm}^2$;

$I =$ second moment of area corresponding to the buckling mode;

$L =$ member length.

Table G.11 — Elastic critical force N_{cr}

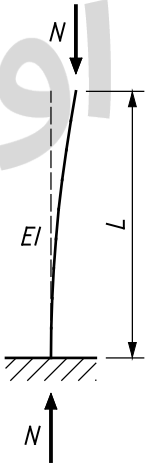
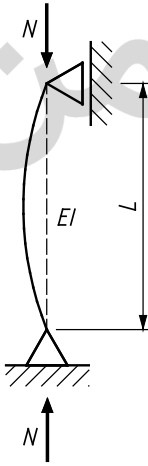
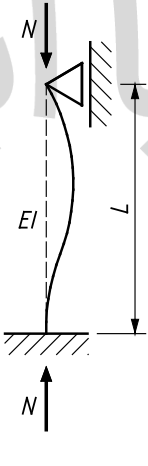
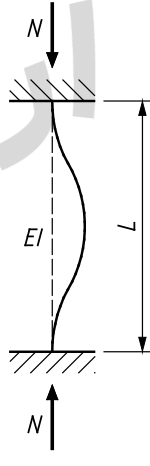
Buckling mode				
Elastic critical force	$N_{cr} = \frac{\pi^2 EI}{4L^2}$	$N_{cr} = \frac{\pi^2 EI}{L^2}$	$N_{cr} = \frac{2\pi^2 EI}{L^2}$	$N_{cr} = \frac{4\pi^2 EI}{L^2}$

G.10 References

EN 1993-1-1, *Eurocode 3: Design of steel structures – Part 1-1: General rules and rules for buildings*

NEN-EN 1993-1-1+C2/NB, *Eurocode 3: Design of steel structures – National Annex to EN 1993-1-1*

EN 1993-6, *Eurocode 3: Design of steel structures – Part 6: Crane supporting structures*

FEM 1.001, *Rules for the design of hoisting appliances, booklet 2: Classification and loading on structures and mechanisms*

FEM 1.001, *Rules for the design of hoisting appliances, booklet 4: Checking for fatigue and choice of mechanism components*

FEM 9.341, *Rules for the design of series lifting equipment: Local girder stresses*

Seeßelberg, Prof. Dr.-Ing. C., *Kranbahnen: Bemessung und konstruktive Gestaltung*, 3rd ed. 2009



آریا ایمن آوات

Annex ZA (informative)

Relationship between this European Standard and the Essential Requirements of EU Directive 2006/42/EC

This European Standard has been prepared under a mandate given to CEN by the European Commission and the European Free Trade Association to provide a means of conforming to Essential Requirements of the New Approach Directive Machinery 2006/42/EC.

Once this standard is cited in the Official Journal of the European Union under that Directive and has been implemented as a national standard in at least one Member State, compliance with the normative clauses of this standard confers, within the limits of the scope of this standard, a presumption of conformity with the relevant Essential Requirements of that Directive and associated EFTA regulations.

WARNING — Other requirements and other EU Directives may be applicable to the product(s) falling within the scope of this standard.



آريا ايمن آوات

Bibliography

- [1] FEM 9.511, *Rules for the design of series lifting equipment: Classification of mechanisms*
- [2] FEM 9.341, *Rules for the design of series lifting equipment: Local girder stresses*
- [3] FEM 1.001, *Rules for the design of hoisting appliances, booklet 2: Classification and loading on structures and mechanisms*
- [4] FEM 1.001, *Rules for the design of hoisting appliances, booklet 3: Calculating the stresses in structures*
- [5] FEM 1.001, *Rules for the design of hoisting appliances, booklet 4: Checking for fatigue and choice of mechanism components*
- [6] EN 12158-1:2000+A1:2010, *Builders' hoists for goods — Part 1: Hoists with accessible platforms*
- [7] EN 14492-1:2006+A1:2009, *Cranes — Power driven winches and hoists — Part 1: Power driven winches*
- [8] EN 60068-2-64, *Environmental testing — Part 2-64: Tests — Test Fh: Vibration, broadband random and guidance (IEC 60068-2-64)*

آریا ایمن آوات

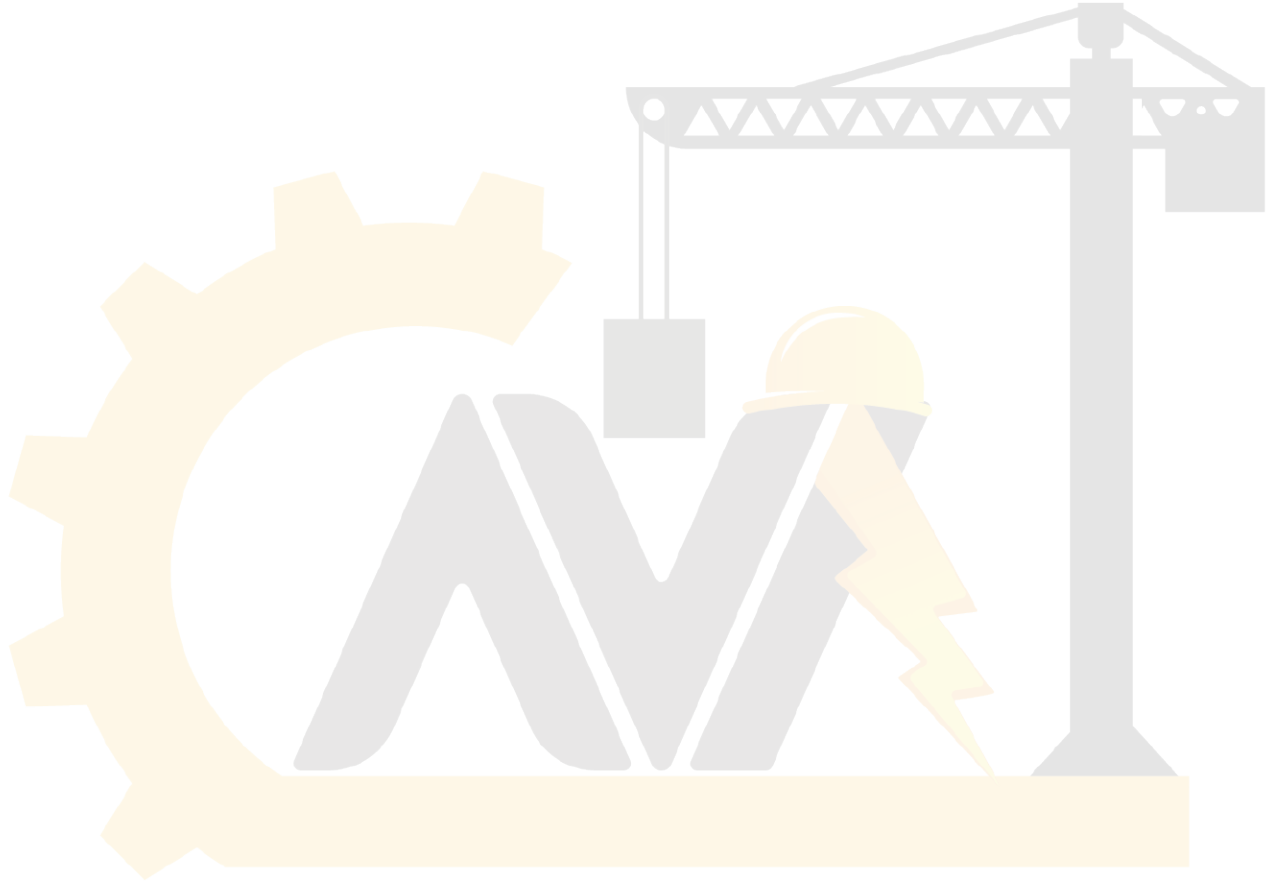

آریا ایمن آوات

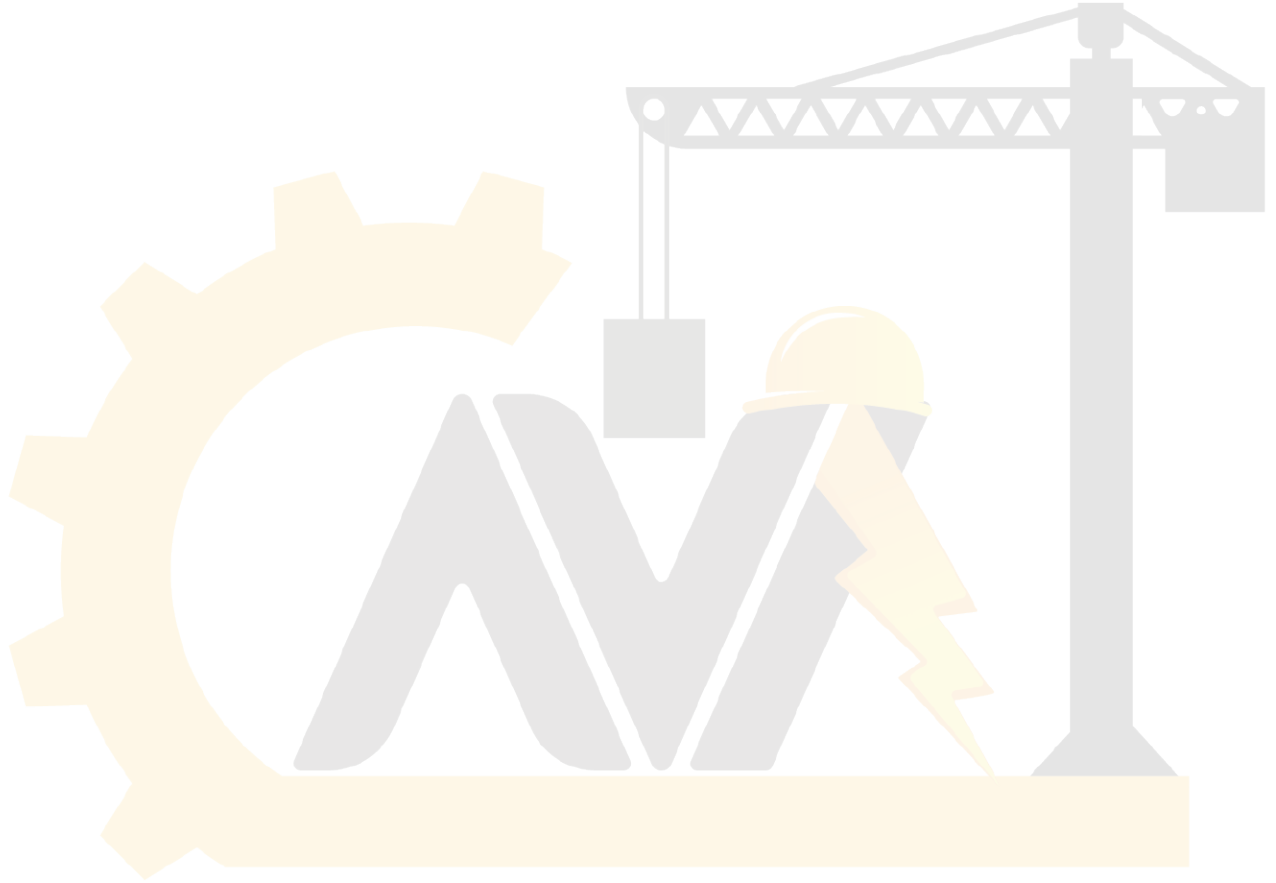

آریا ایمن آوات

British Standards Institution (BSI)

BSI is the national body responsible for preparing British Standards and other standards-related publications, information and services.

BSI is incorporated by Royal Charter. British Standards and other standardization products are published by BSI Standards Limited.

About us

We bring together business, industry, government, consumers, innovators and others to shape their combined experience and expertise into standards-based solutions.

The knowledge embodied in our standards has been carefully assembled in a dependable format and refined through our open consultation process. Organizations of all sizes and across all sectors choose standards to help them achieve their goals.

Information on standards

We can provide you with the knowledge that your organization needs to succeed. Find out more about British Standards by visiting our website at bsigroup.com/standards or contacting our Customer Services team or Knowledge Centre.

Buying standards

You can buy and download PDF versions of BSI publications, including British and adopted European and international standards, through our website at bsigroup.com/shop, where hard copies can also be purchased.

If you need international and foreign standards from other Standards Development Organizations, hard copies can be ordered from our Customer Services team.

Subscriptions

Our range of subscription services are designed to make using standards easier for you. For further information on our subscription products go to bsigroup.com/subscriptions.

With **British Standards Online (BSOL)** you'll have instant access to over 55,000 British and adopted European and international standards from your desktop. It's available 24/7 and is refreshed daily so you'll always be up to date.

You can keep in touch with standards developments and receive substantial discounts on the purchase price of standards, both in single copy and subscription format, by becoming a **BSI Subscribing Member**.

PLUS is an updating service exclusive to BSI Subscribing Members. You will automatically receive the latest hard copy of your standards when they're revised or replaced.

To find out more about becoming a BSI Subscribing Member and the benefits of membership, please visit bsigroup.com/membership.

With a **Multi-User Network Licence (MUNL)** you are able to host standards publications on your intranet. Licences can cover as few or as many users as you wish. With updates supplied as soon as they're available, you can be sure your documentation is current. For further information, email bsmusales@bsigroup.com.

Revisions

Our British Standards and other publications are updated by amendment or revision.

We continually improve the quality of our products and services to benefit your business. If you find an inaccuracy or ambiguity within a British Standard or other BSI publication please inform the Knowledge Centre.

Copyright

All the data, software and documentation set out in all British Standards and other BSI publications are the property of and copyrighted by BSI, or some person or entity that owns copyright in the information used (such as the international standardization bodies) and has formally licensed such information to BSI for commercial publication and use. Except as permitted under the Copyright, Designs and Patents Act 1988 no extract may be reproduced, stored in a retrieval system or transmitted in any form or by any means – electronic, photocopying, recording or otherwise – without prior written permission from BSI. Details and advice can be obtained from the Copyright & Licensing Department.

Useful Contacts:

Customer Services

Tel: +44 845 086 9001

Email (orders): orders@bsigroup.com

Email (enquiries): cservices@bsigroup.com

Subscriptions

Tel: +44 845 086 9001

Email: subscriptions@bsigroup.com

Knowledge Centre

Tel: +44 20 8996 7004

Email: knowledgecentre@bsigroup.com

Copyright & Licensing

Tel: +44 20 8996 7070

Email: copyright@bsigroup.com

BSI Group Headquarters

389 Chiswick High Road London W4 4AL UK